

SHOP MANUAL

KUBOTA

Models

L185-L235-L245-L275-L285-L295-L305-L345-L355

INDEX (By Starting Paragraph)

	L185	L235	L245	L275	L285	L295	L305	L345	L355
BRAKES									
Adjustment	105	105	105	105	105	105	105	105	105
R&R and Overhaul	106	106	106	106	107	106	106	106	106
CLUTCH									
Adjustment	63	63	63	63	63	63	63	63	63
Overhaul	65	65	65	65	65	65	66	66	65
Remove and Reinstall	64	64	64	64	64	64	64	64	64
COOLING SYSTEM									
Fan Shaft	59
Radiator	56	56	56	56	56	56	56	56	56
Thermostat	57	57	57	57	57	57	57	57
Water Pump	58	58	58	58	58	58	58	58
DIESEL FUEL SYSTEM									
Fuel Filter	44	44	44	44	44	44	44	44	44
Glow Plugs	54	54	54	54	54	54	54	54	54
Injection Nozzles	50	50	50	50	50	50	50	50	50
Injection Pump	46	46	46	46	46	46	46	46	46
DIFFERENTIAL AND BEVEL GEARS									
Differential Lock	97	97	97	97	97	97	97	97	97
Overhaul	92	92	92	92	92	93	93	93	93
Remove and Reinstall	91	91	91	91	91	91	91	91	91
ELECTRICAL SYSTEM									
Alternator and Regulator	60	60	60	60	60	60	60	60	60
Starter Motor and Magnetic switch	62	62	62	62	62	62	62	62	62
Wiring Diagrams	Pages 61 through 64								
ENGINE AND COMPONENTS									
Cam Followers	29	29	29	29	29	29	29	29	29
Camshaft	33	33	33	33	33	33	33	33	33
Compression Release	24	24	24	24	24	24	24	24	24
Connecting Rods and Bearings	38	38	38	38	38	38	38	38	38
Crankshaft and Main Bearings	39	39	39	39	39	39	39	39	39
Crankshaft Rear Oil Seal	40	40	40	40	40	40	40	40	40
Cylinder Head	23	23	23	23	23	23	23	23	23
Cylinder Sleeves	37	37	37	37	37	37	37	37	37
Flywheel	41	41	41	41	41	41	41	41	41
Oil Pump	42	42	42	42	42	42	42	42	42
Piston and Rings	35	35	35	35	35	35	35	35	35

INDEX (CONT.)

	L185	L235	L245	L275	L285	L295	L305	L345	L355
ENGINE AND COMPONENTS (CONT.)									
Piston Pins	36	36	36	36	36	36	36	36	36
Remove and Reinstall engine	22	22	22	22	22	22	22	22	22
Rod and Piston Units	34	34	34	34	34	34	34	34	34
Timing Gear Cover	31	31	31	31	31	31	31	31	31
Timing Gears	32	32	32	32	32	32	32	32	32
Valve Guides	26	26	26	26	26	26	26	26	26
Valve Levers	28	28	28	28	28	28	28	28	28
Valves and Seats	25	25	25	25	25	25	25	25	25
Valve Springs	27	27	27	27	27	27	27	27	27
Valve Timing	30	30	30	30	30	30	30	30	30
FINAL DRIVE									
Overhaul	101	103	101	103	102	104	104	104	104
Remove and Reinstall	100	100	100	100	100	100	100	100	100
FRONT SYSTEM (Except FWD)									
Axle	1	1	1	1	1	1	1	1	...
Steering Spindle and Wheel Hub	3	3	3	3	3	3	3	3	...
Tie Rods and Toe-In	2	2	2	2	2	2	2	2	...
FRONT-WHEEL DRIVE									
Differential and Bevel Gear Assembly	8	8	8	8	...	8	8	8	8
Drive Shaft	9	9	9	9	...	9	9	9	9
Front Axle	6	6	6	6	...	6	6	6	6
Outer Drive Assembly	7	7	7	7	...	7	7	7	7
Tie Rods and Toe-In	5	5	5	5	...	5	5	5	5
Transfer Case	10	10	10	10	...	10	10	10	10
HYDRAULIC SYSTEM									
Fluid and Filter	114	114	114	114	114	114	114	114	114
Hydraulic Valves	121	121	121	121	121	121	121	121	121
Pump	119	119	119	119	119	119	120	120	120
Rockshaft Housing	127	127	127	127	127	127	127	127	127
Test and Adjust	116	116	116	116	116	116	116	116	116
Troubleshooting	115	115	115	115	115	115	115	115	115
POWER TAKE-OFF									
Overrunning Clutch	109	111	109	111	109	109
Remove and Reinstall	108	110	108	110	108	108	112	112	113
SHUTTLE TRANSMISSION									
Shuttle Clutches	90
Shuttle Control Valve	88
STEERING SYSTEM									
Manual Steering	11	11	11	11	11	11
Power Steering	13	...	13	13	13	13
Steering Pump	18	...	18	18	18	18
TRANSMISSION									
Front Transmission	70	81	70	81	70	70	70	70	83
Rear Transmission	74	85	74	85	74	74	74	74	85
Shifter Rails and Forks	68	79	68	79	68	68	69	69	80

DUAL DIMENSIONS

This service manual provides specifications in both the U.S. Customary and Metric (SI) systems of measurement. The first specification is given in the measuring system perceived by us to be the preferred system when servicing a particular component, while the second specification (given in parenthesis) is the converted measurement. For instance, a specification of "0.28 mm (0.011 inch)" would indicate that we feel the preferred measurement, in this instance, is the metric system of measurement and the U.S. system equivalent of 0.28 mm is 0.011 inch.

CONDENSED SERVICE DATA

	L185	L235	L245	L275	L285
GENERAL					
Engine Make	Own				
Engine Model	Z751A	D1102A	D1101A	D1302A	V1501A
Number of Cylinders	2	3	3	3	4
Bore	76 mm (3 in.)	76 mm (3 in.)	76 mm (3 in.)	82 mm (3.23 in.)	76 mm (3 in.)
Stroke	82 mm (3.23 in.)				
Displacement	743 cc (45.3 cu.in.)	1115 cc (68.3 cu.in.)	1115 cc (68.3 cu.in.)	1299 cc (79.3 cu.in.)	1487 cc (90.7 cu.in.)
Cylinder Sleeves	Dry				
Battery-Volts	12				
Ground Polarity	Negative				
Forward Speeds	8				
TUNE-UP					
Compression Pressure	3235 kPa (470 psi)				
Firing Order	1-2	1-2-3	1-2-3	1-2-3	1-3-4-2
Valve Clearance— Intake and Exhaust	0.18-0.22 mm (0.007-0.009 in.)				
Injection Timing (BTDC)	25°				
Timing Mark Location	Flywheel				
Injection Pressure	13720-14700 kPa (1990-2135 psi)				
Low Idle Speed (rpm)	800-850				
High Idle Speed (rpm)	2950	2750	2950	2750	2550
Rated Speed (rpm)	2800	2600	2800	2600	2400
Rated Power at Pto Shaft	11.5 kW (15.45 HP)	14.6 kW (19.59 HP)	16.4 kW (22 HP)	17.5 kW (23.42 HP)	19.8 kW (26.45 HP)
SIZES-CLEARANCES					
Crankshaft Main Journal— Diameter	51.921-51.940 mm (2.0441-2.0449 in.)				
Bearing Clearance— Front Bearing	0.040-0.118 mm (0.0016-0.0046 in.)				
All Other Bearings	0.040-0.104 mm (0.0016-0.0041 in.)				
Crankshaft Crankpin Journal— Diameter	43.959-43.975 mm (1.7307-1.7313 in.)				
Bearing Clearance	0.035-0.093 mm (0.0014-0.0037 in.)				
Crankshaft End Play	0.15-0.31 mm (0.006-0.012 in.)				
Camshaft Journal— Diameter	39.934-39.950 mm (1.5722-1.5728 in.)				
Bearing Clearance	0.050-0.091 mm (0.0020-0.0036 in.)				

CONDENSED SERVICE DATA (CONT.)

SIZES-CLEARANCES (CONT.)	L185	L235	L245	L275	L285
Cam Height - Intake and Exhaust			33.36 mm (1.3134 in.)		
Piston Pin - Diameter			23.002-23.011 mm (0.9056-0.9059 in.)		
Clearance in Rod			0.014-0.038 mm (0.0006-0.0015 in.)		
Valve Seat Angle - Intake and Exhaust			45°		
CAPACITIES					
Crankcase Oil	3.8 L (4.0 qts.)	6.1 L (6.4 qts.)	6.1 L (6.4 qts.)	6.1 L (6.4 qts.)	8.9 L (9.4 qts.)
Cooling System	5.3 L (5.6 qts.)	6.6 L (7.0 qts.)	6.6 L (7.0 qts.)	6.6 L (7.0 qts.)	7.0 L (7.4 qts.)
Transmission -					
2WD	22 L (23 qts.)	24 L (25 qts.)	22 L (23 qts.)	24 L (25 qts.)	27 L (29 qts.)
4WD	23 L (24 qts.)	24 L (25 qts.)	23 L (24 qts.)	24 L (25 qts.)	...
Fluid Type	Kubota UDT Transmission Fluid				
Front Axle Differential Case (4WD)	1.1 L (1.2 qts.)	2.3 L (2.4 qts.)	1.1 L (1.2 qts.)	2.6 L (2.7 qts.)	...
Fluid Type	SAE 80 or 90 Gear Oil				
Front Axle Outer Drive Case (4WD) - Each	0.8 L (0.8 qts.)	0.3 L (0.3 qts.)	0.8 L (0.8 qts.)	0.3 L (0.3 qts.)	...
Fluid Type	SAE 80 or 90 Gear Oil				
Steering Gear Box (Manual)			0.3 L (0.3 qts.)		...
Fluid Type	SAE 80 or 90 Gear Oil				

CONDENSED SERVICE DATA

GENERAL	L295	L305	L345	L355
Engine Make			Own	
Engine Model	D1301A	D1301A	V1501A	V1702A
Number of Cylinders	3	3	4	4
Bore	82 mm (3.23 in.)	82 mm (3.23 in.)	76 mm (3 in.)	82 mm (3.23 in.)
Stroke			82 mm (3.23 in.)	
Displacement	1299 cc (79.3 cu.in.)	1299 cc (79.3 cu.in.)	1487 cc (90.7 cu.in.)	1732 cc (105.6 cu.in.)
Cylinder Sleeves			Dry	
Battery-Volts			12	
Ground Polarity			Negative	
Forward Speeds			8	
TUNE-UP				
Compression Pressure			3235 kPa (470 psi)	
Firing Order	1-2-3	1-2-3	1-3-4-2	1-3-4-2
Valve Clearance - Intake and Exhaust			0.18-0.22 mm (0.007-0.009 in.)	
Injection Timing (BTDC)			25°	
Timing Mark Location			Flywheel	
Injection Pressure			13720-14700 kPa (1990-2135 psi)	

CONDENSED SERVICE DATA (CONT.)

	L295	L305	L345	L355
TUNE-UP (CONT.)				
Low Idle Speed (rpm)	800-850			
High Idle Speed (rpm)	2950	2950	2950	2750
Rated Speed (rpm)	2800	2800	2800	2600
Rated Power at Pto Shaft	19.7 kW (26.46 HP)	19.5 kW (26.21 HP)	21.9 kW (29.35 HP)	21.6 kW (29 HP)
SIZES-CLEARANCES				
Crankshaft Main Journal - Diameter	51.921-51.940 mm (2.0441-2.0449 in.)			
Bearing Clearance - Front Bearing	0.040-0.118 mm (0.0016-0.0046 in.)			
All Other Bearings	0.040-0.104 mm (0.0016-0.0041 in.)			
Crankshaft Crankpin Journal - Diameter	43.959-43.975 mm (1.7307-1.7313 in.)			
Bearing Clearance	0.035-0.095 mm (0.0014-0.0037 in.)			
Crankshaft End Play	0.15-0.31 mm (0.006-0.012 in.)			
Camshaft Journal - Diameter	39.934-39.950 mm (1.5722-1.5728 in.)			
Bearing Clearance	0.050-0.091 mm (0.002-0.0036 in.)			
Cam Height - Intake and Exhaust	33.36 mm (1.3134 in.)			
Piston Pin - Diameter	23.002-23.011 mm (0.9056-0.9059 in.)			
Clearance in Rod	0.014-0.038 mm (0.0006-0.0015 in.)			
Valve Seat Angle - Intake and Exhaust	45°			
CAPACITIES				
Crankcase Oil	6.1 L (6.4 qts.)	6.1 L (6.4 qts.)	9.1 L (9.6 qts.)	9.1 L (9.6 qts.)
Cooling System	5.8 L (6.1 qts.)	5.8 L (6.1 qts.)	7.0 L (7.4 qts.)	7.0 L (7.4 qts.)
Transmission - 2WD	26 L (27.5 qts.)	22 L (23.2 qts.)	22 L (23.2 qts.)	...
4WD	27 L (28.5 qts.)	22 L (23.2 qts.)	22 L (23.2 qts.)	32 L (33.8 qts.)
Fluid Type	Kubota UDT Transmission Fluid			
Front Axle Differential Case (4WD)	2.0 L (2.1 qts.)	5.0 L (5.3 qts.)	5.0 L (5.3 qts.)	5.0 L (5.3 qts.)
Fluid Type	SAE 80 or 90 Gear Oil			
Front Axle Outer Drive	1.5 L (1.6 qts.)	0.7 L (0.7 qts.)	0.7 L (0.7 qts.)	0.7 L (0.7 qts.)
Fluid Type	SAE 80 or 90 Gear Oil			
Steering Gear Box (Manual)	0.3 L (0.3 qts.)	...	0.2 L (0.2 qts.)	...
Fluid Type	SAE 80 or 90 Gear Oil	...	SAE 80 or 90 Gear Oil	...
Power Steering Reservoir	*	1.5 L (1.6 qts.)	1.5 L (1.6 qts.)
Fluid Type	Kubota UDT Transmission Fluid			
*Same as transmission.				

FRONT SYSTEM (TWO-WHEEL DRIVE)

FRONT AXLE

All Models So Equipped

1. Fig. 1 shows an exploded view of typical tread front axle assembly used on Models L185 and L235. Model L275 uses an adjustable tread front axle as shown in Fig. 2. All other models are equipped with an adjustable tread front axle as shown in Fig. 3.

Service procedures are basically similar for all models. Front axle pivot pin (3) is retained by a spring pin (9) at rear and by an adjusting nut (1) at front.

Diametral clearance between pivot pin and bushings (4) should not exceed 0.5 mm (0.020 inch). Renew bushings and pivot pin as needed if clearance is excessive.

When reinstalling front axle assembly, lubricate pivot pin and bushings with multi-purpose grease, then check and adjust axle end play as follows: Use a spring scale to measure force required to pivot axle as shown in Fig. 3A. Turn pivot pin adjusting nut as required to obtain pivot force between 49-117 N (11-26 pounds). Secure nut with cotter pin.

TIE RODS AND TOE-IN

All Models So Equipped

2. Tie rod and drag link ends are non-adjustable, automotive type. Renew ends that are excessively worn.

Adjust front wheel toe-in to 2-8 mm ($\frac{1}{8}$ - $\frac{5}{16}$ inch) by shortening or lengthening tie rod. Adjust length of drag link, if necessary, to permit equal turning radius in either direction.

STEERING SPINDLE AND WHEEL HUB

All Models So Equipped

3. Refer to appropriate Fig. 4 or Fig. 5 for exploded view of steering spindle and associated parts. To remove spindle (11), remove front wheel and steering arm, then lower spindle from axle. Use a suitable puller to remove wheel hub and bearings.

Inspect all parts for excessive wear, corrosion or other damage. Maximum recommended diametral clearance between spindle and bushings is 0.4 mm (0.016 inch).

Fig. 1—Exploded view of fixed tread front axle used on Models L185 and L235.

1. Adjusting nut
2. Adjusting collar
3. Pivot pin
4. Pivot bushings
5. Spindle bushings
6. Axle
7. "O" ring
8. Washer
9. Spring pin
10. Axle bracket

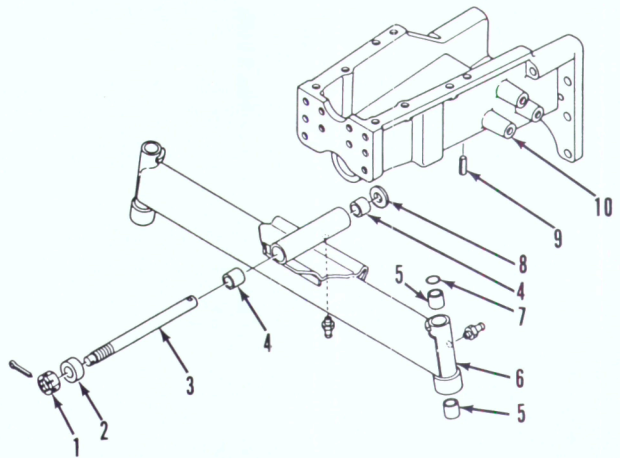

Fig. 2—Exploded view of adjustable tread front axle used on Model L275. Except for axle extension (11), refer to Fig. 1 legend.

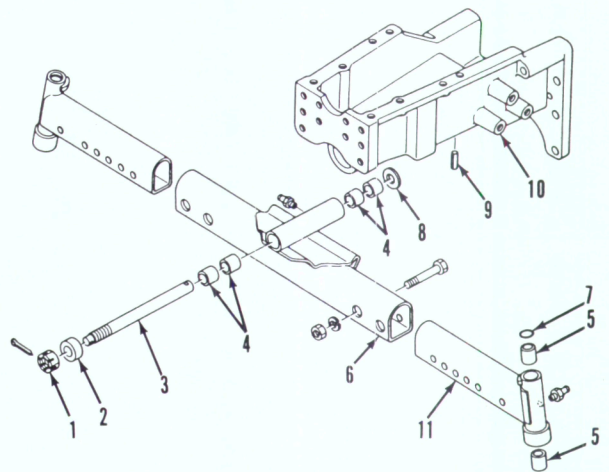
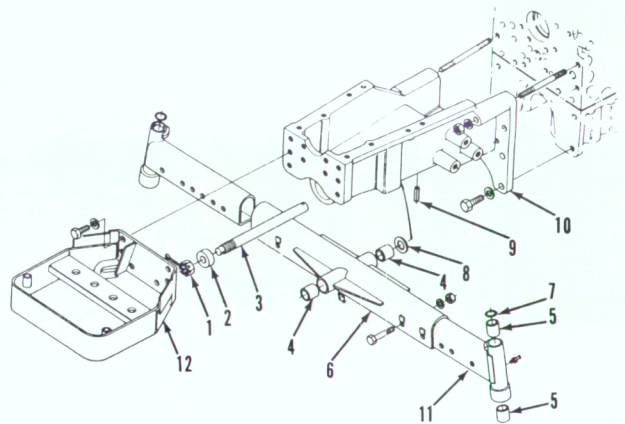

Fig. 3—Exploded view of adjustable tread front axle used on Models L245, L285, L295, L305 and L345.

1. Adjusting nut
2. Adjusting collar
3. Pivot pin
4. Pivot bushings
5. Spindle bushings
6. Axle
7. "O" ring
8. Washer
9. Spring pin
10. Axle bracket
11. Axle extension
12. Bumper



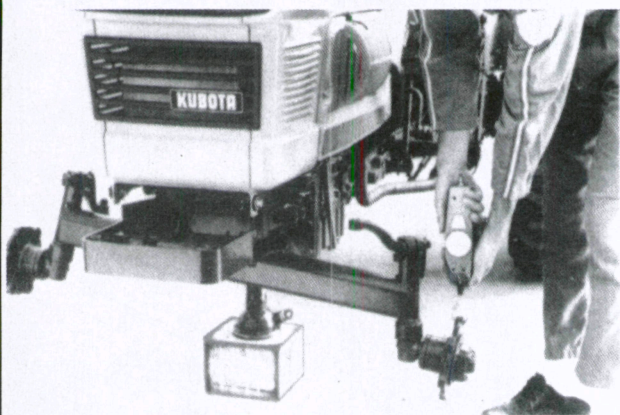

Fig. 3A—Use a spring scale to measure force required to pivot axle.

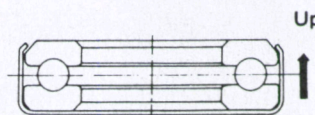

Fig. 6—Position spindle thrust bearing as shown when reinstalling spindle assembly.

To reassemble, pack wheel bearings and hub with multi-purpose grease and press bearings and hub onto spindle shaft. Tighten slotted nut securely and install cotter pin. Lubricate spindle and bushings with multi-purpose grease. Reinstall spindle assembly making certain thrust bearing is positioned correctly as shown in Fig. 6. Push upward on spindle assembly to remove end play, then install steering arm and tighten clamp bolt.

FRONT-WHEEL DRIVE

All Models So Equipped

4. Front-wheel drive assembly includes transfer case, drive shaft, front axle, differential, axle shafts and axle hub assemblies. The transfer case is mounted to bottom of range transmission housing. Transmission oil lubricates transfer case assembly. Refer to Fig. 7 for cross-sectional view of front-wheel drive axle assembly.

TIE RODS AND TOE-IN

All Models So Equipped

5. Tie rod ends are non-adjustable type. Tie rod ends that are excessively worn should be renewed.

Toe-in on all models should be 2-8 mm (1/8-5/16 inch). Adjust by lengthening or shortening tie rod.

FRONT DRIVE AXLE

All Models So Equipped

6. REMOVE AND REINSTALL.

To remove front axle assembly, proceed as follows: Remove drag link end from steering arm and disconnect drive shaft. Support front of tractor behind front axle. Support axle with a suitable floor jack and remove front wheels. Remove axle front pivot pin, then carefully lower and move axle forward to remove from axle support bracket.

Check clearance between pivot pin (1 - Fig. 8) and bushing (5) and between differential housing (6) and rear bushing

Fig. 4—Exploded view of typical spindle, wheel hub and steering linkage used on Models L185 and L235.

1. Steering arm R.H.
2. Tie rod
4. Drag link end
5. Drag link
6. Tie rod end
7. Steering arm L.H.
8. Axle
9. Thrust bearing
10. Seal
11. Spindle
12. Dust cover
13. Seal
14. Bearing (inner)
15. Wheel hub
16. Spacer
17. Bearing (outer)
18. Washer
19. Nut
20. Cap

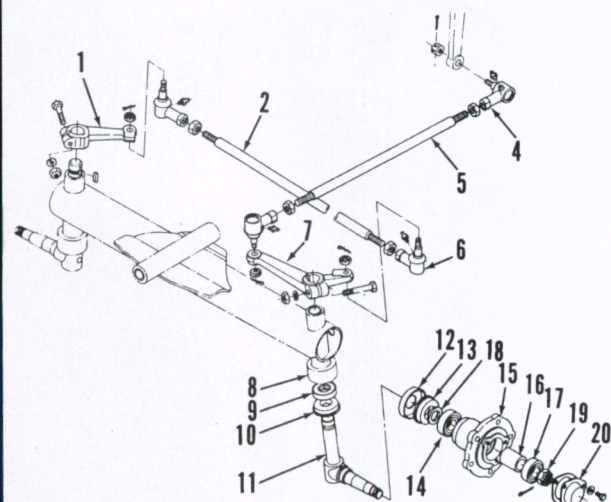
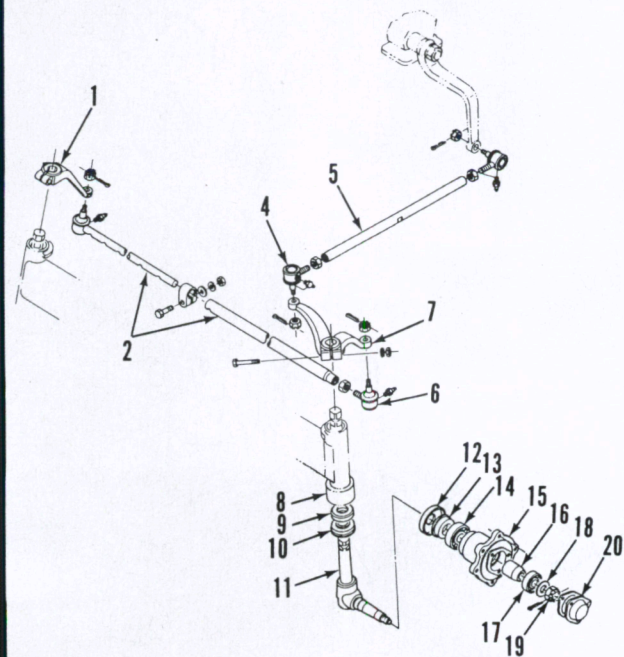

Fig. 5—Exploded view of spindle, wheel hub and steering linkage used on tractors equipped with adjustable tread front axle. Refer to Fig. 4 legend.



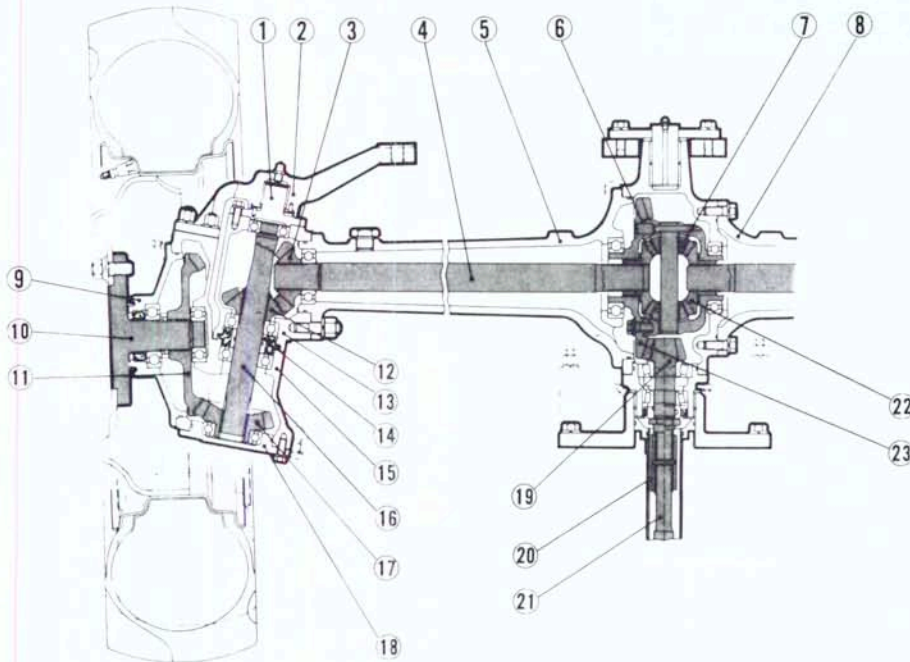

Fig. 7—Cross-sectional view of front-wheel drive axle assembly.

- | | | |
|----------------------------|------------------------|----------------------------|
| 1. Knuckle pin | 8. Axle housing R.H. | 16. Bevel gear shaft |
| 2. Steering arm | 9. Axle flange | 17. Bevel gear |
| 3. Bevel gear | 10. Axle shaft | 18. Bearing case |
| 4. Differential yoke shaft | 11. Bevel gear | 19. Bevel pinion shaft |
| 5. Axle housing L.H. | 12. Bevel gear | 20. Coupling |
| 6. Differential case | 13. Bevel gear housing | 21. Drive shaft |
| 7. Pinion gears | 14. Seal | 22. Differential side gear |
| | 15. Axle case | 23. Ring gear |

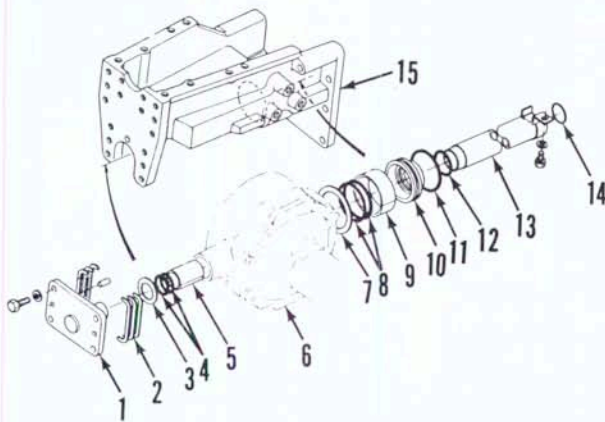

Fig. 8—Exploded view of front axle support and components for tractors equipped with front-wheel drive. "O" rings (4,11 and 12) are not used on some models and front bushing (5) is a two piece assembly on some models.

1. Pivot pin & bracket
2. Shims
3. Thrust washer
4. "O" rings
5. Bushing
6. Differential housing
7. Thrust washer
8. "O" rings
9. Bushing
10. Seal cover
11. "O" ring
12. "O" ring
13. Cover
14. "O" ring
15. Axle mounting bracket

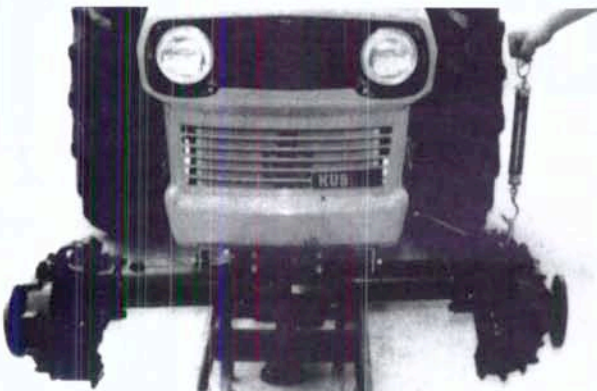

Fig. 9—Use a spring scale to check force required to pivot front axle. Refer to text.

(9). If clearance exceeds 0.4 mm (0.016 inch), renew components as needed. Renew all "O" rings.

Reinstall axle assembly by reversing disassembly procedure using original pivot pin shim pack (2). Apply grease to front and rear pivot bushings. Use a spring scale to measure force required to pivot axle from lowest position to highest position as shown in Fig. 9. Add or remove pivot pin shims as necessary to obtain recommended pivot force of 49-117N (11-26 pounds). Recommended lubricant for front axle and differential case is SAE 90 gear oil.

OUTER DRIVE ASSEMBLY

All Models So Equipped

7. R&R AND OVERHAUL. To remove outer drive assembly, first raise and support front of tractor. Remove front wheel, then disconnect drag link (left side) and tie rod. Support drive housing, remove cap screws mounting housing to axle housing and withdraw drive housing assembly from axle. Retain shims (3—Fig. 10) for use in reassembly. Pull differential yoke shaft (4) with bevel gear (7) and bearing (6) from axle housing.

To disassemble, remove axle flange (33) with bevel gear (26) and axle (34) and allow oil to drain into a suitable container. Remove inner bearing (25) and bevel gear from axle shaft. Remove retaining rings (27 and 28) and thrust washer (29), then press axle out of bearing (30) and flange. Drive oil seal (31) out of flange.

Remove knuckle support (right side) or steering arm (left side), then remove knuckle pin (10—Fig. 11). Retain shims (4) for use in reassembly. Remove lower bearing cap (22—Fig. 10), bearing (21) and bevel gear (23). Keep shims (20) together for use in reassembly. Tap bevel gear shaft (13) upward and remove upper bearing (8) and split collar (9), then tap shaft downward and separate bevel gear housing (10) from axle case (24). Remove bearings and oil seal (17) from bevel gear shaft.

Examine gears for chipped, cracked or missing teeth. Inspect bearings for roughness, corrosion or other damage. Check diametral clearance of knuckle pin (10—Fig. 11) in bushing (8). If clearance exceeds 0.4 mm (0.016 inch), renew parts as needed. Renew all "O" rings and oil seals. Lubricate parts with clean oil prior to reassembly.

To reassemble, reverse the disassembly procedure. Renew all gaskets. "O" rings and seals during reassembly. Lubricate lip of oil seals with grease during reassembly. Backlash between upper bevel gear

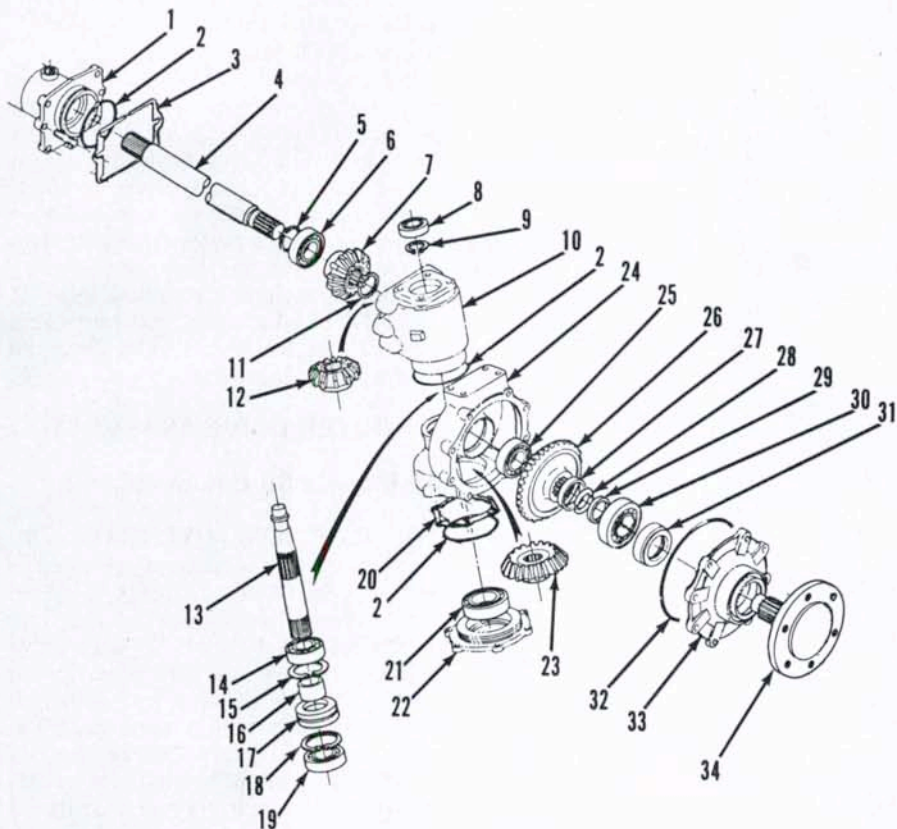

Fig. 10—Exploded view of outer drive assembly used on tractors equipped with front-wheel drive. Some models have a spacer between bearing (6) and bevel gear (7) and retain gear with a cap screw and washer instead of snap rings (5 and 11).

- | | | | |
|----------------------------|------------------------|-----------------|--------------------|
| 1. Axle housing | 10. Bevel gear housing | 18. Snap ring | 26. Bevel gear |
| 2. "O" ring | 11. Snap ring | 19. Bearing | 27. Retainer |
| 3. Shim | 12. Bevel gear | 20. Shim | 28. Retaining ring |
| 4. Differential yoke shaft | 13. Bevel gear shaft | 21. Bearing cap | 29. Thrust washer |
| 5. Snap ring | 14. Bearing | 22. Bearing cap | 30. Bearing |
| 6. Bearing | 15. Snap ring | 23. Bevel gear | 31. Oil seal |
| 7. Bevel gear | 16. Sleeve | 24. Axle case | 32. "O" ring |
| 8. Bearing | 17. Oil seal | 25. Bearing | 33. Flange |
| 9. Split ring | | | 34. Axle shaft |

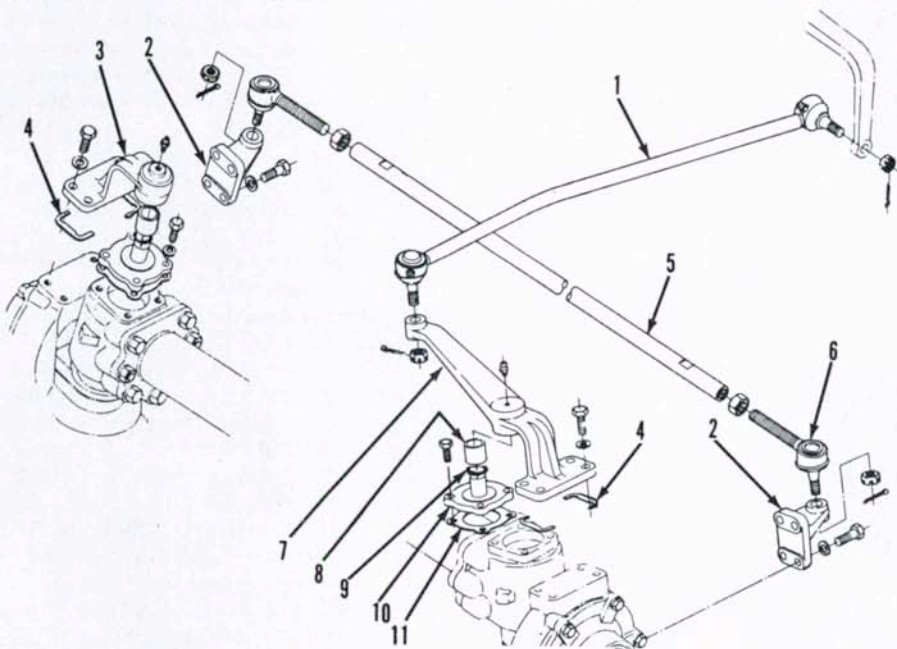

Fig. 11—View of front-wheel drive steering linkage and knuckle pins.

- | | | | |
|-------------------------|----------------|-----------------|-----------------|
| 1. Drag link | 4. Shim | 7. Steering arm | 10. Knuckle pin |
| 2. Arms | 5. Tie rod | 8. Bushing | 11. Gasket |
| 3. Knuckle support R.H. | 6. Tie rod end | 9. "O" ring | |

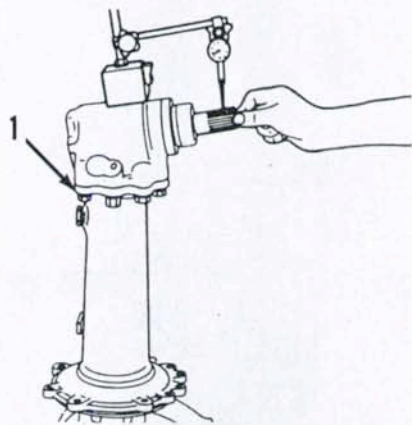

Fig. 12—Use a dial indicator to check backlash between upper bevel gear and yoke shaft bevel gear. Add or remove shims (1) between housings to obtain desired backlash.

(12—Fig. 10) and differential yoke shaft gear (7) should be 0.15-0.30 mm (0.006-0.012 inch). Use a dial indicator to check backlash as shown in Fig. 12, then add or remove shims (1) between bevel gear housing and axle housing to obtain desired backlash. Recommended backlash between lower bevel gear (23—Fig. 10) and axle shaft bevel gear (26) is 0.15-0.30 mm (0.006-0.012 inch). Use a dial indicator to check backlash as shown in Fig. 13, then add or remove shims (2) at lower bearing cap to obtain desired backlash. Tighten axle flange mounting cap screws to a torque of 20-34 N·m (15-25 ft.-lbs.). Tighten bevel gear case to axle housing mounting cap screws to a torque of 98-132 N·m (75-95 ft.-lbs.). Tighten knuckle support or steering arm mounting nuts to a torque of 80-90 N·m (60-65 ft.-lbs.), then measure clearance between support and pivot pin bracket with a feeler gage as shown in Fig. 14. Adjust shim pack under knuckle support as needed to obtain desired clearance of 0.1-0.2 mm (0.004-0.008 inch). Check end play of ax-

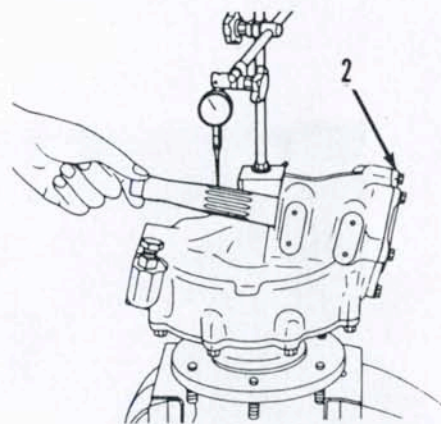

Fig. 13—Check backlash between lower bevel gear and axle bevel gear and adjust as necessary with shims (2) at lower bearing cap.

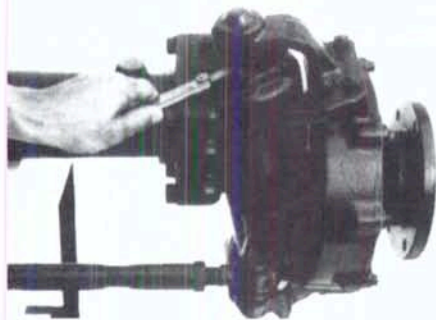

Fig. 14—Use a feeler gage to check knuckle pin to support clearance. Add or remove knuckle support mounting shims to obtain desired clearance.

le shaft using a dial indicator as shown in Fig. 15. Maximum allowable end play is 0.5 mm (0.020 inch). If end play is excessive, check condition of thrust washer (29—Fig. 10) and retainer (27). Refill unit with SAE 90 gear oil.

DIFFERENTIAL AND BEVEL GEAR ASSEMBLY

All Models So Equipped

8. R&R AND OVERHAUL. Drain oil from axle housing, then remove outer drive assemblies and differential yoke shafts as outlined in previous paragraph. Disconnect drive shaft. Support differential housing, then remove front pivot pin and separate axle housing assembly from tractor.

To remove differential assembly, remove mounting cap screws and separate left axle housing (30—Fig. 16) from differential housing (14). Remove differential assembly from housing. Remove bevel pinion case (6) mounting cap screws, then withdraw pinion assembly from differential housing. Retain shims for use in reassembly.

To disassemble differential, remove carrier bearings (16 and 27) using a



Fig. 15—Axial end play of axle shaft should not exceed 0.5 mm (0.020 inch). Use a dial indicator as shown to measure end play.

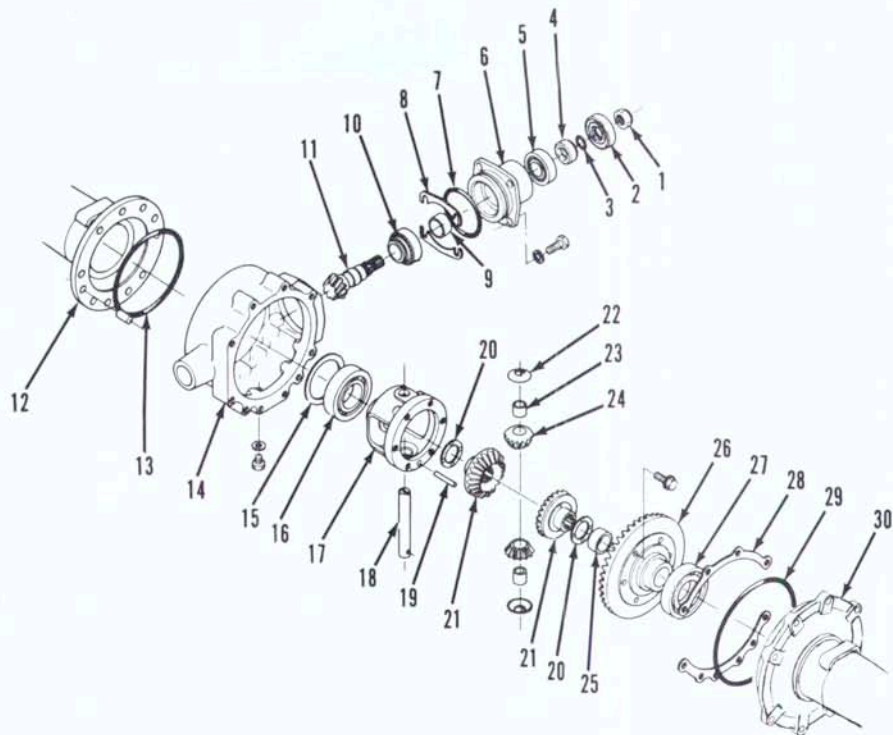

Fig. 16—Exploded view of front-wheel drive differential and bevel drive gear assembly. Spacer (9) is not used on all models.

- | | | |
|------------------|--------------------------|-----------------------|
| 1. Adjusting nut | 11. Bevel pinion shaft | 21. Side gears |
| 2. Oil seal | 12. Axle housing R.H. | 22. Thrust washer |
| 3. "O" ring | 13. "O" ring | 23. Bushing |
| 4. Sleeve | 14. Differential housing | 24. Pinion gear |
| 5. Bearing | 15. Shim | 25. Bushing |
| 6. Bearing case | 16. Carrier bearing | 26. Ring gear |
| 7. "O" ring | 17. Differential case | 27. Carrier bearing |
| 8. Shims | 18. Pinion shaft | 28. Shim |
| 9. Spacer | 19. Dowel | 29. "O" ring |
| 10. Bearing | 20. Thrust washer | 30. Axle housing L.H. |

suitable puller. Remove ring gear mounting caps screws and remove ring gear (26), side gear (21), thrust washer (20) and bushing (25). Scribe match marks on pinion gears (24) and side gear (21) so gears can be reinstalled in their original positions. Use a punch to remove pinion shaft dowel pins (19), then withdraw pinion shaft (18) and gears from differential case.

Place bevel pinion drive gear (11) in a suitable holding fixture, then remove nut (1). Press bevel gear shaft out of bearings and bearing case.

Inspect all gears and bearings for ex-

cessive wear or other damage. Maximum allowable operating clearance between differential side gears (21) and differential case (17) and ring gear bushing (25) is 0.4 mm (0.016 inch). Pinion shaft (18) to pinion gear bushing (23) clearance should not exceed 0.3 mm (0.012 inch). Renew all parts as needed. Ring gear and pinion are available only as a matched set.

Reassemble differential making certain match marks made during disassembly are aligned. Check side gear to pinion gear backlash using a dial indicator as shown in Fig. 17. Backlash should not exceed 0.4 mm (0.016 inch).

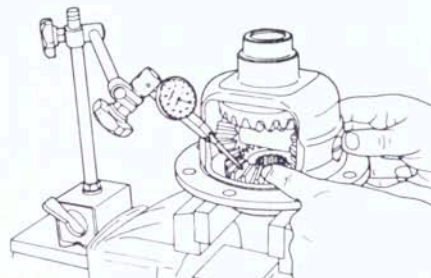

Fig. 17—Backlash between side gears and pinion gears should not exceed 0.4 mm (0.016 inch).

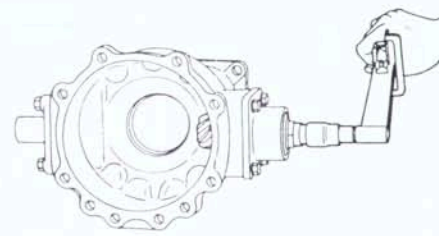

Fig. 18—Bevel pinion shaft bearing preload should be adjusted to obtain recommended rolling torque of 1.27-1.67 N·m (11-15 in.-lbs.)

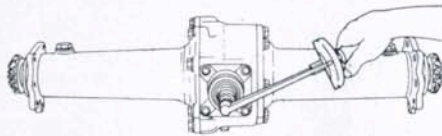

Fig. 19—Rolling torque of bevel pinion shaft with differential assembly installed should be within range of 1.96-2.94 N·m (17-26 in.-lbs.). Refer to text.

Side gear thrust washers (20—Fig. 16) are available in three different thicknesses to adjust backlash to desired value. Tighten ring gear mounting cap screws to a torque of 61-68 N·m (45-50 ft.-lbs.).

Assemble bevel pinion shaft using new bearings and oil seal. Tighten adjusting nut finger tight, then reinstall pinion shaft and case into differential housing. Use a torque wrench to measure torque required to turn pinion shaft as shown in Fig. 18. Tighten adjusting nut (1—Fig. 16) to obtain recommended rolling torque of 1.27-1.67 N·m (11-15 in.-lbs.). Stake adjusting nut after bearing adjustment is completed.

Install differential assembly and ring gear into differential case and reinstall axle housing. Measure torque required to

Fig. 22—Exploded view of two-piece drive shaft assembly with center carrier bearing used on some models.

1. Snap ring
2. Coupling
3. Front drive shaft
4. Front tube
5. Gasket
6. Rear drive shaft
7. Bearing case
8. Oil seals
9. Retaining rings
10. Bearing
11. Snap ring
12. Center tube
13. "O" ring
14. Rear tube

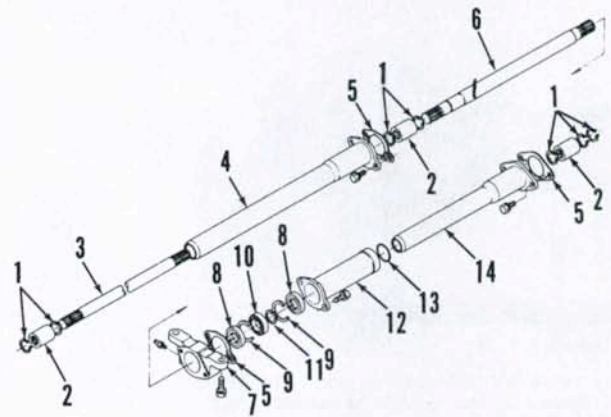

rotate bevel pinion shaft and differential as shown in Fig. 19. Rolling torque should be within the range of 1.96-2.94 N·m (17-26 in.-lbs.). Adjust as needed by changing shim thickness (15 and 8—Fig. 16) in differential case and bevel pinion case.

Check and adjust ring gear to bevel pinion backlash as follows: Secure ring gear by inserting a screwdriver through oil drain hole in housing. Set dial indicator on bevel pinion shaft spline as shown in Fig. 20, then move pinion shaft and measure backlash. Recommended

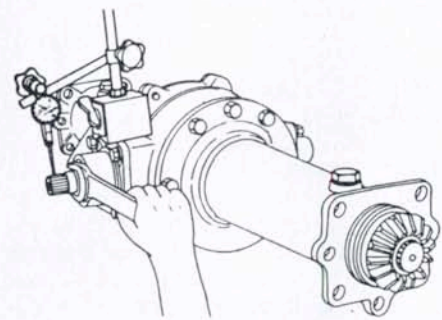

Fig. 20—Use a dial indicator to check backlash between ring gear and pinion. Recommended backlash is 0.15 mm (0.006-0.010 inch).

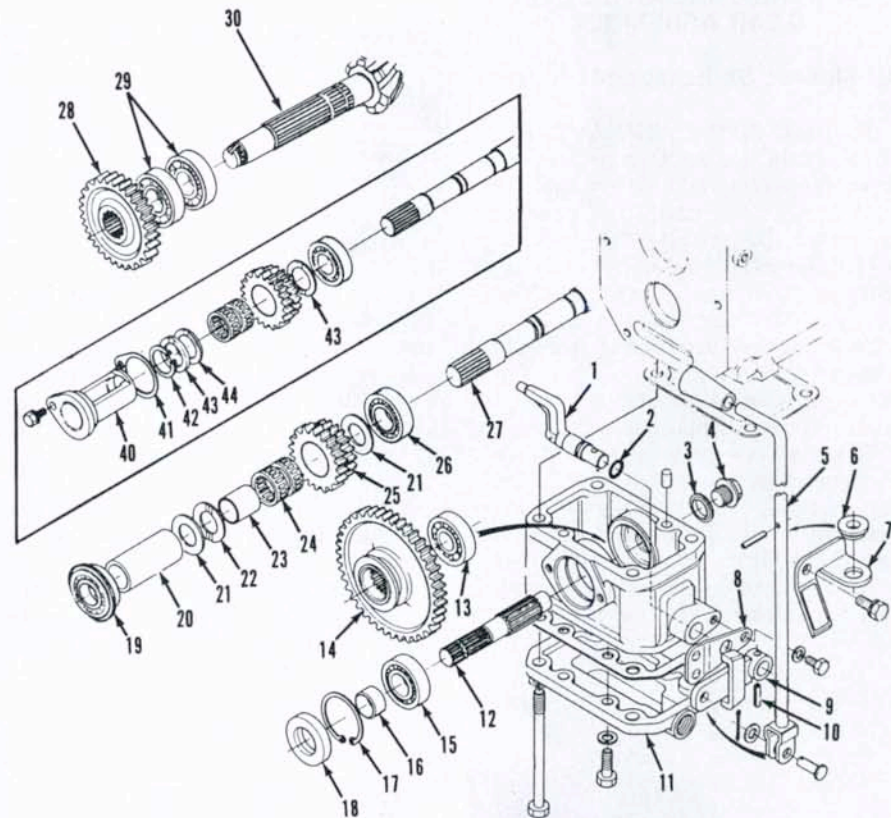

Fig. 23—Transfer case is mounted to bottom of range transmission housing and is lubricated with transmission oil. Idler gear assembly shown in inset (40 through 44) is used on Models L305, L345 and L355.

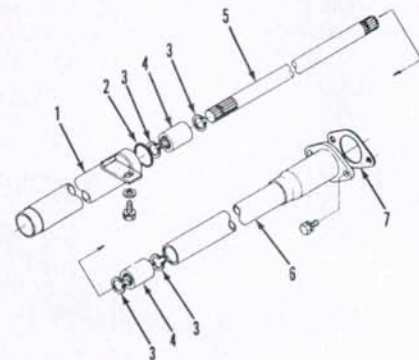

Fig. 21—Exploded view of one-piece drive shaft assembly used on some models.

1. Front tube
2. "O" ring
3. Snap ring
4. Coupling
5. Drive shaft
6. Rear cover
7. Gasket

1. Shift lever
2. "O" ring
3. Seal washer
4. Plug
5. Shift lever
6. Rubber guide
7. Support
8. Guide
9. Shift arm
10. Spring pin
11. Cover
12. Shaft
13. Bearing
14. Driven gear
15. Bearing
16. Sleeve
17. Snap ring
18. Oil seal
19. Bearing
20. Spacer
21. Washers
22. Thrust washer
23. Inner race
24. Bearings
25. Idler gear
26. Bearing
27. Pto shaft
28. Drive gear
29. Bearings
30. Bevel pinion shaft
40. Spacer
41. Shim
42. Snap ring
43. Thrust washers
44. Washer

backlash is 0.15-0.25 mm (0.006-0.010 inch). If measured backlash is excessive, decrease shims (15 - Fig. 16) on differential case side and add shims (28) of same thickness between left axle housing and differential case. If backlash is insufficient, decrease shims (28) and add same thickness to shims (15).

Complete reassembly and installation of axle assembly. Refill axle housing with SAE 90 gear oil.

DRIVE SHAFT

All Models So Equipped

9. Models L305, L345 and L355 use a two-piece drive shaft with a center carrier bearing (Fig. 22). All other models use a one-piece drive shaft as shown in Fig. 21.

Removal of drive shaft consists of removing mounting screws from drive shaft tubes, disengaging retaining rings and sliding drive shaft out of couplers. Remove center carrier bearing and oil seals on models so equipped.

Inspect shaft splines and couplers for excessive wear or other damage. Reinstall drive shaft by reversing removal procedure.

TRANSFER CASE

All Models So Equipped

10. **R&R AND OVERHAUL.** Drive gear (28 - Fig. 23) and idler gear (25) are located in range transmission housing. Refer to appropriate transmission section for service procedures.

To service transfer case, first drain oil from transmission housing. Disconnect drive shaft and shift linkage. Remove transfer case mounting cap screws and lower unit from transmission housing.

To disassemble, remove oil seal (18), retaining ring (17) and plug (4). Tap shaft (12) out front of case and remove gear (14). Drive pin (10) out of shift arm (9) and remove shift lever (1).

To reassemble, reverse the disassembly procedure. Apply liquid gasket maker to surfaces of drive case mounting gasket when reinstalling.

STEERING SYSTEM

MANUAL STEERING

All Models So Equipped

All models equipped with manual steering box use a recirculating ball nut steering gear similar to type shown in Fig. 24.

Fig. 24—Exploded view of manual steering gear assembly. Components shown in inset are used on Models L185, L245 and L285.

1. Nut
2. Nut
3. Side cover
4. Gasket
5. Shim
6. Adjusting screw
7. Sector shaft
8. Gear case
9. Bushing
10. Seal
11. Pitman arm
12. Bearings
13. Ball nut assy.
14. "O" ring
15. Column
16. Nut
17. "O" rings
18. Support bracket
19. Spring
20. Pin & rivet
21. Steering shaft
22. Bushing
23. Seal
24. Seal
25. Shim
26. Cover
27. Column
28. Support
29. Bushing

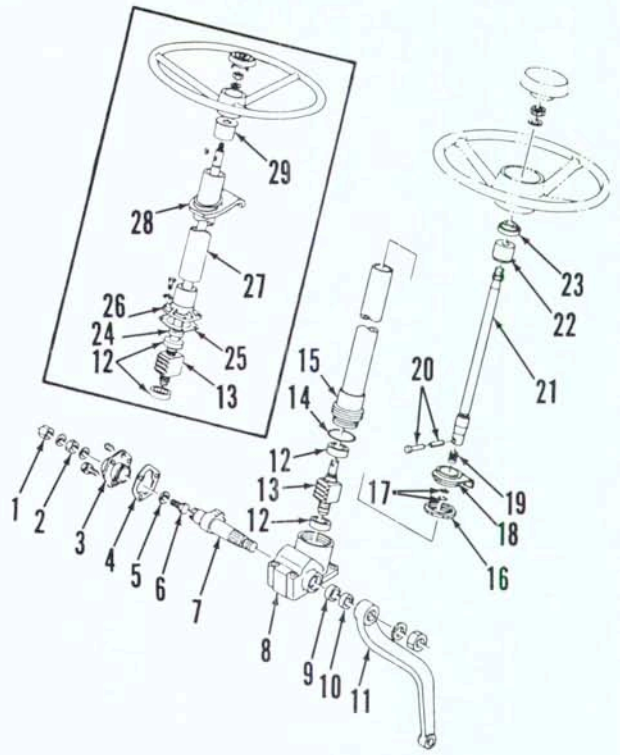

11. **ADJUSTMENT.** Steering wheel free play should be within the range of 20-50 mm (13/16-2 inches) measured at steering wheel rim. To adjust steering play, loosen locknut (2 - Fig. 24) and turn adjusting screw (6) to obtain desired free play. (Turning adjusting screw clockwise will reduce free play.) Tighten locknut to secure adjusting screw.

On Models L185, L245 and L285, steering shaft end play should be approximately 0.2 mm (0.008 inch). If end play is excessive, adjust by changing cover shim (25) thickness.

12. **R&R AND OVERHAUL.** To remove steering gear assembly, first remove steering wheel using a suitable puller. Remove instrument panel, cowl and fuel tank. Disconnect drag link from pitman arm. Remove steering gear mounting cap screws and withdraw steering gear assembly.

To disassemble, first drain oil from housing. Make sure match marks are present on pitman arm (11 - Fig. 24) and sector shaft (7), then remove pitman arm using a suitable puller. Remove side cover mounting cap screws and adjusting screw locknut. Turn adjusting screw (6) to remove side cover, then tap sector shaft out side cover opening. Remove steering column and steering shaft with ball nut assembly (13). Ball nut is available only as an assembled unit and disassembly is not recommended.

To reassemble unit, reverse the disassembly procedure while noting the following: Be sure to renew all "O" rings and oil seals. Install sector shaft into case and turn fully clockwise, then install ball nut and engage it with sector gear. Install side cover using liquid gasket on mounting surfaces of gasket. On Models L185, L245 and L285, install cover (26) with shim (25) thickness required to obtain 0.2 mm (0.008 inch) steering shaft end play. On all other models, install steering shaft assembly without upper bushing (22) and seal (23). Use a torque wrench (Fig. 25) to check torque required to turn steering shaft which should be less than 1.7 N·m (15 in.-lbs.). Turn steering column (1) into or out of sector housing to obtain desired turning torque, then tighten column locknut (2) securely. Be sure to align

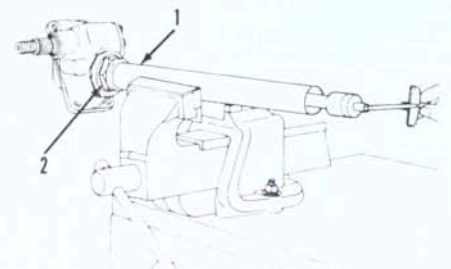

Fig. 25—Adjust steering shaft bearing preload by turning steering column (1) into or out of housing. Refer to text.

1. Steering column
2. Locknut

match marks when reinstalling pitman arm. Refill unit with approximately 0.2 L (2/5 pint) of SAE 90 gear oil.

Reinstall steering unit on tractor and adjust steering wheel free play as previously outlined.

POWER STEERING

Integral Type

13. ADJUSTMENT. Steering wheel free play should be within range of 25-50 mm (13/16 -2 inches) measured at steering wheel rim. To adjust free play, turn adjusting screw (1 - Fig. 26) clockwise to reduce free play or counter-clockwise to increase free play.

To check and adjust relief valve pressure setting, connect a 0-20000 kPa (0-3000 psi) pressure gage at test port (2 - Fig. 27) in steering valve housing. Operate steering until oil is at operating temperature. With engine running at 2600 rpm, turn and hold steering wheel fully in one direction and observe pressure reading when relief valve is actuated. Pressure should be 10000-10700 kPa (1450-1550 psi) on all models. To adjust relief valve pressure setting, turn adjuster (1) to obtain desired opening pressure.

If unable to obtain recommended pressure, check hydraulic pump output as outlined in paragraph 19. If pump output is satisfactory, remove and inspect relief valve poppet and spring (33 - Fig. 28).

14. R&R AND OVERHAUL. To remove steering gear assembly, first remove steering wheel using a suitable puller. Remove instrument panel, cowl and fuel tank. Disconnect drag link from pitman arm using a suitable puller. Disconnect hydraulic oil tubes, remove steering box mounting cap screws and withdraw steering gear assembly.

To disassemble, first place match marks on pitman arm and sector shaft. Use a suitable puller to remove pitman arm. Drain oil from housing. Remove steering column (44 - Fig. 28). Drive out rivet and spring pin (43) and remove steering shaft (45), then unbolt and remove top cover (38). Secure worm shaft (18) and remove locknut (36). Separate valve assembly and thrust bearings from housing. Remove side cover mounting cap screws, then turn adjusting screw (5) clockwise to remove side cover (2). Remove sector shaft through side cover opening. Remove retaining ring (12) and bottom cover (13). Withdraw ball nut assembly (21).

NOTE: Ball nut assembly is available only as a complete unit and disassembly is not recommended.

Fig. 26—Turn steering gear adjusting screw (1) to adjust steering wheel free play.

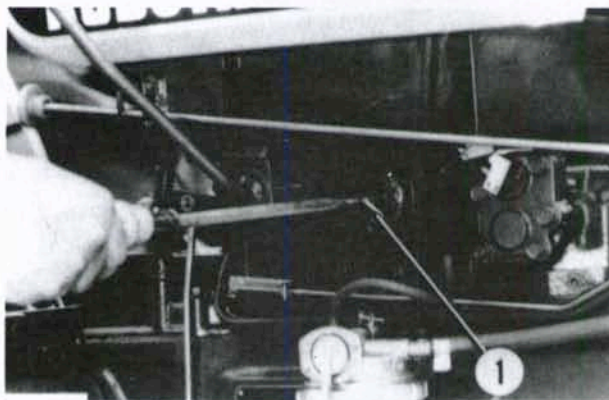

Fig. 27—To check integral type power steering pressure, attach a pressure gage at test port (2). Pressure setting can be adjusted by turning adjuster (1). Refer to text.

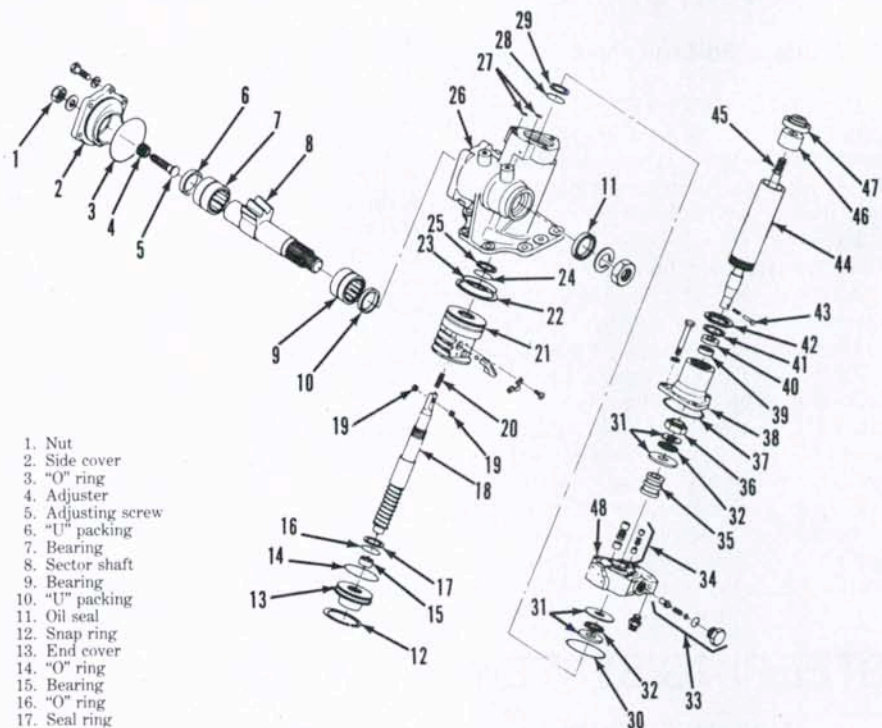
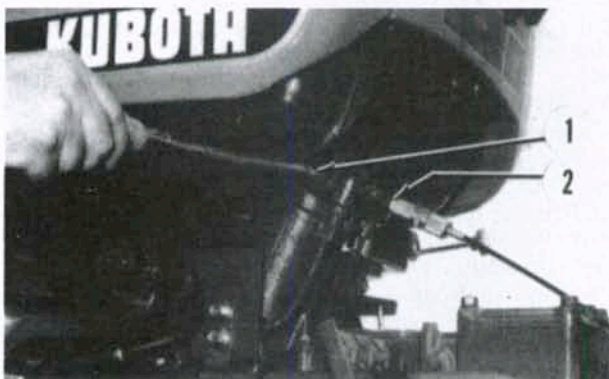

Fig. 28—Exploded view of integral type power steering used on some models.

- | | | | |
|--------------------|------------------------|-------------------------------|--------------------|
| 1. Nut | 26. Housing | 34. Reaction pistons & spring | 41. Snap ring |
| 2. Side cover | 27. "O" ring | 35. Valve spool | 42. Nut |
| 3. "O" ring | 28. "O" ring | 36. Nut | 43. Rivet & pin |
| 4. Adjuster | 29. Seal ring | 37. "O" ring | 44. Column |
| 5. Adjusting screw | 30. "O" ring | 38. Upper cover | 45. Steering shaft |
| 6. "U" packing | 31. Washers | 39. Bearing | 46. Bushing |
| 7. Bearing | 32. Thrust bearing | 40. Oil seal | 47. Seal |
| 8. Sector shaft | 33. Relief valve assy. | | 48. Valve housing |
| 9. Bearing | | | |
| 10. "U" packing | | | |
| 11. Oil seal | | | |
| 12. Snap ring | | | |
| 13. End cover | | | |
| 14. "O" ring | | | |
| 15. Bearing | | | |
| 16. "O" ring | | | |
| 17. Seal ring | | | |
| 18. Worm shaft | | | |
| 19. Seal rings | | | |
| 20. Spring | | | |
| 21. Ball nut | | | |
| 22. Seal ring | | | |
| 23. "O" ring | | | |
| 24. "O" ring | | | |
| 25. Seal ring | | | |

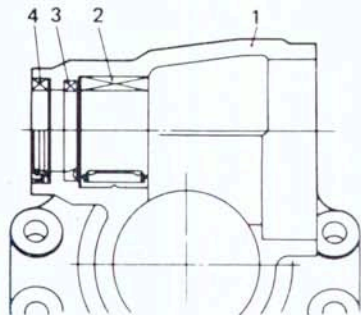

Fig. 29—Open side of sector shaft "U" packing (3) should face inward and open side of seal (4) should face outward.

- 1. Gear housing
- 2. Needle bearing
- 3. "U" packing
- 4. Seal

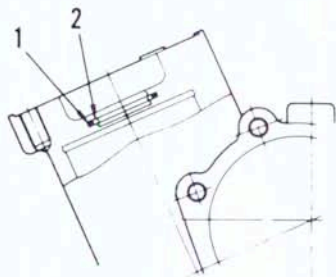

Fig. 30—Be sure "O" ring (1) is installed behind Teflon seal ring (2) when reinstalling worm shaft seals in housing.

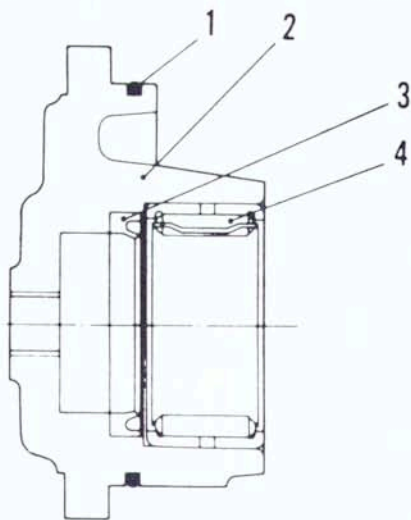

Fig. 33—Side cover seal and bearing installation. Be sure open side of "U" packing faces inward.

- 1. "O" ring
- 2. Side cover
- 3. "U" packing
- 4. Needle bearing

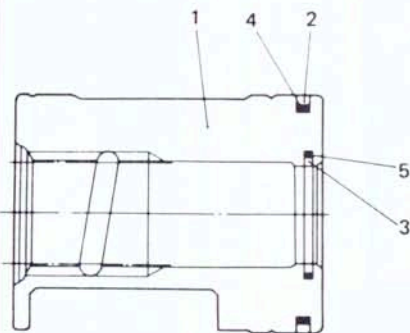

Fig. 31—View of ball nut seals correctly installed. "O" ring must be behind Teflon rings.

- 1. Ball nut assy.
- 2. Teflon seal
- 3. Teflon seal
- 4. "O" ring
- 5. "O" ring

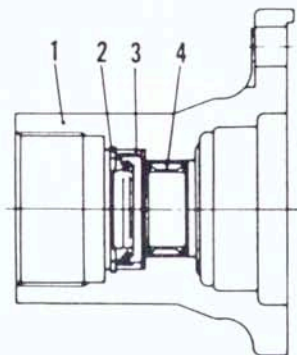

Fig. 34—Upper cover bearing and seal installation. Open side of oil seal (3) should face bearing (4).

- 1. Upper cover
- 2. Snap ring
- 3. "O" ring
- 4. Bearing

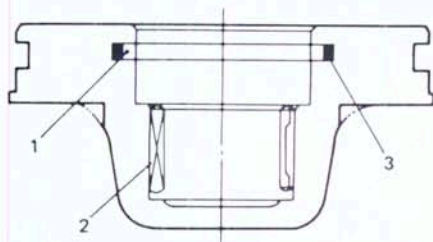
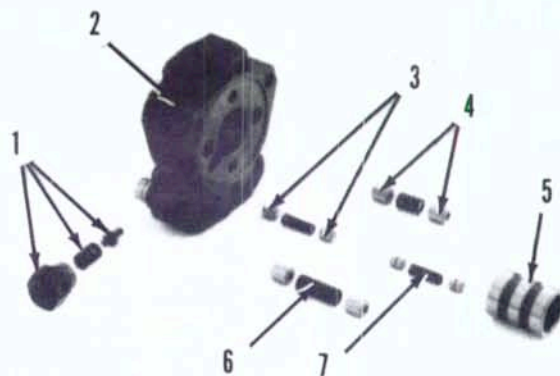

Fig. 32—View of lower cover seal ring and bearing installation.

- 1. Teflon seal
- 2. Needle bearing
- 3. "O" ring

Fig. 35—Be sure to align "P" marks on spool (5) and valve (2) when reassembling.

- 1. Relief valve assy.
- 2. Valve housing
- 3. Pistons
- 4. Pistons
- 5. Spool
- 6. Spring
- 7. Spring



Separate components of valve assembly and inspect for wear, scoring or other damage. Valve spool (35) and valve housing (48) must be renewed as a matched set. Check all components for

wear and correct fit and renew any which do not meet the following specifications: Clearance between cylinder and ball nut should be 0.030-0.079 mm (0.0012-0.0031 inch). Worm shaft axial end play in ball nut should be 0.02 mm (0.0008 inch) and maximum allowable end play is 0.12 mm (0.0047 inch). Worm shaft must rotate smoothly in ball nut. Worm shaft lower bearing journal outside diameter should be 28.562-28.575 mm (1.1245-1.1250 inches) with minimum allowable diameter of 28.475 mm (1.1211 inches). Clearance between valve housing and spool should be 0.008-0.015 mm (0.0003-0.0006 inch) and maximum allowable clearance is 0.025 mm (0.001 inch). Be sure that spool and sleeve are free of scratches, nicks or burrs and that spool slides smoothly in sleeve. Sector shaft bearing journal diameter should be 38.059-38.075 mm (1.4984-1.4990 inches). Renew shaft if diameter is less than 38.025 mm (1.4970 inches).

When renewing needle bearings, position bearings in housings so press force is applied against side of bearing with manufacturer's marks. Install new oil seals, "O" rings and Teflon seal rings as shown in Figs. 29 through 34. Lubricate seals and "O" rings prior to reassembly. Apply molybdenum disulfide "Molycoat" to steering column bushing (46—Fig. 28) and oil seal (47).

Reassemble steering unit by reversing the disassembly procedure. Be sure to align "P" marks on valve spool (5—Fig. 35) and valve housing (2). Position ball nut and worm shaft assembly, valve housing assembly and thrust bearings into steering gear housing, then install special mounting plate (1—Fig. 36) to retain components in housing. (Special plate can be fabricated using dimensions shown in Fig. 36A.) Turn worm shaft clockwise, tighten locknut hand tight and stake locknut threads with a pin punch. Install sector shaft and tighten side cover mounting cap screws to 40-55 N·m (30-40 ft.-lbs.) torque. Remove

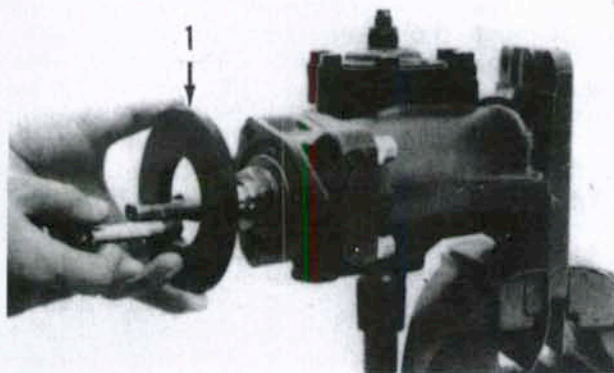

Fig. 36—Install special mounting plate (1) to retain ball nut and thrust bearings while tightening worm shaft locknut. See Fig. 36A.

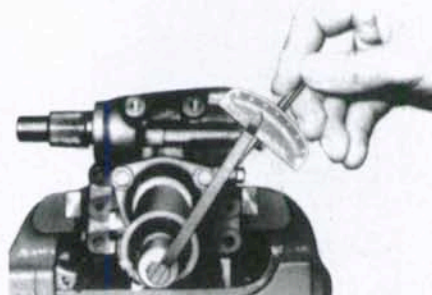

Fig. 38—As a final assembly check, measure torque required to start rotation of worm shaft. Torque should not exceed 1.7 N·m (15 in.-lbs.)

special plate and install top cover. Tighten retaining screws to a torque of 40-55 N·m (30-40 ft.-lbs.). Align match marks and install pitman arm onto sector shaft. Tighten retaining nut to a torque of 120-155 N·m (90-115 ft.-lbs.).

Check backlash between sector gear and ball nut using a dial indicator as shown in Fig. 37. Turn adjusting screw (5—Fig. 28) as required to obtain recommended backlash of 0.1-0.4 mm (0.004-0.016 inch). To check for proper final assembly of steering gear, use a torque wrench as shown in Fig. 38 to measure torque required to start rotation of worm shaft. Torque should be less than 1.7 N·m (15 in.-lbs.). If measured torque exceeds 1.8 N·m (16

in.-lbs.), correct problem before reinstalling unit on tractor. Install steering shaft and column tube and tighten nut to a torque of 98-127 N·m (75-94 ft.-lbs.).

Reinstall steering gear on tractor by reversing removal procedure. On models equipped with separate reservoir tank, refill hydraulic system with approximately 1.5 L (1.6 quarts) of Kubota UDT fluid. Adjust steering pressure relief valve setting as previously outlined.

Booster Type

15. On models equipped with booster type power steering, a manual steering gear assembly is used which is identical to steering gear outlined in paragraphs 11 and 12. The power booster unit is mounted on left side of tractor and transfers hydraulic power assist directly to steering drag link which is attached to booster unit. The booster unit consists of a hydraulic cylinder with a valve housing built into the cylinder. When steering wheel is turned, valve spool shifts and directs hydraulic fluid to one side of power cylinder which actuates cylinder and assists in turning front wheels.

16. **ADJUSTMENT.** Steering wheel free play is adjusted as outlined in paragraph 11.

To check and adjust booster relief valve pressure setting, proceed as follows: Be sure hydraulic fluid is at normal operating temperature. Remove plug from test port in bottom of valve housing and install a pressure gage as shown in Fig. 39A. Operate engine at rated speed, turn steering wheel in one direction until front wheels stop and observe pressure gage reading. When relief valve opens, pressure should be approximately 6900 kPa (1000 psi). To adjust pressure, turn relief valve adjusting screw (16—Fig. 39), located in valve housing, clockwise to increase pressure or counter-clockwise to reduce pressure.

17. **R&R AND OVERHAUL.** To remove booster unit, first disconnect hydraulic hoses and drain oil. Disconnect drag link end from booster unit. Disconnect booster unit from front mounting bracket and pitman arm and remove from tractor.

To disassemble unit, first move piston rod in and out of cylinder to drain oil. Remove retainer (1—Fig. 39) and dust

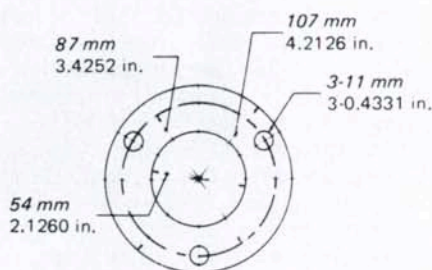

Fig. 36A—Mounting plate can be fabricated using dimensions shown.

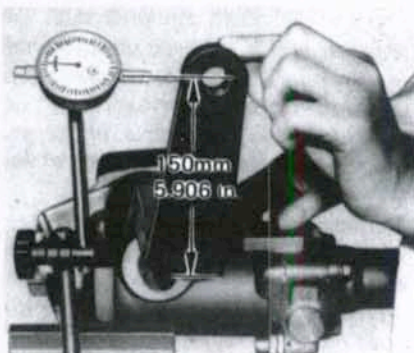
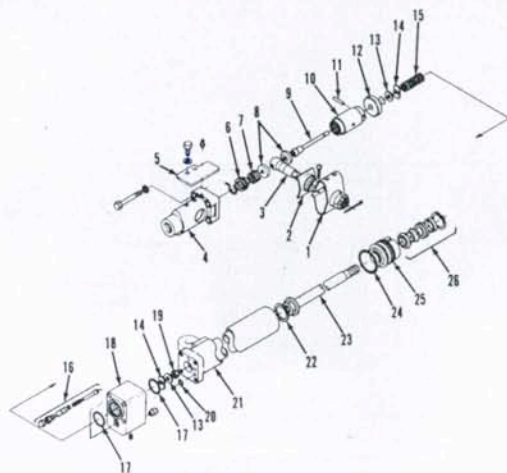

Fig. 37—Check sector gear backlash using a dial indicator.

Fig. 39—Exploded view of power steering booster unit used on some tractors.

1. Retainer
2. Seal
3. Ball stud
4. Housing
5. Stop plate
6. Screw
7. Spring
8. Seats
9. Actuator rod
10. Sleeve
11. Pin
12. Cap
13. Washer
14. Valve spool retainers
15. Centering spring
16. Relief valve assy.
17. "O" rings
18. Valve assy.
19. Nut
20. "O" ring
21. Cylinder
22. Piston ring
23. Piston & rod
24. "O" ring
25. Cylinder end
26. Rod seal assy.



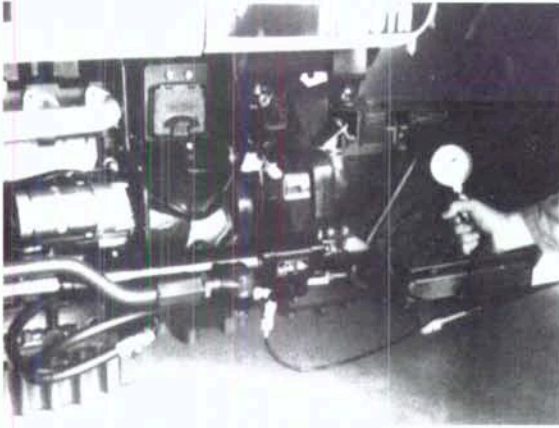

Fig. 39A—To check relief valve opening pressure on booster type steering, install a pressure gage in valve housing test port as shown. Refer to text.

seal (2) from spool housing (4). Remove retaining cap screws, then separate spool valve assembly, valve housing and cylinder assembly. Remove nut (19) securing valve spool, then separate valve spool, center spring (15) and retainers (14) from actuator rod (9). Remove stud adjusting screw (6), spring (7), seats (8), stud (3) and sleeve (10) from housing (4). Count number of turns required to remove relief valve adjuster screw (16) from valve body. Unscrew piston rod retainer (25) and withdraw piston and rod assembly. Remove and discard all seals and "O" rings.

Clean and inspect all parts for excessive wear, scoring or other damage. Renew components which do not meet following specifications: Maximum allowable clearance between valve spool and housing is 0.04 mm (0.0016 inch). Maximum allowable clearance between piston and cylinder bore should not exceed 0.2 mm (0.008 inch).

To reassemble booster unit, reverse the disassembly procedure. Renew all seals and "O" rings. Lubricate all parts with clean hydraulic oil prior to reassembly. Tighten cylinder rod end (25) to torque of 79-98 N·m (60-70 ft.-lbs.). When reinstalling relief valve assembly, turn adjuster screw into valve

body same number of turns required for removal. Apply light coat of grease to valve sleeve and ball stud (3). Reassemble valve spool and centering spring being careful not to damage "O" ring in cap (12). Tighten retaining nut to a torque of 7.8 N·m (70 in.-lbs.). Assemble actuator housing, valve housing and cylinder assembly and tighten mounting cap screws evenly to a torque of 19.6 N·m (15 ft.-lbs.).

To reinstall booster unit, reverse the removal procedure. Operate steering in both directions several times to purge air from system. Check and adjust relief valve pressure setting as outlined in paragraph 16.

STEERING PUMP

18. Hydraulic power supply for power steering system on Models L235, L275 and L305 is the hydraulic system pump mounted on right side of engine. Pump output is first routed to a flow divider valve which directs a priority flow of oil to power steering, the remaining pump flow is directed to hitch control valve.

On Models L345 and L355, a separate hydraulic pump is used for steering

system. The pump is mounted in tandem behind hydraulic hitch system pump. All pumps are located on right side of engine and are driven by engine fuel camshaft.

All Models So Equipped

19. PRESSURE TEST. To check pump discharge pressure, disconnect pump pressure outlet pipe and connect a 20000 kPa (3000 psi) pressure gage with flow control valve as shown in Fig. 40 or 41. Direct return hose from flow control valve back into reservoir.

CAUTION: With test equipment connected as outlined, pressure relief valve will be eliminated. **BE SURE** flow control valve is fully open before starting engine. **DO NOT** close control valve further after specified pressure is reached. Otherwise, pump damage will occur.

With flow control valve open, start engine and operate until fluid reaches operating temperature. Set engine speed at 2600 rpm, then slowly close flow control valve until pump delivery pressure is within range of 13250-14700 kPa (1920-2130 psi). If specified pressure cannot be obtained, hydraulic pump should be removed and repaired or renewed.

Models L235, L275 and L305

20. R&R AND OVERHAUL. To remove hydraulic pump, first thoroughly clean pump and hydraulic lines. Disconnect hydraulic lines from pump. Remove pump mounting cap screws and withdraw pump assembly.

On Models L235 and L275, remove hydraulic filter and base. On all models, place a scribe mark across pump sections, then remove end cover (10—Fig. 42 or 43). Carefully separate pump com-

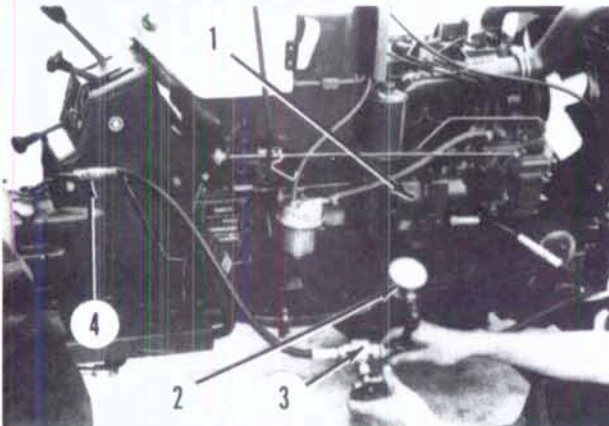

Fig. 40—Pressure gage and flow control valve connected to check hydraulic pump discharge pressure on Models L235, L275 and L305.

1. Hydraulic pump
2. Pressure gage
3. Flow control valve
4. Return to reservoir

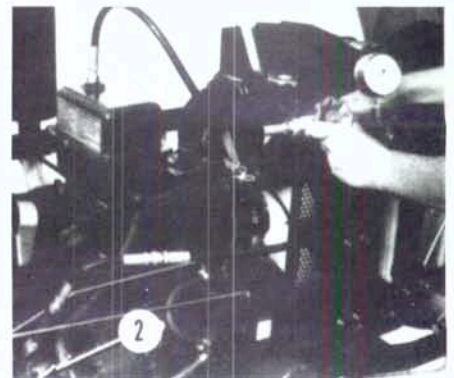

Fig. 41—On Models L345 and L355, connect test gage and flow control valve as shown to check output of steering pump (2).

ponents noting location so parts can be reinstalled in their original position. Remove oil seal from pump front plate if renewal is necessary.

Inspect all parts for excessive wear, scoring or other damage. The only parts available are seal rings and front oil seal. Renew pump if the following specifications are not met. Clearance between gear outside diameter and case inside diameter should not exceed 0.15 mm (0.006 inch). Maximum allowable clearance between bushing and gear shaft is 0.12 mm (0.005 inch).

Lubricate all parts with clean oil during reassembly. Renew all seal rings and front oil seal. Assemble pump sections aligning match marks made during disassembly. Tighten end cover mounting cap screws evenly to a torque of 32-39 N·m (24-29 ft.-lbs.).

Be sure oil supply and discharge tube "O" rings are in place when reconnecting to pump. Check fluid level of reservoir and add recommended hydraulic oil if necessary. Start engine and turn steering from side to side to purge air from system.

Models L345 and L355

21. R&R AND OVERHAUL.

Thoroughly clean outside of pump and surrounding area prior to removal. Disconnect hydraulic lines, remove pump mounting cap screws and withdraw pump assembly.

Prior to disassembling pump, scribe a mark across pump sections to aid in reassembly. Remove end cover (1-Fig. 44) and carefully separate components from case (9). Note location of components so they can be reinstalled in their original positions.

Inspect all parts for excessive wear, scoring, corrosion or other damage and renew as necessary. If the following wear specifications are exceeded, renew pump assembly. Inside diameter of pump case must not exceed 31.09 mm (1.224 inches). Maximum allowable clearance between bushing and gear shaft is 0.18 mm (0.007 inch).

Lubricate all parts with clean oil during reassembly. Renew all seal rings and oil seal. Align match marks when reinstalling end cover and tighten cap screws evenly to a torque of 26-32 N·m (19-24 ft.-lbs.) Be careful not to damage "O" ring (12) when assembling pump to adapter plate (13). Tighten mounting cap screws to a torque of 24-27 N·m (18-19 ft.-lbs.). Make sure "O" rings are in place when reconnecting oil supply and discharge tubes to pump.

Refill reservoir with recommended hydraulic fluid. Start engine and cycle steering several times to purge air from system.

Fig. 42—Exploded view of hydraulic pump used on Models L235 and L275.

1. Snap ring
2. Oil seal
3. Case
4. "O" rings
5. Bushings
6. Idler gear
7. Drive gear
8. "O" ring
9. "O" ring
10. End cover

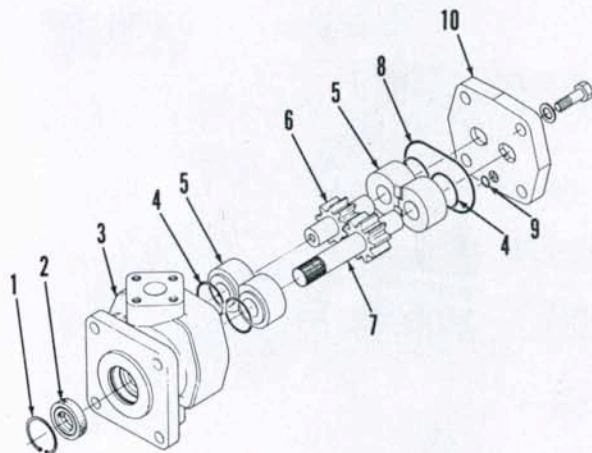

Fig. 43—Exploded view of hydraulic pump used on Model L305.

1. Oil seal
2. Front cover
3. Seal ring
4. Bushing seal
5. Gasket ring
6. Bushings
7. Case
8. Drive gear
9. Idler gear
10. End cover

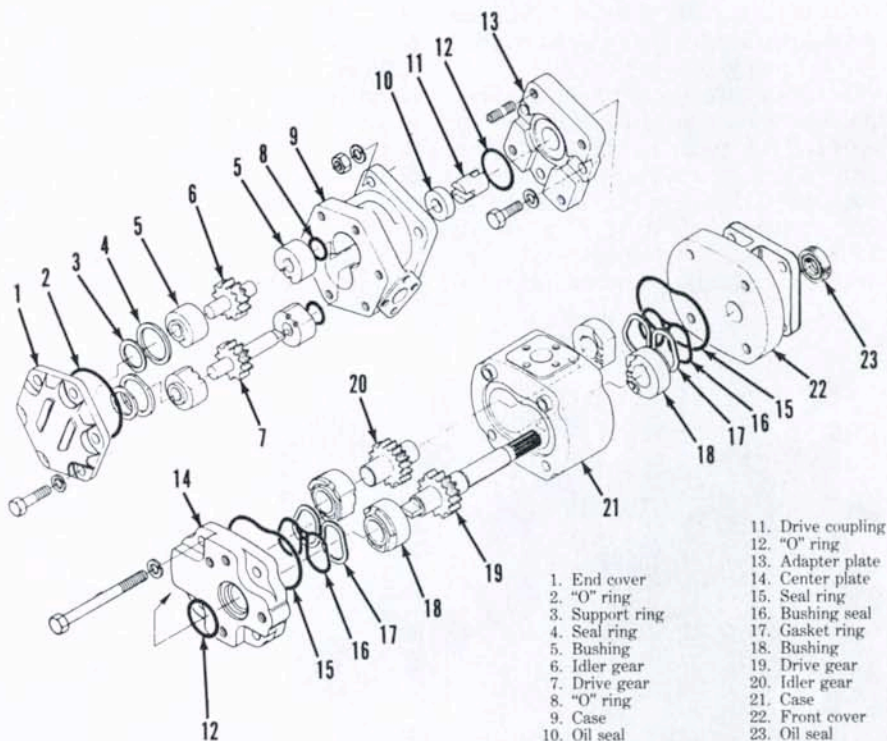
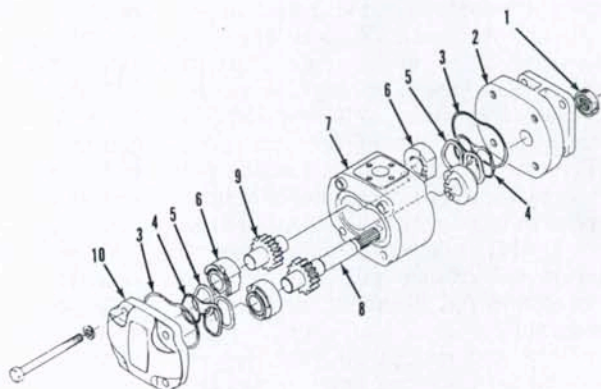

Fig. 44—Exploded view of tandem hydraulic pumps used on Models L345 and L355. Rear pump (items 1 through 10) supplies power steering system.

ENGINE AND COMPONENTS

R&R ENGINE

All Models

22. To remove engine and clutch as a unit, first drain cooling system, engine oil, transmission oil, power steering reservoir (if equipped) and front wheel drive differential housing (if equipped). Remove front axle assembly as follows: Remove hood, side panels and upper support rail (if equipped), muffler and battery. Disconnect radiator hoses and air cleaner hose. Disconnect drag link end using a suitable puller. On front wheel drive models, unbolt and remove drive shaft. On all models, support tractor under clutch housing and support front end unit with a suitable hoist or splitting stand. Remove front axle bracket mounting cap screws, then roll front end away from engine. To separate engine from clutch housing, disconnect wiring to engine as necessary. Disconnect fuel supply line, fuel return line and hydraulic hoses and tubes. Disconnect throttle control linkage, engine stop rod (if equipped), hour-meter cable and decompression cable. Support engine with a suitable hoist, remove cap screws securing flywheel housing to clutch housing and separate engine from transmission.

To reinstall engine, reverse the removal procedure. Tighten clutch housing mounting cap screws to a torque of 49-54 N·m (36-41 ft.-lbs.). Tighten front axle bracket fasteners to the following torques: M10 nut to 61-71 N·m (45-50 ft.-lbs.), M10 bolt to 48-56 N·m (36-41 ft.-lbs.) and M12 nut or bolt to 78-90 N·m (58-66 ft.-lbs.).

CYLINDER HEAD

All Models

23. To remove cylinder head, first drain cooling system and disconnect battery cables. Remove hood, muffler and side covers (if equipped). Remove upper radiator hose, coolant return hose and intake manifold hose. Disconnect decompressor control cable. Remove injection lines and nozzle assemblies and cap all exposed fittings to prevent entry of dirt. Remove alternator adjusting bracket. Remove valve lever cover. Remove valve levers and shaft assembly and withdraw push rods. Remove cap screws and nuts securing cylinder head and lift head off cylinder block.

One or more shims may be installed between gasket and cylinder head to adjust clearance between cylinder head and piston tops. Identify shims when

cylinder head is removed, then install an equal number of shims when head is reinstalled. To check piston to head clearance, insert a soft lead wire through injection nozzle holder hole. Rotate crankshaft by hand until lead wire is flattened by piston top. Measure thickness of flattened wire to determine top clearance which should be 0.7-0.9 mm (0.028-0.035 inch).

NOTE: Because of minimum amount of clearance that exists between valves and piston tops, loosen valve lever adjusting screws before reinstalling valve levers and shaft assembly to prevent possible damage to valves.

Check cylinder head surface for distortion using a straightedge and feeler gage. If a 0.05 mm (0.002 inch) feeler gage can be inserted between cylinder head and straightedge, head surface should be refaced with a surface grinder. A maximum of 0.5 mm (0.020 inch) of material may be removed to true cylinder head surface. Refer to paragraph 25 for valve head recession specifications.

When installing cylinder head, use new head gasket and install shims (if used) between gasket and cylinder head. Be sure sealing surfaces are clean and dry. Apply light coat of engine oil to threads of retaining nuts and cap

screws. Tightening torque on all models is 73.5-78.4 N·m (55-58 ft.-lbs.). On all models, tighten nuts and cap screws evenly in three stages using recommended sequence shown in Fig. 45.

Adjust valve clearance as outlined in paragraph 25 and compression release mechanism as outlined in paragraph 24. Retorque cylinder head cap screws and nuts after running engine for approximately 30 minutes using proper tightening sequence.

COMPRESSION RELEASE

All Models

24. Compression release mechanism is contained within valve lever cover. When decompressor knob is pulled, decompressor shaft rotates allowing adjusting screws to contact exhaust valve levers. The decompressor screws will hold exhaust valves slightly open, reducing compression resistance when starting engine, until decompressor knob is returned to normal operating position.

To adjust compression release, remove adjusting covers from valve lever cover (Fig. 46). Pull decompressor knob out, then turn crankshaft by hand until exhaust valve being adjusted is completely closed (piston at TDC compression stroke). Turn decompressor screw down until it contacts valve lever,

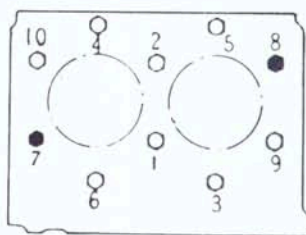

Flywheel side

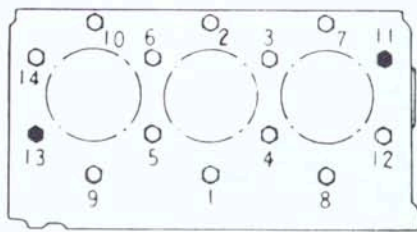
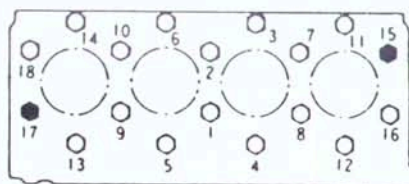

Fig. 45—When tightening cylinder head bolts, use appropriate sequence shown for two, three or four cylinder engines.

○ Bolt

● Nut



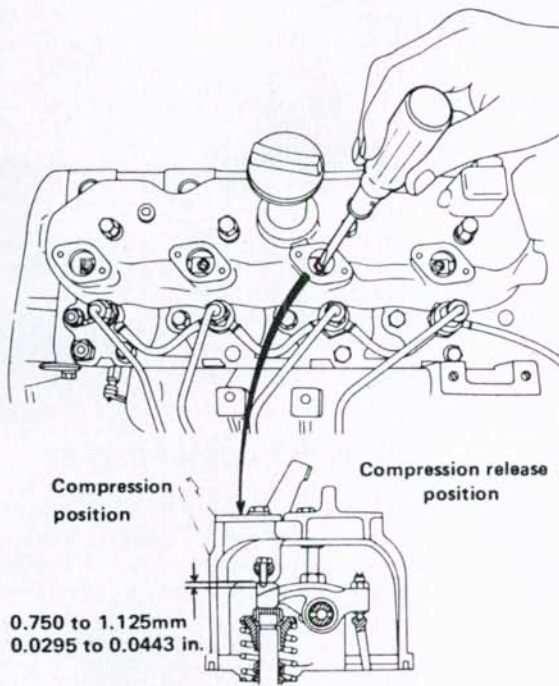

Fig. 46—Cross-sectional view of decompressor mechanism and adjustment point.

(0.007-0.009 inch) for both intake and exhaust on all models.

CAUTION: Due to close clearance between valves a pistons, severe damage can result from inserting feeler gage between valve stem and valve lever with engine running. **DO NOT** attempt to adjust valve clearance with engine running.

To adjust valve clearance, proceed as follows: Loosen valve lever adjusting screw locknuts. Rotate crankshaft by hand to position number one piston at top dead center of compression stroke. Using a feeler gage to measure clearance, adjust valves for number one cylinder. Adjust remaining valves in sequence of firing order after positioning each piston at top dead center of compression stroke.

VALVE GUIDES

All Models

26. Intake and exhaust valve guides are semi-finished and must be reamed after installation in cylinder head. Intake and exhaust valve guides are not interchangeable as exhaust guide is equipped with a "carbon scraper" at lower end of guide (Fig. 47). Press new guides into cylinder head until guide shoulder is seated against surface of head. All models are equipped with cup-type stem seals which fit over stem end of valve guide.

Desired operating clearance of valve stem in guide is 0.04-0.07 mm (0.0016-0.0028 inch). Maximum

then turn screw down an additional 1 to 1½ turns to obtain specified valve opening of 0.750-1.125 mm (0.030-0.044 inch). Tighten locknut while holding adjusting screw. Repeat adjustment procedure for remainder of exhaust valves.

NOTE: After adjustment is completed, pull knob out and turn crankshaft by hand to make certain valves do not contact piston tops.

VALVES AND SEATS

All Models

25. Intake and exhaust valves are not interchangeable. All valves seat directly in cylinder head. Valve face and seat angles are 45 degrees for all valves. Recommended valve seat width is 2.1 mm (0.080 inch). Valve stem diameter is 7.960-7.975 mm (0.3134-0.3140 inches)

for all valves. Face of valves should be recessed 1.1-1.3 mm (0.043-0.051 inch) below surface of cylinder head. Maximum allowable recession is 1.6 mm (0.063 inch).

Whenever valves are renewed or resealed, be sure to adjust compression release mechanism as previously outlined.

Valve clearance, gap between valve stem end and valve lever, is adjusted with engine cold on all models. Recommended gap is 0.18-0.22 mm

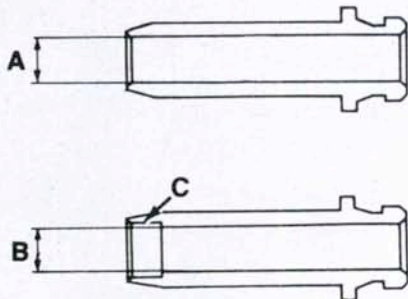
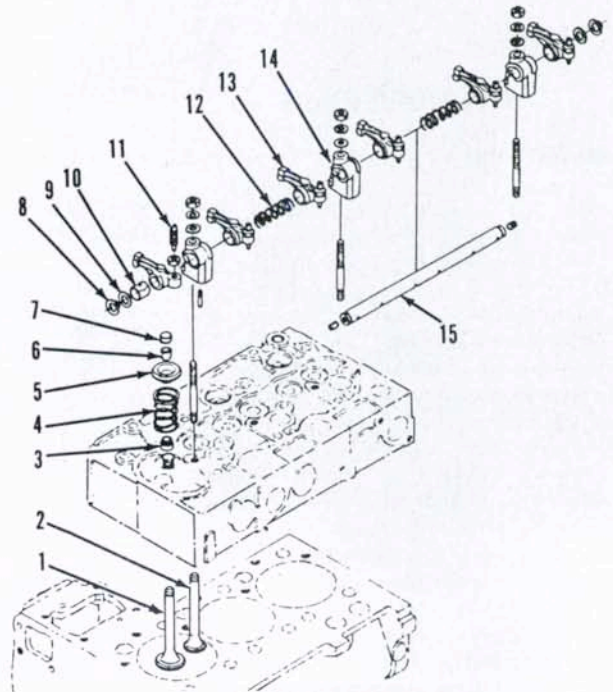

Fig. 47—Exhaust valve guide is equipped with a "carbon scraper" (C) and is not interchangeable with intake guide. Note scraper area when measuring inside diameter (A and B) of guides.

Fig. 48—Exploded view of valves and valve lever assembly.

1. Intake valve
2. Exhaust valve
3. Valve stem seal
4. Spring
5. Retainer
6. Keepers
7. Cap
8. Snap ring
9. Washer
10. Bushing
11. Adjusting screw
12. Spring
13. Valve lever
14. Bracket
15. Shaft



allowable clearance is 0.10 mm (0.0039 inch). Recommended finished inside diameter of valve guides is 8.015-8.030 mm (0.3156-0.3161 inch).

VALVE SPRINGS

All Models

27. Valve springs are interchangeable for intake and exhaust valves. Approximate free length is 42 mm (1.65 inches) and minimum allowable free length is 41.2 mm (1.62 inches) on all models. Renew springs which are distorted, heat discolored or fail to meet following test specifications: Springs should test 117.7 N (26.5 pounds) when compressed to a length of 35.15 mm (1.384 inches). Minimum test specifications are 100 N (22.5 pounds) at 35.15 mm (1.384 inches).

VALVE LEVERS

All Models

28. Intake and exhaust valve levers (rocker arms) are interchangeable on all models. However, it is recommended that valve levers be reinstalled in their original positions if not being renewed. All valve levers are equipped with renewable bushings (10—Fig. 48). When installing new bushing, be sure hole in bushing is aligned with corresponding hole in valve lever. Recommended operating clearance of shaft in valve levers is 0.02-0.07 mm (0.0008-0.0028

inch) and allowable limit is 0.15 mm (0.006 inch). Shaft diameter should be 13.973-13.984 mm (0.5501-0.5506 inch) and bushing inside diameter should be 14.002-14.043 mm (0.5513-0.5529 inch).

Valve levers and shaft are lubricated by oil metered to shaft support bracket from rear camshaft bearing. When assembling valve lever assembly, make sure all oil passages are open and properly positioned.

CAM FOLLOWERS

All Models

29. All models are equipped with barrel type cam followers (tappets) which can be removed from the top after removing cylinder head. Cam followers operate directly in unbushed crankcase bores on all models.

Check for wear or other damage and renew if necessary. Check camshaft at same time and renew if cam lobe surface is chipped, scored or excessively worn. Refer to paragraph 33.

VALVE TIMING

All Models

30. Valve timing is correct when timing marks on timing gear train are aligned as shown in Fig. 49 or 50. Timing gear cover must be removed to check timing marks. Refer to following paragraph.

TIMING GEAR COVER

All Models

31. To remove timing gear cover, first separate front axle assembly from engine as follows: Drain cooling system. Remove hood, muffler, side covers and side rails (if equipped). Disconnect battery cables and remove battery. Disconnect upper and lower radiator hoses and intake manifold hose. Disconnect steering drag link from front axle. On tractors equipped with booster-type power steering, disconnect booster cylinder from front support. On tractors with front-wheel drive, remove drive shaft. On all models, support tractor underneath clutch housing and front axle. Remove fasteners securing front axle support to engine block, then roll front axle assembly and radiator as a unit away from engine.

Remove injection pump side cover, then disconnect governor spring (1—Fig. 51) from governor lever (3). Remove speed control plate (2), then disconnect start spring (5) from gear cover (6). Remove fan belt, then use a suitable puller to remove crankshaft pulley. Remove alternator and mounting bracket. Remove hourmeter drive (if equipped) from front cover. Disconnect water pump by-pass hose. Remove retaining cap screws and withdraw timing gear cover.

Crankshaft front oil seal can be renewed at this time. Seal should be installed with lip to the rear and front edge flush with front of cover bore. Apply grease to oil seal lip prior to reinstalling front cover.

When reinstalling timing gear cover, be sure all "O" rings are in position and water inlet nipple in cylinder block is free of rust, burrs or other imperfections which might damage "O" ring. Be sure hourmeter drive tang engages slot

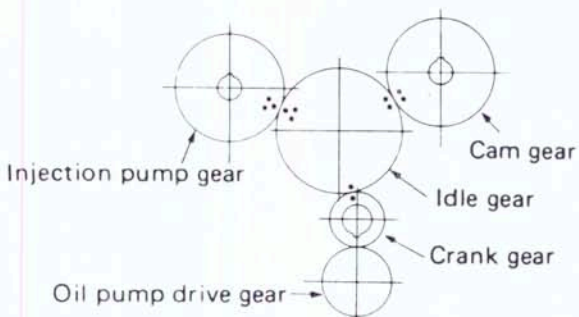

Fig. 49—View of timing gear marks correctly aligned for Models L185, L235, L245, L275, L295 and L305.

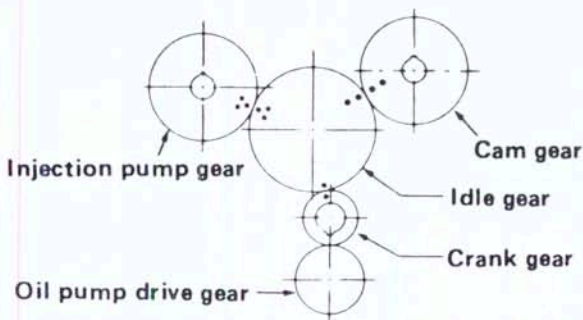

Fig. 50—On Models L285, L345 and L355, timing gear marks should be aligned as shown.

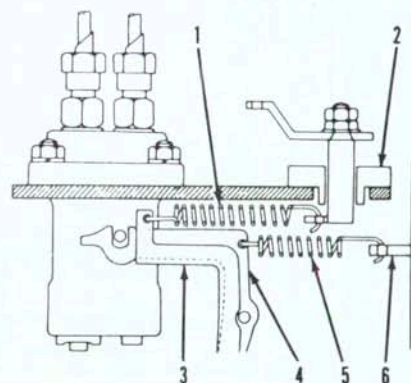

Fig. 51—View of governor linkage and springs.
1. Governor spring
2. Speed control plate
3. Governor lever
4. Fork lever
5. Start spring
6. Timing gear cover

in end of fuel camshaft. Complete reassembly by reversing disassembly procedure.

TIMING GEARS

All Models

32. Refer to Fig. 52 for an exploded view of typical timing gear set and associated parts. Normal backlash between any two gears in timing train is 0.042-0.115 mm (0.0017-0.0045 inch) with a maximum allowable limit of 0.3 mm (0.012 inch).

Crankshaft gear (33) is light press fit on shaft and can be removed using a suitable puller. On Models L285 and L345, a separate oil pump drive gear, installed in front of crankshaft gear, is also a light press fit. To install new gear, heat first to a temperature of 80°-95°C (175°-200°F) and install immediately. Make sure timing mark faces forward.

Camshaft gear (35) is a light press fit on shaft. Gear and shaft should be removed from cylinder block as a unit, then press shaft out of gear.

Injection pump gear (2) is a light press fit on fuel camshaft and is retained by a snap ring. Gear contains injection pump governor flyball components and service procedures are outlined in DIESEL FUEL SYSTEM section.

Idler gear (23) is equipped with renewable bushings (22 and 24).

When reassembling timing gears, align timing marks as shown in Fig. 49 or 50.

CAMSHAFT

All Models

33. To remove camshaft, first remove timing gear cover as previously outlined. Remove cylinder head and lift out cam followers. Remove two cap screws retaining camshaft thrust plate, then withdraw camshaft and drive gear as a unit. Be careful not to damage camshaft or bearing bores. Gear can be removed using a suitable press. Thrust plate controls camshaft or bearing bores. Gear can be removed using a suitable press. Thrust plate controls

camshaft end play.

Camshaft bearing journal diameter should be 39.934-39.950 mm (1.5722-1.5728 inches). Camshaft operates in unbushed bores in cylinder block. Bearing bore inside diameter should be 40.000-40.025 mm (1.5748-1.5758 inches). Desired operating clearance is 0.050-0.091 mm (0.0020-0.0036 inch) with a maximum limit of 0.15 mm (0.006 inch). Measured cam height should be 33.36 mm (1.313 inches) and minimum allowable height is 33.31 mm (1.311 inches).

When reinstalling camshaft, thoroughly lubricate cams and bearing journals. Be sure to align timing marks as shown in Fig. 49 or 50.

ROD AND PISTON UNITS

All Models

34. Connecting rod and piston units may be removed from above after removing cylinder head and oil pan. Be sure to remove ring ridge (if present) from top of cylinder before attempting to push piston out. Be sure to identify piston, rod and cylinder from which they came so units can be reassembled in original positions.

Before removing piston from rod, mark top of piston in relation to alignment marks on connecting rod (Fig. 53) and identify piston and connecting rod as a pair to ensure correct assembly.

When reinstalling piston and rod units, be sure connecting rod match marks (Fig. 53) are aligned and facing toward injection pump side of engine. Apply engine oil to connecting rod cap screws and tighten to a torque of 37-41 N·m (27-30 ft.-lbs.).

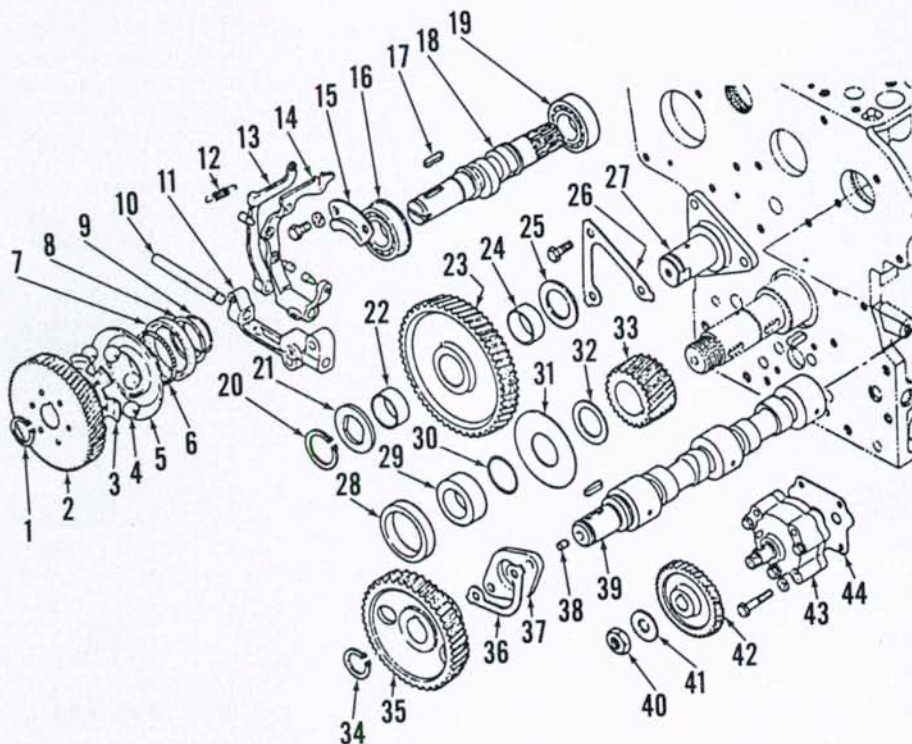

Fig. 52—Exploded view of timing gears and associated parts used on all tractors. Models L285 and L345 are equipped with a separate oil pump drive gear mounted in front of crankshaft gear.

- | | | | |
|------------------------|--------------------|----------------------|--------------------|
| 1. Snap ring | 12. Spring | 23. Idler gear | 34. Snap ring |
| 2. Injection pump gear | 13. Governor lever | 24. Bushing | 35. Camshaft gear |
| 3. Ball guide | 14. Fork lever | 25. Washer | 36. Washer plate |
| 4. Governor balls | 15. Retainer plate | 26. Lock plate | 37. Thrust plate |
| 5. Sleeve | 16. Bearing | 27. Idler gear shaft | 38. Plug |
| 6. Thrust bearing | 17. Key | 28. Seal | 39. Camshaft |
| 7. Case | 18. Fuel camshaft | 29. Sleeve | 40. Nut |
| 8. Retaining ring | 19. Bearing | 30. "O" ring | 41. Washer |
| 9. Retaining ring | 20. Snap ring | 31. Oil slinger | 42. Oil pump gear |
| 10. Shaft | 21. Slotted washer | 32. Washer | 43. Oil pump Assy. |
| 11. Fork lever holder | 22. Bushing | 33. Crankshaft gear | 44. Gasket |

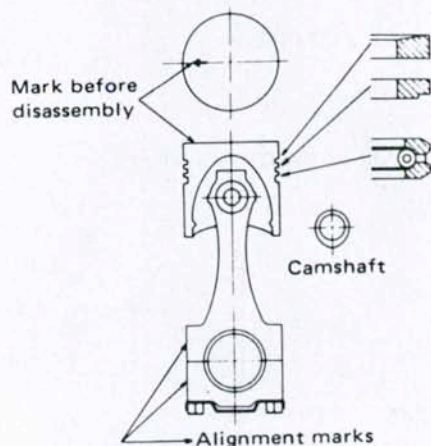

Fig. 53—Mark top of piston in relation to identification marks on connecting rod prior to disassembly. Marks should face away from camshaft side of engine. Be sure piston rings are installed as shown.

PISTON AND RINGS

All Models

35. Three-ring, cam ground aluminum pistons are used on all models. Pistons and rings are available in standard size and 0.5 mm (0.020 inch) oversize.

Piston ring end gap should be 0.30-0.45 mm (0.012-0.018 inch) for compression rings and 0.25-0.40 mm (0.010-0.016 inch) for oil control ring. Maximum allowable end gap for any ring is 1.25 mm (0.049 inch). Top compression ring is half-keystone type as shown in Fig. 53 and side clearance is not measured. Second compression ring should have a side clearance of 0.09-0.12 mm (0.004-0.005 inch). Oil control ring side clearance should be 0.02-0.05 mm (0.001-0.002 inch).

When installing rings onto piston, be sure manufacturer's name or "TOP" mark on ring is towards top of piston. Make certain notched outer edge on second compression ring (Fig. 53) is facing down. Position coil expander joint on opposite side of oil control ring gap. Stagger rings on piston so end gaps are 90 degrees apart with no gap aligned with piston pin.

PISTON PINS

All Models

36. The full floating piston pin is a transition fit in piston bosses at room temperature. Heat piston prior to reassembly to ease piston pin installation. Piston pins are available in standard size only.

Inside diameter of pin bore in piston should be 23.000-23.013 mm (0.9055-0.9060 inch) and maximum usable bore diameter is 23.053 mm (0.9076 inch). Piston pin diameter should be 23.002-23.011 mm (0.9056-0.9059 inch). Pin should have an operating clearance of 0.014-0.038 mm (0.0006-0.0015 inch) in connecting rod bushing. Maximum allowable clearance is 0.15 mm (0.006 inch).

CYLINDER SLEEVES

All Models

37. Cylinder sleeves used in all models are dry-type sleeves which are a tight press fit in cylinder block. Sleeves which are worn beyond the allowable limit of 0.15 mm (0.006 inch) may be bored and honed to accept 0.5 mm (0.020 inch) oversize pistons and rings. When oversized sleeve is worn beyond allowable limit, sleeve must be renewed. New sleeve should be pressed into block

bore until flush with top of block. New sleeves are semi-finished and must be bored and honed to obtain desired clearance of 0.075-0.100 mm (0.003-0.004 inch) for piston skirt. Standard finished diameter of sleeve is as follows: On Models L185, L235, L245, L285 and L345, diameter is 76.00-76.02 mm (2.992-2.993 inches). On Models L275, L295, L305 and L355, diameter is 82.00-82.02 mm (3.228-3.229 inches).

CONNECTING RODS AND BEARINGS

All Models

38. Connecting rod bearings are slip-in, precision type, renewable from below after removing oil pan and connecting rod cap. When installing connecting rods, make certain match marks on cap and rod are aligned (Fig. 53) and face AWAY from camshaft side of engine. Connecting rod bolt torque is 37-41 N·m (27-30 ft.-lbs.) with threads oiled.

Standard crankpin diameter is 43.959-43.975 mm (1.7307-1.7313 inches) for all models. Desired operating clearance between crankpins and bearings is 0.035-0.093 mm (0.0014-0.0037 inch) and maximum allowable clearance is 0.20 mm (0.008 inch). Connecting rod bearings are available in standard size and also 0.20 mm (0.008 inch) and 0.40 mm (0.016 inch) undersizes.

CRANKSHAFT AND MAIN BEARINGS

All Models

39. On all models crankshaft and main bearing assemblies are removed from rear of engine as follows: Remove engine assembly, then remove rod and

piston units, timing gear cover, crankshaft gear, flywheel and rear bearing cover. Remove bearing case retaining cap screws (20 - Fig. 54), then bump crankshaft and bearings rearward out of cylinder block. Note that bearing cases are minimum clearance in cylinder block bores to provide oil pressure transfer through drillings in bearing cases.

Front main bearing (2) is a one-piece bushing type, pressed into front face of cylinder block. Remainder of main bearings are two-piece bushing type contained in two-piece bearing cases (21). Crankshaft end play is controlled by thrust washers (25) located on rear main bearing.

Standard main journal diameter is 51.921-51.940 mm (2.044-2.045 inches). Desired diametral clearance in front main bearing is 0.040-0.118 mm (0.0016-0.0046 inch) and in remainder of bearings is 0.040-0.104 mm (0.0016-0.0041 inch). Maximum allowable clearance for all main bearings is 0.20 mm (0.008 inch). Bearings are available in standard size as well as 0.20 mm (0.008 inch) and 0.40 mm (0.016 inch) undersizes.

Crankshaft end play should be 0.15-0.30 mm (0.006-0.012 inch) with and allowable limit of 0.5 mm (0.020 inch). Thrust washers (25 - Fig. 54) are available in standard size and also 0.20 mm (0.008 inch) and 0.40 mm (0.016 inch) oversizes. When reinstalling thrust washers, be sure oil grooves are facing outward.

Reinstall crankshaft by reversing the removal procedure while noting following items: Assemble bearing cases starting with smallest outside diameter case at front of crankshaft. Be sure to align bearing case match marks. Tighten bearing case cap screws to a torque of 30-34 N·m (22-25 ft.-lbs.) and case

Fig. 54—Exploded view of crankshaft, main bearings, connecting rod and piston of the type used on all models. Some models do not use lock plates (8 and 11).

1. Crankshaft
2. Main bearing (front)
3. Pilot bearing
4. Gasket
5. Gasket
6. Bearing cover
7. Seal
8. Lock plate
9. Flywheel
10. Lock plate
11. Lock plate
12. Bearing insert
13. Connecting rod
14. Bushing
15. Snap ring
16. Piston pin
17. Piston
18. Oil control ring
19. Compression rings
20. Locating cap screw
21. Main bearing case
22. Lock plate or washer
23. Cap screw
24. Main bearing insert
25. Thrust washers

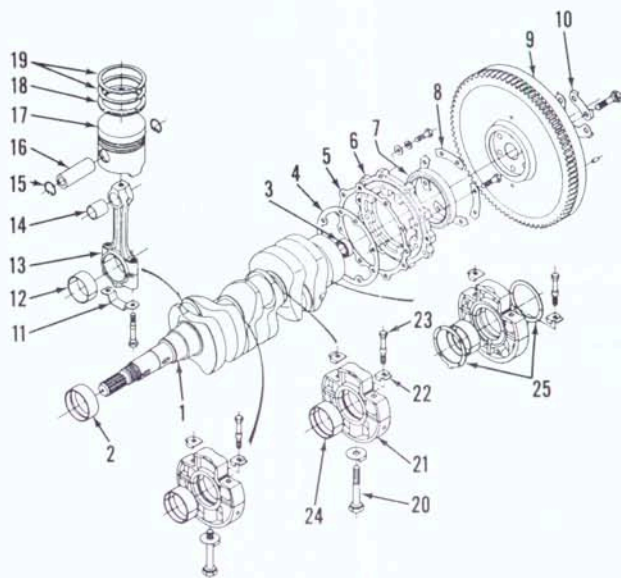

locating cap screws to 64-68 N·m (47-50 ft.-lbs.). Lubricate lip of rear oil seal (7) before reinstalling rear cover over crankshaft hub. Tighten flywheel retaining cap screws to a torque of 98-108 N·m (73-80 ft.-lbs.).

CRANKSHAFT REAR OIL SEAL

All Models

40. The lip type crankshaft rear oil seal (7—Fig. 54) is contained in rear bearing cover and can be renewed after splitting tractor between engine and clutch housing as outlined in paragraph 64 and removing clutch and flywheel.

Install new seal with lip towards inside and coat seal lip with grease prior to reassembly. Refer to following paragraph when reinstalling flywheel.

FLYWHEEL

All Models

41. Flywheel is retained to crankshaft flange by six evenly spaced cap screws and can be installed in any of six positions. To be sure flywheel will be reinstalled correctly, remove one of the retaining cap screws and spray flywheel and exposed cap screw hole with quick-drying paint. Then, when reinstalling flywheel, make certain paint marks are in register.

Flywheel ring gear is a shrink fit on flywheel. Heat gear evenly prior to installation, then install with beveled end of teeth towards front of flywheel.

Inspect pilot bearing and renew if necessary. Make sure mating surfaces of flywheel and crankshaft flange are clean and free of dirt, rust or burrs. Tighten retaining cap screws evenly to a torque of 98-108 N·m (73-80 ft.-lbs.).

OIL PUMP

All Models

42. The rotary type engine oil pump mounts on front of cylinder block and is driven by crankshaft gear. Pump can be removed after removing timing gear cover.

To check engine oil pressure, remove oil pressure switch and install a pressure gage (Fig. 55). With engine at operating temperature, check oil pressure at idle speed and rated speed. Pressure should be at least 100kPa (14 psi) at idle speed and should be within range of 295-440 kPa (43-60 psi) at rated engine speed.

Oil pump inner rotor to outer rotor operating clearance (Fig. 56) should be 0.10-0.16 mm (0.004-0.006 inch) and

maximum allowable clearance is 0.20 mm (0.008 inch). Clearance between body and outer rotor (Fig. 57) should be 0.11-0.19 mm (0.004-0.007 inch) and a maximum allowable clearance of 0.25 mm (0.010 inch). End clearance between rotors and cover should not exceed 0.2

mm (0.008 inch). Oil pump is available only as an assembled unit. Renew complete pump if it fails to meet specifications.

DIESEL FUEL SYSTEM

43. All models are equipped with an inline, multiple plunger type injection pump, pintle nozzles and glow plugs. Because of extremely close tolerances and precise requirements of all diesel components, it is of utmost importance that clean fuel and careful maintenance be practiced at all times. Unless necessary special tools are available, service on injectors and injection pump should be limited to removal, installation and exchange of complete assemblies. It is impossible to re-calibrate an injection pump or reset an injector without proper specifications, equipment and training.

FUEL FILTER

All Models

44. **MAINTENANCE.** On all models, filter life depends more on careful fuel system maintenance than it does on hours or conditions of operation. Necessity for careful filling with clean fuel cannot be over-stressed.

Fuel filter should be renewed after every 400 hours of operation or once a year, whichever occurs first. Renew filter immediately if water contamination is discovered or a decrease in engine power is evident. Air must be bled from system as outlined in following paragraph after installing new filter.

45. **BLEEDING.** To bleed air from fuel system, open fuel shut-off valve and loosen air vent plug (Fig. 58) on filter base. When steady stream of fuel appears at vent plug, tighten plug. Loosen vent plug on fuel injection pump until

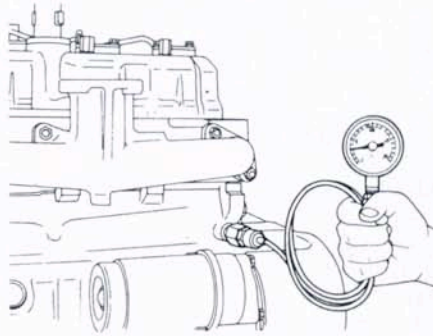

Fig. 55—Remove oil pressure switch and install pressure gage to check engine oil pressure.

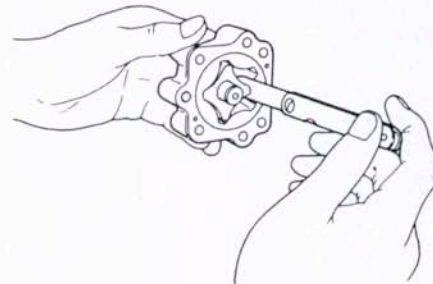

Fig. 56—Maximum allowable clearance between oil pump inner rotor and outer rotor is 0.20 mm (0.008 inch).

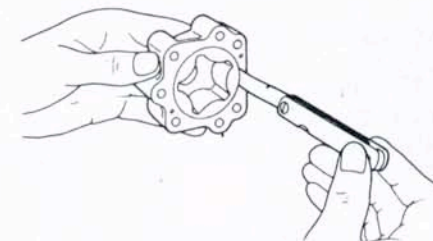

Fig. 57—Clearance between oil pump body and outer rotor should not exceed 0.25 mm (0.010 inch).

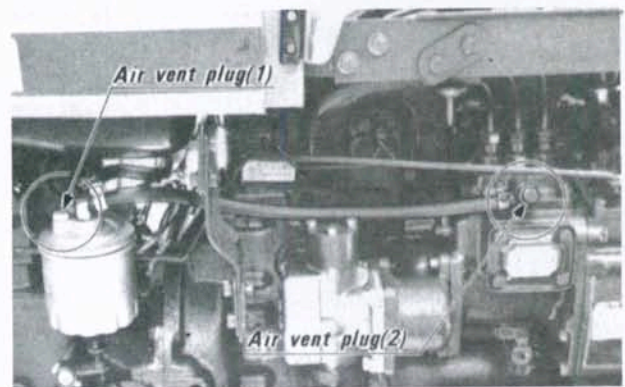

Fig. 58—Location of fuel system air vent plugs.

air-free fuel appears, then tighten vent plug.

If engine fails to start after bleeding air from filter and pump, loosen high pressure line connections at injector nozzles. Move throttle to run position and crank engine with starting motor until fuel appears at loosened injector line fittings. Tighten fittings and start engine.

INJECTION PUMP

A Bosch K type pump is used on all models. The injection pump is a completely sealed unit and no service work or disassembly other than that specified should be attempted without necessary special equipment and training.

All Models

46. TIMING TO ENGINE. On all models, start of injection should occur at 25° BTDC.

To check timing, disconnect fuel pressure line from injection pump front delivery valve holder. Place throttle control in maximum fuel position and pull decompressor knob out. Turn crankshaft slowly until wetness appears at discharge fitting of injection pump. At this point (beginning of injection), "F1" mark on flywheel should be aligned with timing check window.

If timing requires adjustment, remove shims (Fig. 59) between injection pump mounting flange and cylinder block to advance timing or add shims to retard timing. Adding or removing one shim will change timing about 1½ crankshaft degrees which is about 2.3 mm (3/32 inch) measured on flywheel rim.

47. REMOVE AND REINSTALL.

To remove injection pump, first thoroughly clean outside of pump and surrounding area. Shut off fuel and disconnect fuel supply line at injection pump. Remove high pressure lines leading to injectors. Remove side access cover or engine stop lever assembly if so equipped. Remove pump mounting stud

Injection timing adjusting shim

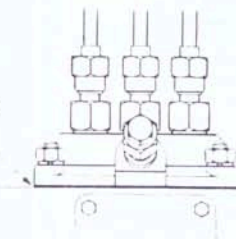

Fig. 59—Injection pump timing is adjusted by adding or removing pump mounting shims. Adding or removing one shim will change timing about 1½ crankshaft degrees.

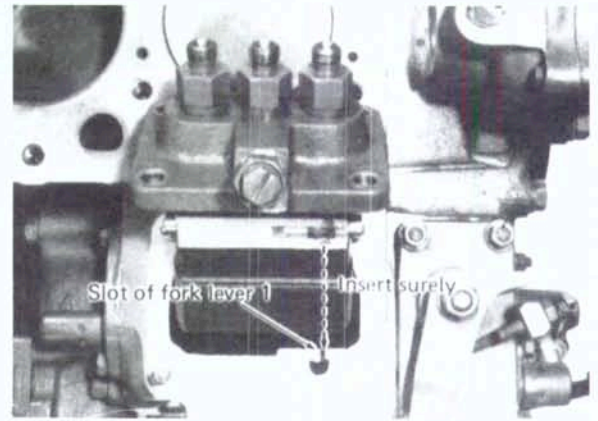
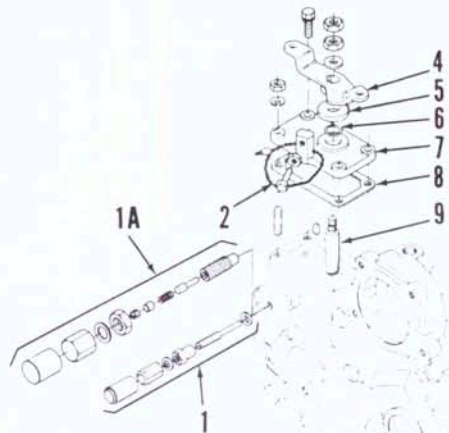
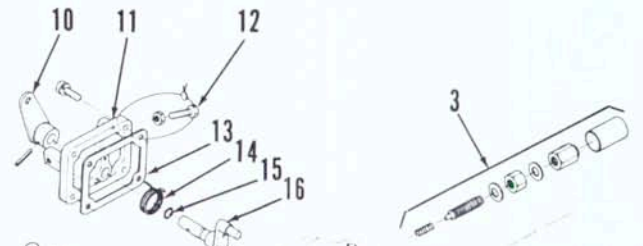
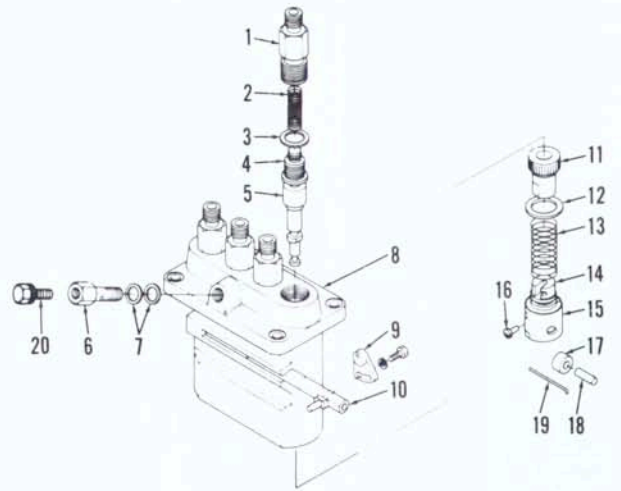

Fig. 60—When removing or installing injection pump, be sure pump rack pin is aligned with slot in fork lever and notch in crankcase.

Fig. 61—Exploded view of injection pump used on four cylinder engines. Other models are similar.

1. Delivery valve holder
2. Spring
3. Shim
4. Delivery valve assy.
5. Plunger
6. Inlet fuel fitting
7. Gaskets
8. Pump body
9. Adjusting plate
10. Control rack
11. Control sleeve
12. Washer
13. Spring
14. Spring seat
15. Tappet
16. Guide pin
17. Roller
18. Roller pin
19. Pin
20. Bleed screw



- | | |
|-----------------------------|---------------------|
| 1A. Maximum fuel stop assy. | 7. Control plate |
| 1. Maximum fuel stop assy. | 8. Gasket |
| 2. High idle stop screw | 9. Governor lever |
| 3. Low idle stop assy. | 10. Engine stop arm |
| 4. Speed control lever | 11. Side cover |
| 5. Friction washer | 12. Stop screw |
| 6. "O" ring | 13. Gasket |
| | 14. Spring |
| | 15. "O" ring |
| | 16. Stop lever |

Fig. 62—Exploded view of typical governor speed control components. Engine stop lever assembly (items 10 through 16) is used on Models L235, L275 and L355. Two different styles of fuel stop assembly (1A and 1) are shown.

nuts, align control rack pin with slot in crankcase (Fig. 60) and lift pump assembly from crankcase. Do not lose or damage shim pack located between pump flange and crankcase. Shims control pump timing and same number of shims must be reinstalled unless timing is to be changed.

When reinstalling pump, be sure to guide rack control pin into notch in governor arm and crankcase. Use removed shim pack unless timing is to be changed. Bleed air from system as previously outlined.

48. GOVERNOR LINKAGE ADJUSTMENT. High speed adjustment screw (2—Fig. 62) and maximum fuel limit stop (1 or 1A) should not normally require adjustment unless governor or injection pump is overhauled. Adjustments should be made by qualified personnel only.

Recommended slow idle speed is 800 to 850 rpm for all models. Adjustment is made by turning slow idle stop (3). High idle speed should be 2550 rpm for Model L285; 2750 rpm for Models L235, L275 and L355 and 2950 rpm for Models L185, L245, L295, L305 and L345. Turn high idle stop screw (2) for adjustment.

49. GOVERNOR AND FUEL CAMSHAFT. Governor assembly can be removed with the drive gear and fuel camshaft as a unit after removing injection pump, fuel feed pump (if so equipped), timing gear cover as outlined in paragraph 31, and hydraulic pump and drive gear from rear end of fuel cam-

shaft. Remove governor mounting cap screws and withdraw governor and camshaft as an assembly.

To disassemble, remove fork pivot shaft (18—Fig. 62A) and separate fork levers (21 and 22) and fork lever holder (24). Remove drive gear retaining ring (1), then remove gear and weight assembly (2 through 8) using a suitable puller. Governor weight thrust bearing (6) contains 39 loose balls. Be careful that none are lost when weight unit is disassembled.

Examine cupped race (5), balls (4) and ball travel surface on back of gear for furrowing or pitting and renew if damaged. Inspect fuel camshaft and bearings for scoring, wear or other damage and renew as necessary.

Reassemble by reversing the disassembly procedure. Be sure hydraulic pump drive gear is installed with hub facing forward. Bleed air from system, check timing and adjust governor linkage as previously outlined.

INJECTOR NOZZLES

WARNING. Fuel leaves injector nozzle with sufficient force to penetrate the skin. When testing, keep exposed portions of your body clear of nozzle spray and wear suitable eye protection. Make sure testing is performed in a well vented area.

All Models

50. TESTING AND LOCATING FAULTY NOZZLE. If engine does not run properly and a faulty injection nozzle is suspected, check for faulty nozzle

as follows: With engine running at slow idle speed, loosen injector line at each nozzle in turn to allow fuel to escape at union rather than enter the cylinder. As in checking spark plugs in a spark ignition engine, the faulty nozzle is the one that least affects engine operation when its fuel line is loosened.

Remove and test suspected nozzle (or install a new or reconditioned unit) as outlined in appropriate following paragraphs.

51. REMOVE AND REINSTALL. Before removing an injector, thoroughly clean injector, lines and surrounding area. Remove high pressure fuel line and disconnect bleed line. Unscrew nozzle holder from its mounting position on cylinder head.

When reinstalling injector, make sure seating surface in cylinder head is completely clean and free from carbon build-up. Use a new seal washer underneath nozzle holder and tighten to 30-49 N·m (22-36 ft.-lbs.) torque.

52. TESTING. A complete job of testing and adjusting injector requires use of special test equipment. Only clean, approved testing oil should be used in tester tank. Nozzle should be tested for opening pressure, nozzle leakage and spray pattern.

Before conducting test, operate tester lever until fuel flows, then attach injector. Close valve to tester gage and pump tester lever a few quick strokes to clear air from tester and to be sure nozzle valve is not stuck. Nozzle should open with a buzzing sound and cut off quickly at end of injection.

OPENING PRESSURE. Open valve to tester gage and operate tester lever slowly while observing gage reading. Opening pressure should be 13730-14700 kPa (1990-2135 psi) for all models.

Opening pressure is adjusted by changing thickness of shim (5—Fig. 63). A change in shim thickness of 0.1 mm (0.004 inch) will change opening pressure approximately 965 kPa (140 psi).

SEAT LEAKAGE. To check for leakage, actuate tester lever slowly to maintain a pressure 1000 kPa (150 psi) below opening pressure. There should be no accumulation of fuel at nozzle tip. A slight wetting is allowed after 10 seconds if no drops are formed. If fuel leakage is evident, injector must be disassembled, cleaned and overhauled as outlined in paragraph 53.

SPRAY PATTERN. Spray pattern should be well atomized and uniform,

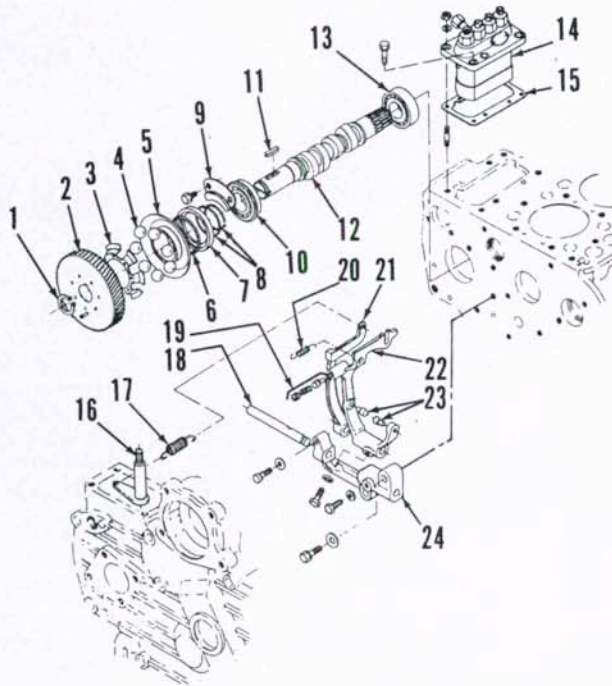

Fig. 62A—Exploded view of engine governor assembly and fuel camshaft. On some models, torque rise adjustment screw (19) is included in maximum fuel stop assembly (1A—Fig. 60).

1. Snap ring
2. Injection pump gear
3. Ball guide
4. Balls
5. Sleeve
6. Thrust bearing (39 balls)
7. Case
8. Retaining rings
9. Bearing retainer
10. Bearing
11. Key
12. Fuel camshaft
13. Bearing
14. Injection pump
15. Shims
16. Governor lever
17. Governor spring
18. Pivot shaft
19. Torque rise adjuster
20. Start spring
21. Governor lever
22. Fork lever
23. Pivot pins
24. Pivot block

emerging in a straight axis from nozzle tip. If pattern is wet, ragged or intermittent, nozzle must be overhauled or renewed.

53. OVERHAUL. Hard or sharp tools, emery cloth, wire brush or grinding compound must never be used. An approved nozzle cleaning kit is available through a number of specialized sources.

Wipe all dirt and loose carbon from exterior of nozzle assembly. Secure nozzle in a soft-jawed vise or holding fixture and remove nozzle nut (10—Fig. 63). Carefully separate parts and place in clean calibrating oil or diesel fuel as they are removed. Be sure parts from each injector are kept together and separate from other units.

Clean exterior surfaces with a brass wire brush, soaking in an approved carbon solvent, if necessary, to loosen hard carbon deposits. Rinse parts in clean diesel fuel immediately after cleaning to neutralize the solvent and prevent etching of polished surfaces.

Clean nozzle spray hole from inside using a pointed hardwood stick. Scrape carbon from pressure chamber using hooked scraper. Clean valve seat using brass scraper. Reclean all parts by rinsing in clean diesel fuel. Check nozzle fit by holding nozzle body vertically and lifting needle valve up about 1/3 of its length, then release needle. Needle must slide to its seat by its own weight. If nee-

dle movement is rough or sticky, reclean or renew nozzle valve assembly as necessary.

Reassemble injector while parts are immersed in diesel fuel to avoid contamination. Make sure pressure adjusting shim (5) is in place. Tighten nozzle nut to a torque of 59-78 N·m (44-58 ft.-lbs.). Do not overtighten as distortion may cause nozzle valve to stick and no amount of overtightening can stop a leak caused by scratches or dirt. Retest injector as previously outlined.

GLOW PLUGS

All Models

54. One glow plug is provided in precombustion chamber of each cylinder. To check glow plugs, disconnect wiring cable from glow plug terminal, then connect an ohmmeter across glow plug terminal and body. Resistance should be approximately 1.5 ohms. If resistance is zero ohms, glow plug is shorted. If resistance is infinite, an open circuit exists in glow plug.

COOLING SYSTEM

55. All models use a pressurized cooling system which raises coolant boiling point. All models except L185 use an impeller type centrifugal pump to provide forced coolant circulation and a thermostat to stabilize operating temperature.

Model L185 uses natural circulation in which the relative density of hot and cold liquid provides the means of coolant circulation. No coolant pump or thermostat is used in this system. It is of utmost importance that coolant level be maintained at a level which fully covers upper coolant hose inlet elbow.

RADIATOR

All Models

56. Radiator cap pressure valve is set to open at 88.3 kPa (12.8 psi) on all models. Some models are equipped with a whistle-type warning device attached to radiator overflow pipe. Make sure whistle is operative and properly connected to radiator.

To remove radiator, first drain coolant and remove hood. Disconnect radiator hoses and air cleaner hose. Remove mounting cap screws, then lift radiator from tractor.

THERMOSTAT

All Models Except L185

57. On models so equipped, the bypass type thermostat is located in coolant outlet elbow. Thermostat should begin to open at about 82°C (180°F) and be fully open at 95°C (203°F).

WATER PUMP

All Models Except L185

58. **R&R AND OVERHAUL.** Refer to appropriate Fig. 64, 65 or 66 for an exploded view of water pump. To remove pump, drain cooling system and remove radiator, if necessary, for access to pump. Remove fan belt, then unbolt and remove water pump.

To disassemble pump, remove fan pulley using a suitable puller. Unseat pump shaft bearing front retaining ring, then press shaft and bearings forward out of impeller and pump body. Remove seal assembly from pump body.

All water pump parts are available individually. To reassemble pump, reverse the disassembly procedure. On pumps equipped with fan pulley retaining nut, tighten nut to a torque of 70-78 N·m (50-58 ft.-lbs.).

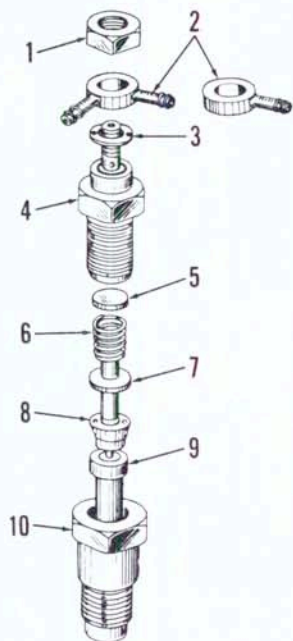
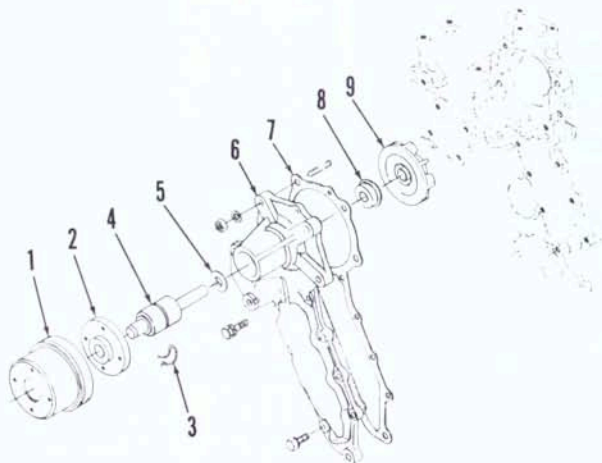

Fig. 63—Exploded view of injector unit used on all models.

- | | |
|---------------------|-------------------|
| 1. Nut | 6. Spring |
| 2. By-pass fitting | 7. Push rod |
| 3. Washer | 8. Spacer |
| 4. Pressure fitting | 9. Nozzle & valve |
| 5. Shim | 10. Nozzel nut |

Fig. 64—Exploded view of water pump used on Models L235, L275 and L355.

1. Pulley
2. Hub
3. Retainer
4. Shaft & bearing assy.
5. Slinger
6. Body
7. Gasket
8. Seal assy.
9. Impeller



FAN SHAFT

Model L185

59. To remove cooling fan and shaft assembly, drain cooling system and remove radiator. Remove fan belt and fan. Remove retaining nut (8—Fig. 67) and withdraw fan shaft (2), pulley (4) and bearings (5).

Renew parts as needed. Reinstall fan shaft assembly by reversing removal procedure.

ELECTRICAL SYSTEM

ALTERNATOR AND REGULATOR

All Models

60. TESTING. To check charging system, first disconnect wiring connector plug from alternator. Turn main

switch on, then measure voltage across E and F terminals (Fig. 68) of connector. Voltage should be at least 12 volts (battery voltage).

Check alternator no-load output as follows: Connect jumper lead between F and B terminals (Fig. 69) and ground E terminal to alternator frame. Connect voltmeter across B and E terminals as shown. Start engine and operate above 1300 rpm, then turn main switch off and disconnect ground cable from battery to make certain only alternator output voltage is indicated on voltmeter. Alternator voltage should be at least 14 volts.

Measure resistance of rotor coil, slip ring and brush by connecting an ohmmeter across terminals F and E (Fig. 70). Resistance should be six ohms and maximum allowable is 10 ohms.

If alternator does not meet test specifications, remove and overhaul.

To check regulator cut-in voltage, reconnect wiring connector to alternator. Connect voltmeter across N ter-

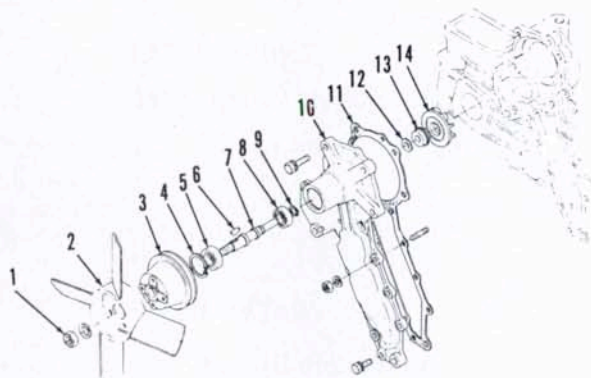

Fig. 65—Exploded view of water pump used on Models L245, L295 and L305.

1. Nut
2. Fan
3. Pulley
4. Retaining ring
5. Bearing
6. Key
7. Shaft
8. Bearing
9. Retaining ring
10. Body
11. Gasket
12. Slinger
13. Seal assy.
14. Impeller

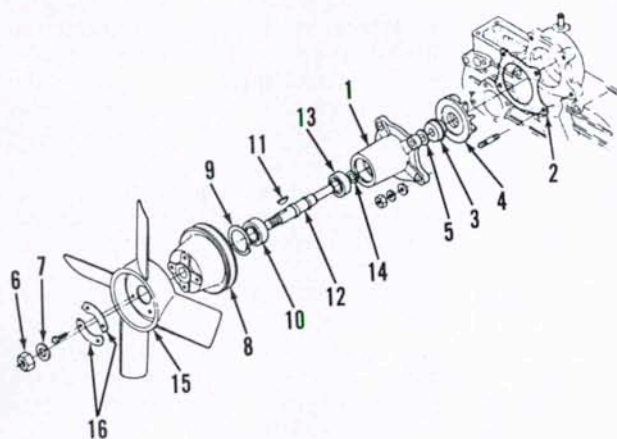

Fig. 66—Exploded view of water pump used on Models L285 and L345.

1. Body
2. Gasket
3. Seal assy.
4. Impeller
5. Slinger
6. Nut
7. Lockwasher
8. Pulley
9. Snap ring
10. Bearing
11. Key
12. Shaft
13. Bearing
14. Snap ring
15. Fan
16. Lock plates

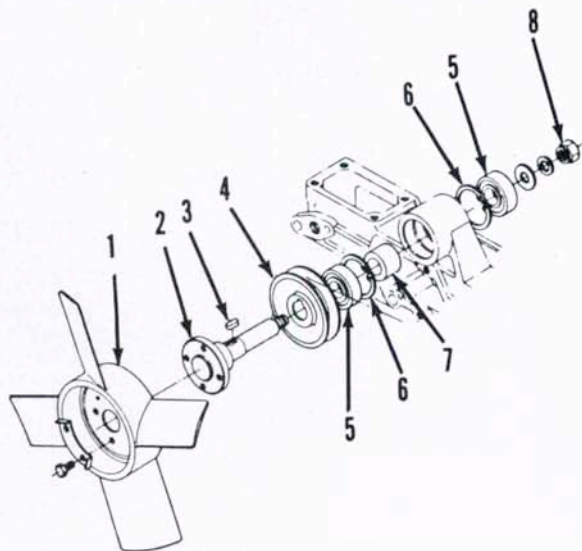

Fig. 67—Exploded view of cooling fan and shaft assembly used on Model L185.

1. Fan
2. Fan shaft
3. Key
4. Pulley
5. Bearing
6. Snap ring
7. Spacer
8. Nut

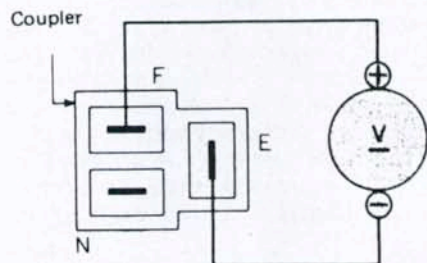

Fig. 68—Disconnect wiring connector from alternator and check battery voltage across connector terminals E and F.

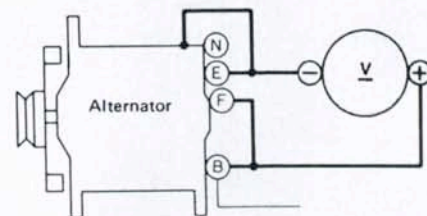

Fig. 69—Connect jumper wires and voltmeter to alternator as shown. Disconnect battery ground cable and turn off main switch during test so only alternator output voltage will be measured. Refer to text.

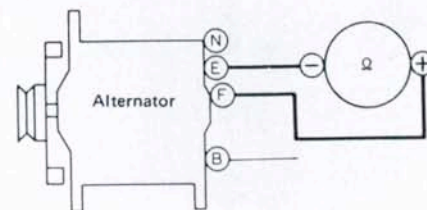

Fig. 70—Connect ohmmeter to E and F terminals of alternator to check resistance of rotor coil, slip ring and brush.

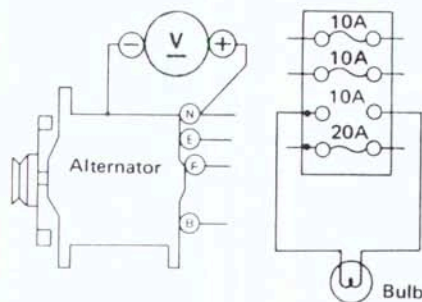

Fig. 71—To check regulator cut-in voltage, connect voltmeter to N terminal as shown and install a 30W bulb in place of 10A fuse.

terminal and ground (Fig. 71). Remove 10A fuse (connecting red wires) from fuse panel and connect a 30W bulb in its place. Start engine and increase speed until charge indicator lamp goes off or dims. At this point, voltage reading should be 4.5-5.8 volts. If cut-in voltage is too high, bend voltage relay adjusting arm (4—Fig. 72) closer to coil. If cut-in voltage is low, bend adjusting arm away from coil.

To check no-load regulating voltage, connect voltmeter across B terminal and ground (Fig. 73). Start engine and operate above 1300 rpm, then disconnect battery ground cable. Increase engine speed to obtain maximum

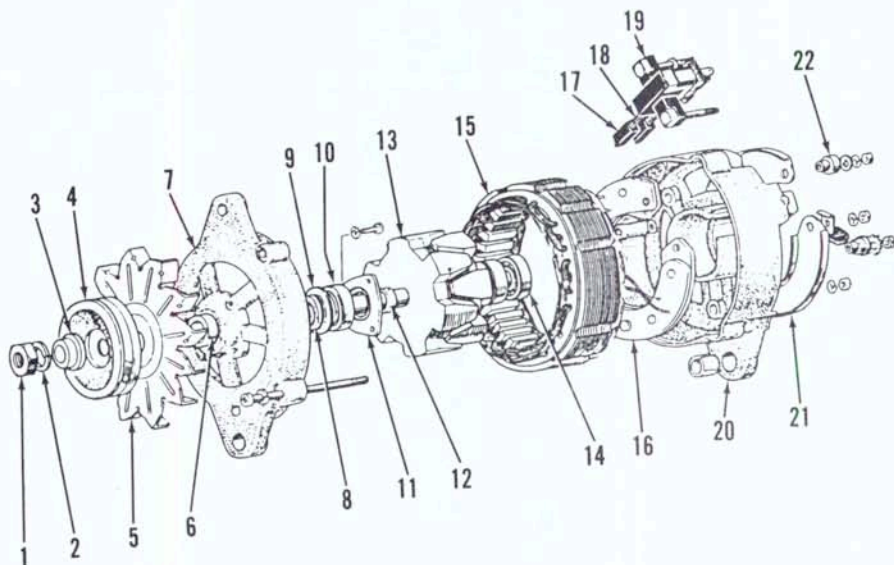

Fig. 74—Exploded view of typical alternator used on all models.

- | | | | |
|---------------|--------------------|-----------------|------------------|
| 1. Nut | 7. Front cover | 12. Spacer | 17. Brush |
| 2. Lockwasher | 8. Felt washer | 13. Rotor | 18. Brush spring |
| 3. Spacer | 9. Cover | 14. Bearing | 19. Brush holder |
| 4. Pulley | 10. Bearing | 15. Stator | 20. Housing |
| 5. Fan | 11. Retainer plate | 16. Diode plate | 21. End cover |
| 6. Spacer | | | 22. Insulator |

voltage reading. Regulated voltage should be between 13.8-14.8 volts. If voltage is too high, bend regulator adjusting arm (2—Fig. 72) closer to coil. If voltage is low, bend adjusting arm away from coil.

61. OVERHAUL. Refer to Fig. 74 for an exploded view of typical alternator unit. To disassemble alternator, first scribe match marks across frame halves

to ensure correct reassembly. Remove pulley nut (1), then remove pulley and fan. Remove through-bolts and separate drive end frame (7) and rotor (13). Remove rectifier retaining nuts and withdraw end cover (21), rectifier (16) and stator (15).

Use an ohmmeter to check rotor coil resistance across slip rings (Fig. 75). If resistance is not approximately 4.2 ohms, renew rotor. Check for continuity across slip ring to rotor frame (Fig. 76). There should not be continuity. Check stator coil leads (Fig. 77) for continuity and renew if open circuit is found. Check across stator leads and frame (Fig. 78) for continuity. Renew stator if grounded circuit is found. Check diodes by placing negative probe on outside diode pin and positive probe on mounting studs (Fig. 79), then reverse position of probes. Ohmmeter should indicate continuity in one direction and indicate infinity in the other direction if diode is satisfactory. Repeat test for each diode and renew

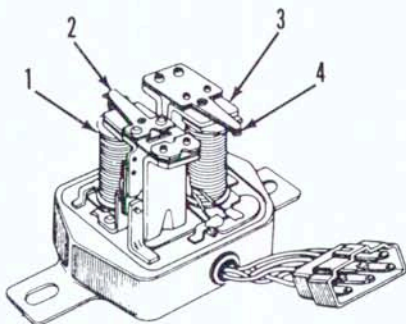

Fig. 72—Cut-in voltage can be adjusted by bending voltage relay adjusting arm (4). Bend voltage regulator adjusting arm (2) to adjust regulated voltage.

- | | |
|----------------------|------------------|
| 1. Voltage regulator | 3. Voltage relay |
| 2. Adjusting arm | 4. Adjusting arm |

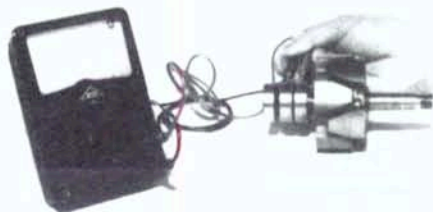

Fig. 75—Check resistance across rotor slip rings. Resistance should be approximately 4.2 ohms.

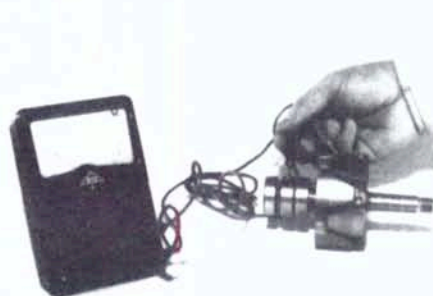

Fig. 76—Check for continuity (short circuit) between slip ring and rotor frame.



Fig. 77—Check stator coil leads for continuity.

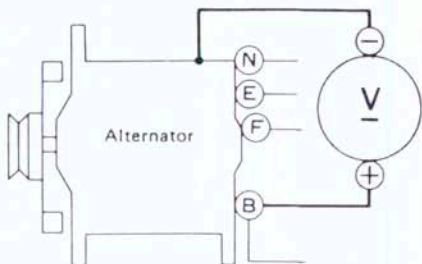

Fig. 73—Connect voltmeter across B terminal and ground to check no-load regulated voltage.

diode assembly if any are defective. Check for continuity between N terminal (1 - Fig. 80) and inside coil connecting terminals. If open circuit is found, renew diode assembly. If length of brushes is less than 10.5 mm (13/32 inch), renew brushes.

When reassembling alternator, be sure insulating washers are installed on positive diode holder studs (1 - Fig. 81). Before reinstalling rotor, insert a wire or plastic rod through hole in end frame (Fig. 82) to hold brushes up. Be sure to remove wire after rotor is installed.

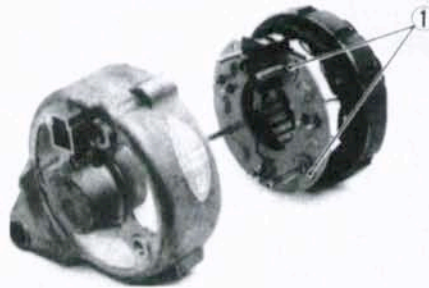

Fig. 81—Make certain insulating washers (1) are installed on positive diode mounting studs.

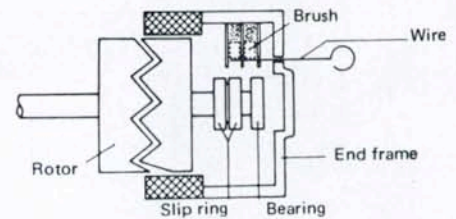

Fig. 82—Insert a wire or plastic rod through end frame to hold brushes up when reinstalling rotor.

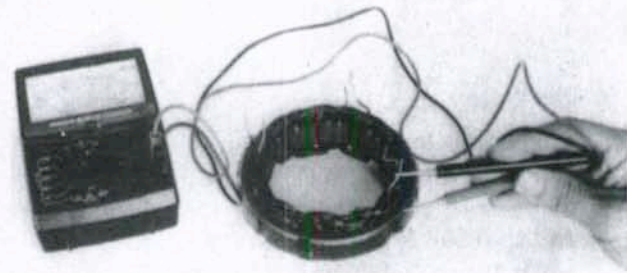

Fig. 78—Check for continuity (short circuit) across stator leads and stator frame.

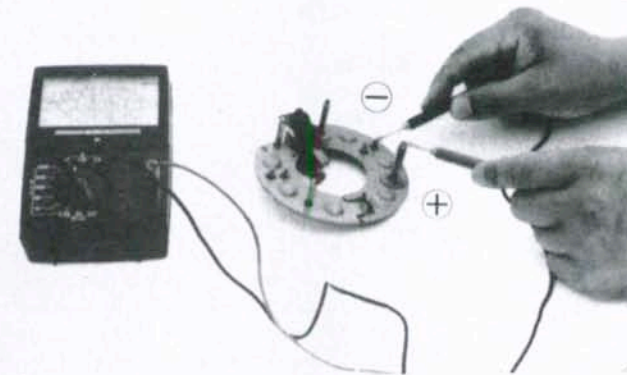

Fig. 79—Check diodes by placing negative probe on outside terminal and positive probe on mounting stud, then reverse test lead positions.

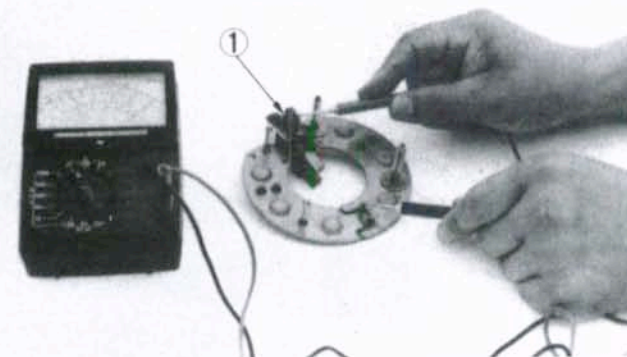

Fig. 80—There should be continuity between inside terminals and N terminal (1).

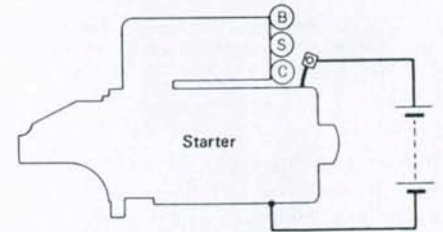

Fig. 83—Disconnect lead at C terminal of magnetic switch, then connect battery positive terminal directly to starter to check starter motor operation.

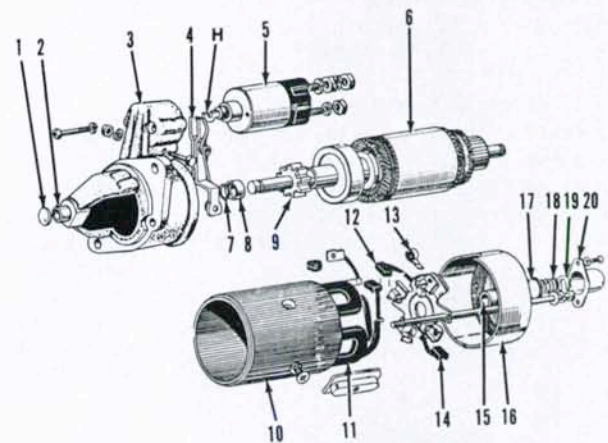

Fig. 84—Exploded view of starter motor used on Model L185.

- | | |
|-------------------------------|--------------------------|
| 1. Plug | 14. Brush & holder assy. |
| 2. Bushing | 15. Bushing |
| 3. Drive end frame | 16. End frame |
| 4. Drive lever | 17. Gasket |
| 5. Magnetic switch | 18. Spring |
| 6. Armature | 19. Retainer |
| 7. Snap ring | 20. Cap |
| 8. Spacer | |
| 9. Pinion gear & clutch assy. | |
| 10. Frame | |
| 11. Field coil | |
| 12. Brush | |
| 13. Brush spring | |

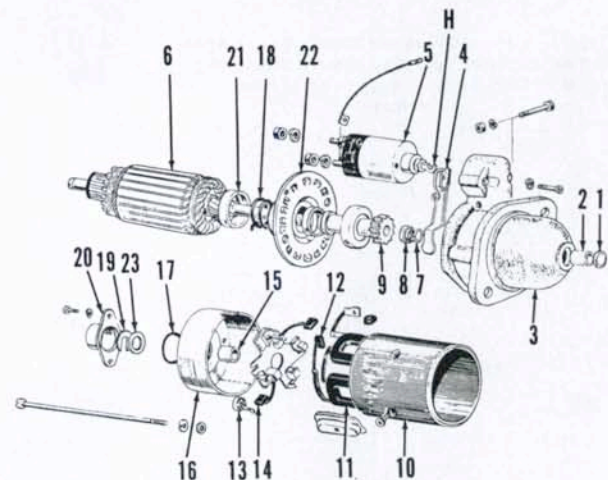

Fig. 85—Exploded view of starter used on Models L235, L245 and L275. Refer to Fig. 84 legend except for following items:

- | | | |
|-------------------|--------------------|------------|
| 21. Spring holder | 22. Center bearing | 23. Washer |
|-------------------|--------------------|------------|

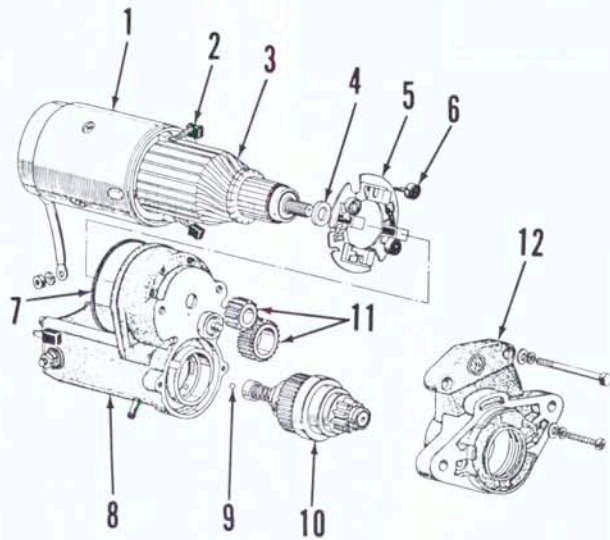

Fig. 86—Exploded view of starter used on Models L285, L295, L305, L345 and L355.

- 1. Frame
- 2. Brush
- 3. Armature
- 4. Gasket
- 5. Brush holder
- 6. Brush spring
- 7. Gasket
- 8. Magnetic switch assy.
- 9. Ball
- 10. Pinion gear & clutch assy.
- 11. Reduction gears
- 12. Drive end frame

Make certain match marks are aligned when assembling end frames.

STARTER MOTOR AND MAGNETIC SWITCH

All Models

62. To check starter and switch operation, disconnect lead from C terminal (Fig. 83) of magnetic switch and connect battery positive terminal directly to starter C lead. Connect battery negative terminal to starter frame. If motor runs smoothly, magnetic switch is defective; if not, motor is defective. Magnetic switch pull-in coil and hold-in coil should operate properly with 1/2 of rated voltage (six volts) applied to switch terminals. Renew magnetic switch as a unit if defective.

Refer to Fig. 84, 85 and 86 for exploded view of starter motors. When servicing starter motor, check armature and field coils for shorted or open circuits and renew as needed. Check armature bushings and bearings for excessive wear and renew as necessary. Minimum allowable brush length before renewal is

10.5 mm (0.4 inch) on Model L185 and 12.7 mm (0.5 inch) on all other models. Pinion engagement depth is set by adjusting magnetic switch hook (H—Fig. 84 or 85). With starter pinion in engaged position, distance between stop collar (8) and pinion should be 0.1-0.4 mm (0.004-0.016 inch) on Model L185 and 0.1-0.5 mm (0.004-0.020 inch) on Models L235, L245 and L275.

CLUTCH ADJUSTMENT

All Models

63. Clutch pedal free travel should be measured at top of pedal. Adjust length of clutch linkage rod (1—Fig. 91) as necessary to obtain following recommended free travel: 25-35 mm (1 to 1 3/8 inches) on all models except Models L235 and L275 with dual stage clutches which should be 30-40 mm (1-3/16 to 1-9/16 inches). On all models, make certain clutch releases completely after adjusting free travel and readjust if

necessary.

Adjust safety start switch (Fig. 91) to obtain recommended gap between switch and operating arm. On Model L355, clearance should be 2.0-3.0 mm (0.080-0.120 inch). On Models L235 and L275 with dual plate clutch, clearance should be 1.0-2.0 mm (0.040-0.080 inch). On all other models, clearance should be 0.5-1.0 mm (0.020-0.040 inch). Make certain starter will not operate until clutch pedal is fully depressed.

REMOVE AND REINSTALL

All Models

64. CLUTCH SPLIT. To separate (split) tractor between engine and clutch housing, proceed as follows: Remove muffler and hood. Disconnect battery cables. Drain oil from transmission housing, power steering reservoir (if so equipped) and engine oil. On models equipped with front-wheel drive, detach drive shaft. On all models, disconnect steering drag link and booster cylinder (if so equipped). Disconnect wiring as necessary at alternator, starter, glow plugs, safety switch, oil pressure switch and water temperature switch. Disconnect engine stop rod (if so equipped), throttle control rod, decompressor control cable, tractor meter cable and hydraulic tubing as needed. Shut off fuel and disconnect fuel supply pipe and fuel return pipe. Support engine and transmission with suitable splitting stands or overhead hoist. Remove engine mounting bolts, then separate engine from flywheel housing.

Reconnect tractor by reversing splitting procedure. Tightening retaining bolts to a torque of 50-56 N·m (37-41 ft.-lbs.)

OVERHAUL

Single Plate Clutch

65. Refer to Fig. 93 for an exploded view of single plate clutch assembly. Clutch cover and pressure plate (2) are available only as an assembly; all other components are available individually.

Check backlash between clutch disc and main shaft splines. Backlash should not exceed 2.0 mm (0.080 inch). Check clutch facing wear by measuring from clutch disc surface to top of rivet. If depth is less than 0.3 mm (0.012 inch), renew clutch disc. Renew clutch disc if it is warped, burned or oil soaked. Check pressure plate flatness using a straightedge and feeler gage. Plate should be flat within 0.2 mm (0.008 inch). Inspect release bearing for excessive wear or roughness when turned and renew as needed.

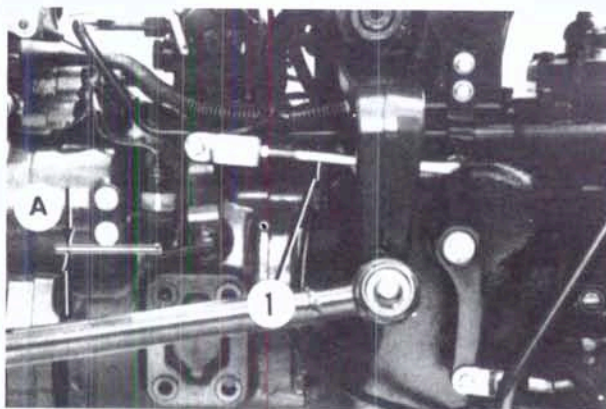

Fig. 91—Measure clutch pedal free travel at top of pedal. Adjust length of clutch rod (1) to obtain recommended free travel. Adjust safety start switch clearance (A) as necessary. Refer to text.

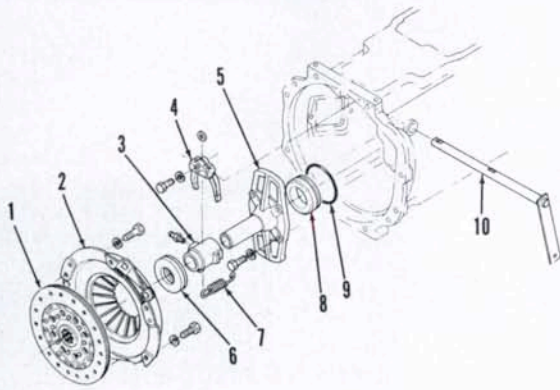

Fig. 93—Exploded view of single plate clutch assembly used on some models.

1. Clutch disc
2. Pressure plate assy.
3. Release sleeve
4. Fork
5. Case
6. Release bearing
7. Return spring
8. Spacer
9. "O" ring
10. Clutch shaft

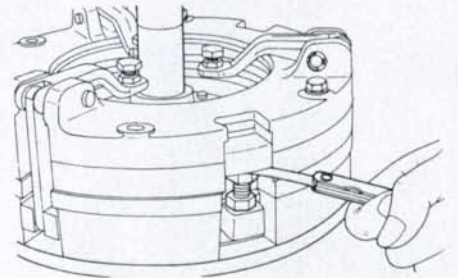

Fig. 95—Clearance between top of adjusting screw and pto pressure plate should be 1.0 mm (0.039 inch).

Dual Plate Clutch

66. An exploded view of dual plate clutch assembly used on some models is shown in Fig. 94. Before removing clutch assembly from flywheel, scribe match marks across clutch assembly and flywheel. Clutch assembly is dynamically balanced and should be reassembled in its original position.

To disassemble clutch, use a press or mount clutch on clutch tool (Code No. 07916-90050) to depress clutch cover and relieve spring tension on release levers. Remove release lever pivot pins, then separate clutch components.

Inspect all parts for excessive wear or other damage. Backlash between clutch

discs and transmission shaft splines should not exceed 2.0 mm (0.080 inch). Depth from clutch disc surface to top of rivet should not be less than 0.3 mm (0.012 inch). Renew clutch discs if warped, burned or oil soaked. Renew pressure plates if not flat within 0.2 mm (0.008 inch). Inspect release bearing for wear or roughness when turned and renew as necessary.

To reassemble clutch, mount clutch components on clutch alignment tool (Code No. 07916-90050) making certain match marks made prior to disassembly are aligned. Measure clearance between top of adjusting bolts (Fig. 95) and pto pressure plate with a feeler gage. Turn adjusting bolts as needed to obtain

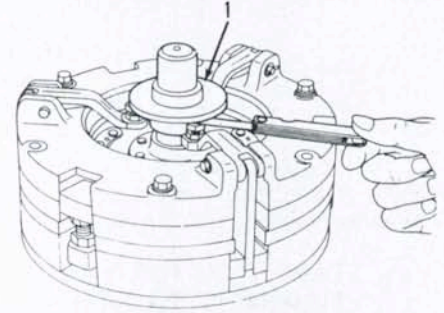

Fig. 96—Clearance between gage block (1) and release lever adjusting screws should be 0.3 mm (0.12 inch).

recommended clearance of 1.0 mm (0.039 inch). Position gage block (1—Fig. 96) onto clutch assembly tool. Adjust release lever bolts to obtain clearance of 0.3 mm (0.012 inch) between top of bolt and gage block.

Use clutch centering tool to align clutch discs and support clutch when reinstalling unit on flywheel. Tighten clutch mounting cap screws to a torque of 24-28 N·m (18-20 ft.-lbs.).

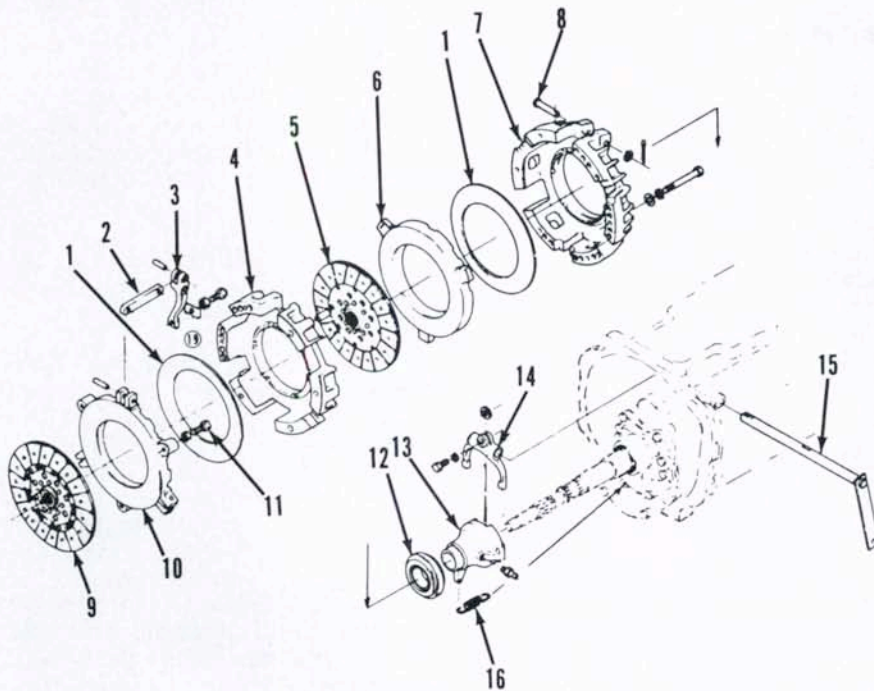

Fig. 94—Exploded view of dual plate clutch assembly used on some models.

- | | | |
|-----------------------|-----------------------------|---------------------|
| 1. Diaphragm springs | 7. Rear cover | 11. Adjusting bolt |
| 2. Release rod | 8. Pin | 12. Release bearing |
| 3. Release lever | 9. Traction clutch disc | 13. Hub |
| 4. Front cover | 10. Traction pressure plate | 14. Fork |
| 5. Pto clutch disc | | 15. Clutch shaft |
| 6. Pto pressure plate | | 16. Return spring |

**TRANSMISSION
(Models
L185-L245-
L285-L295-L305-
L345)**

67. A four-speed sliding gear main transmission unit is combined with a high-low range transmission to provide eight forward speeds and two reverse speeds.

SHIFTER RAILS AND FORKS

Models L185-L245-L285-L295

68. **R&R AND OVERHAUL.** Shift rails, forks and associated parts are shown in Fig. 97. Models L185, L245 and L295 are equipped with three speed

pto and use two pto shift forks (26). Model L285 is equipped with two speed pto and uses a single pto shift fork.

To disassemble main transmission shift mechanism, first unbolt and remove lever housing (9) and remove lever (1) and pto shift lever (2). Main shift rail detent springs (12) and balls (13). Main shift lever (2) and pto shift lever (1) are withdrawn from below after removing lever knob, snap ring (3), washers and spring (5). Positioning pins (10) can be punched out and renewed if worn or damaged.

With shift housing removed, drive spring pins (20) down out of shift forks. Bump shift rails rearward out of housing. Note that interlock balls (14) occupy

a cross drilling between rails. When one rail is moved from neutral, balls enter grooves in adjoining rails, thus locking rails and preventing shift forks from moving into two gears at one time. A suggested method of disassembly is to remove center rail first, then dump both interlock balls out through hole where center rail was removed. Make certain interlock balls are reinstalled when shift housing is reassembled.

To remove range shift fork (39) and rail (40), tractor must be split between front and rear transmission housings and hydraulic lift housing must be removed. Remove retaining set screw (41) and snap pin, then push pin rail

rearward catching detent ball and spring as rail is removed. Drive out spring pin and remove plate (34) to disassemble shift lever (33) and arm (36).

To reinstall shift mechanism, remove lever housing (9) if not already done. Position all shift forks and sliding gears to neutral position. Hold main shift forks together to hold neutral stops (18) in position, then carefully install shift cover making sure each fork correctly meshes with its respective slot in sliding gears and pto levers (30) engage pins (29) in pto shift forks. Tighten shift housing retaining screws, then move all shift forks to be sure they operate properly. Install lever cover guiding ends of

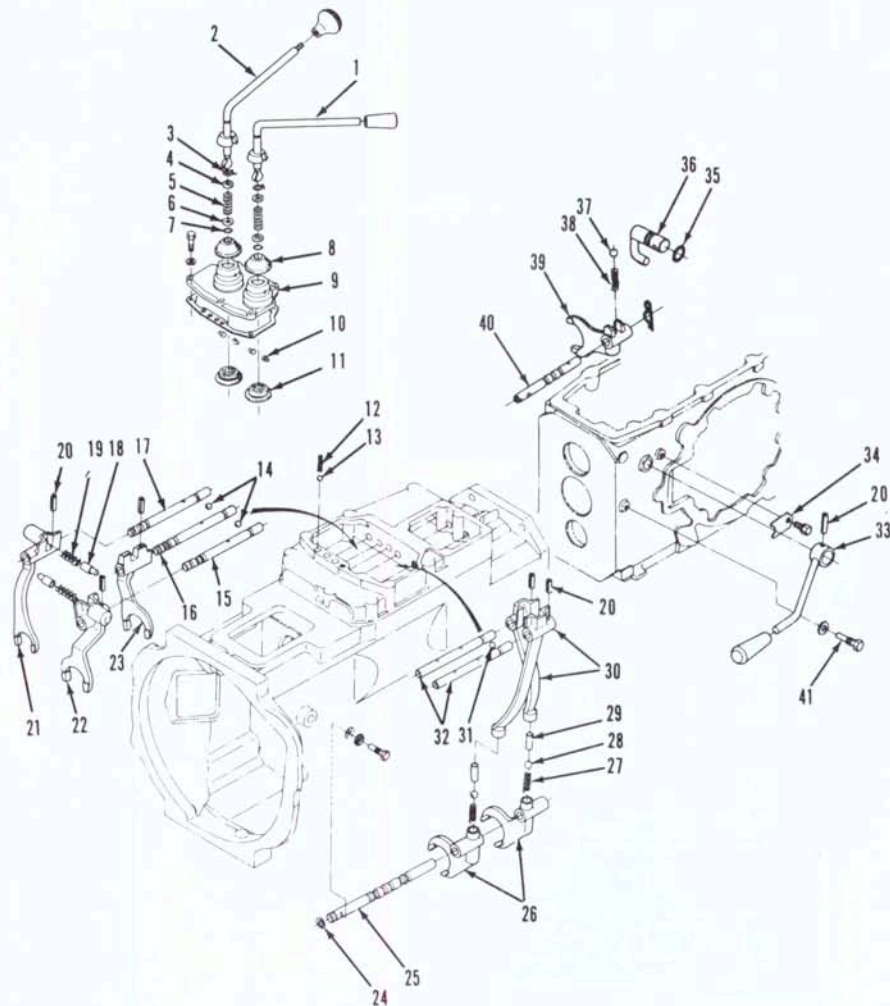

Fig. 97—Exploded view of transmission shift rails and forks used on Models L185, L245 and L295. Models L285, L305 and L345 are similar except a single pto shift fork is used.

- | | | |
|---------------------|-----------------------|------------------------|
| 1. Pto shift lever | 15. Shift rail | 28. Ball |
| 2. Main shift lever | 16. Shift rail | 29. Pin |
| 3. Snap ring | 17. Shift rail | 30. Shift levers (pto) |
| 4. Washer | 18. Neutral stop | 31. Interlock ball |
| 5. Spring | 19. Spring | 32. Shift rails (pto) |
| 6. Washer | 20. Spring pin | 33. Range shift lever |
| 7. "O" ring | 21. Shift fork | 34. Stop plate |
| 8. Shield | 22. Shift fork | 35. "O" ring |
| 9. Housing | 23. Shift fork | 36. Shift arm |
| 10. Pins | 24. "O" ring | 37. Ball |
| 11. Oil shield | 25. Fork shaft | 38. Spring |
| 12. Spring | 26. Shift forks (pto) | 39. Shift fork |
| 13. Detent ball | 27. Spring | 40. Shift rail |
| 14. Interlock balls | | 41. Set screw |

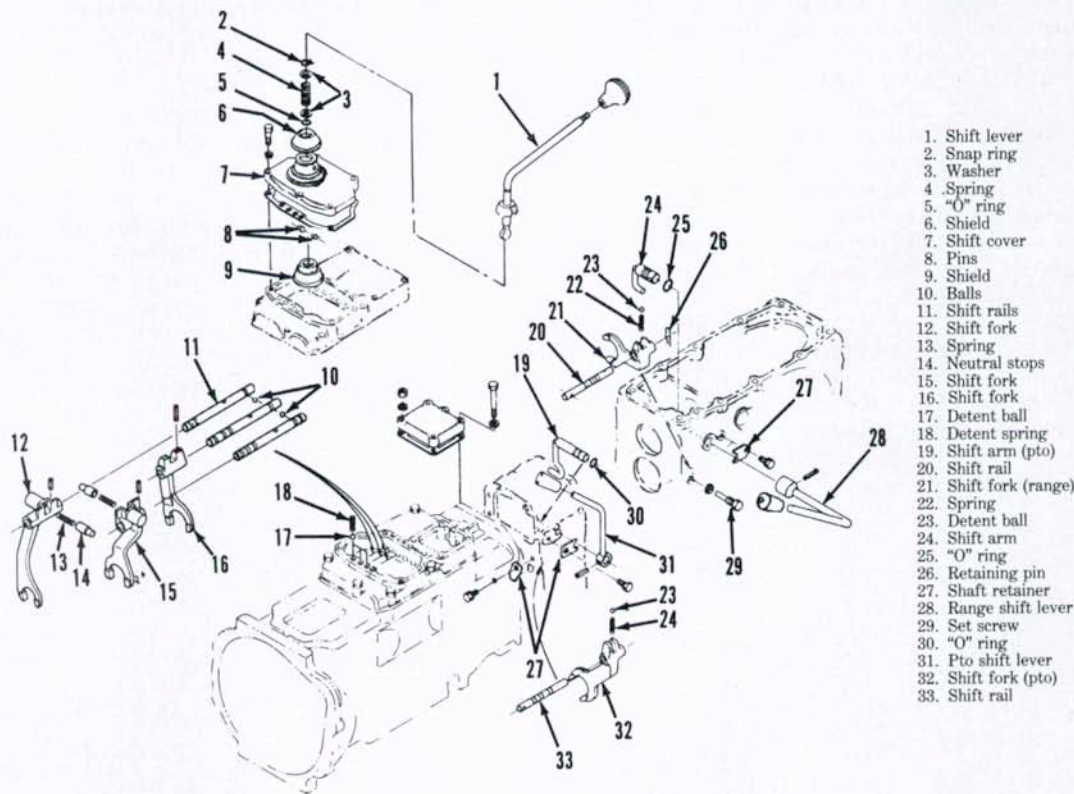

Fig. 98—Exploded view of shifter forks and shafts used on Models L305 and L345.

levers into proper position as cover is lowered onto shift cover.

Models L305-L345

69. R&R AND OVERHAUL. Refer to Fig. 98 for an exploded view of shift rails, forks and associated parts.

To disassemble main shift housing, unbolt and remove lever cover (7) and dump out detent springs (18) and balls (17). Remove shift lever knob and unseat spring retaining ring (2), then lower shift lever (1) out bottom of cover. Positioning pins (8) can be punched out and renewed if worn or damaged. Drive spring pins out of shift forks. Rails (11) are removed rearward out of cover. A suggested method of disassembly is to remove center rail first, dump both interlock balls (10) out through hole where center rail was removed, then remove outer rails. Be sure interlock balls are reinstalled when cover is reassembled.

To remove pto shift fork (32), tractor must be split between front and rear transmission housings. Remove retainer (27) and remove shift rail (33) out front of center case.

To remove range shift fork (21), rockshaft housing and differential assembly must be removed as outlined in paragraph 91. Remove set screw (29) and retaining pin (26), then pull rail (20) rearward and withdraw shift fork.

To reassemble shift assemblies, reverse the disassembly procedure. To reinstall shift housing, position shift forks and sliding gears in neutral position. Carefully install shift housing making sure each fork correctly meshes with its respective slot in sliding gear. Tighten housing mounting cap screws, then move all shift forks to be sure they operate correctly.

FRONT TRANSMISSION

All Models

70. REMOVE AND REINSTALL.

To remove front transmission housing, first split tractor between engine and clutch housing as outlined in paragraph 64. Support front transmission housing and rear transmission housing separately. Remove steering wheel, instrument panel, fuel tank and steering gear assembly. Remove steps and brake and clutch pedal assemblies. Disconnect hydraulic pipes from lift cylinder and transmission housing. Disconnect wiring harness as needed. Remove transmission mounting stud nuts, then separate front transmission from rear housing.

When reconnecting transmission, be sure couplings are installed on transmission and pto shafts. Tighten mounting stud nuts to a torque of 47-56 N·m (35-40 ft.-lbs.) and complete installation

by reversing removal procedure.

Models L185-L245-L295

71. OVERHAUL. To disassemble main transmission, remove shift housing and forks. Remove clutch release bearing, fork and shaft, then unbolt and remove front oil seal retainer. Remove retaining rings from countershaft (14—Fig. 99 or 100), then tap shaft forward until front bearing is out of housing. Remove bearing retaining ring, then remove front bearing using a suitable puller. Tap countershaft rearward and withdraw gears as shaft is removed. Use a brass drift to tap input shaft (26) and bearings forward out of housing. Remove bearings and gears from shaft as necessary. Remove set screw (2) retaining reverse idler shaft (1), then withdraw shaft and gear. Remove set screw securing pto shift fork shaft, then tap shaft forward and remove shift fork. Tap pto countershaft (37—Fig. 99 or 41—Fig. 100) forward until front bearing is out of housing. Use a suitable puller to remove front bearing, then tap shaft rearward and withdraw gears and pto drive one-way clutch assembly.

To reassemble transmission, reverse the disassembly procedure while observing the following items. Be sure thrust washers are reinstalled with their

grooves facing the gears. Make certain set screw indentation in pto shift fork shaft and reverse idler shaft are positioned correctly. Grease lip of input shaft oil seal before reinstalling.

Model L285

72. OVERHAUL. To disassemble main transmission, proceed as follows: Remove shift housing and forks.

Remove clutch release bearing, fork and shaft, then unbolt and remove input shaft seal retainer. Tap countershaft (11—Fig. 101) forward and remove cover (6) and snap ring (7). Tap shaft rearward and withdraw gears as shaft is removed from housing. Tap input shaft assembly (17) forward and remove from housing. Remove bearings and gear as necessary. Remove retainer plate (1), then withdraw reverse idler shaft (3) and gear (5). Tap pto countershaft (24)

forward and remove cover (20), snap ring and front bearing. Tap shaft rearward out of housing and withdraw gears (23) and overrunning clutch assembly (26 through 33).

Inspect all gears and shafts for excessive wear, chipped or cracked teeth or other damage and renew as necessary.

To reassemble main transmission, reverse the disassembly procedure.

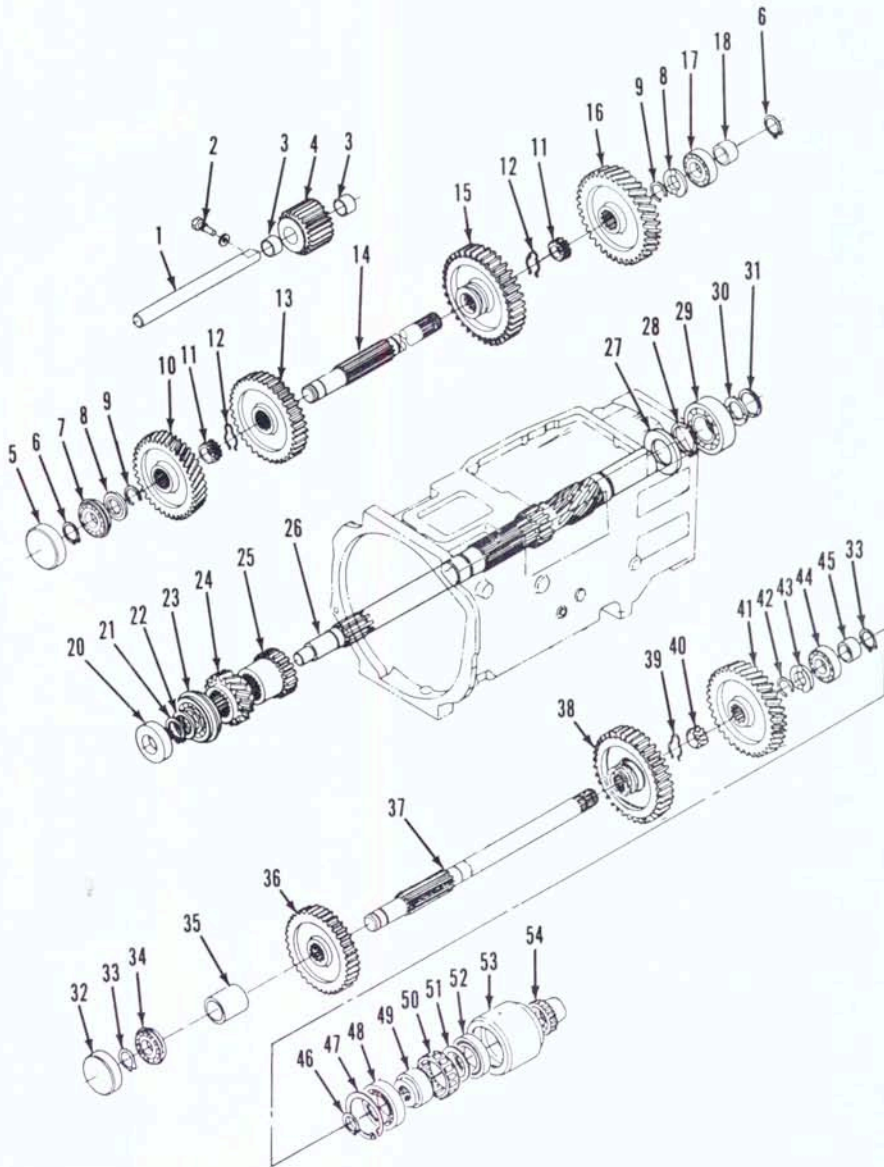

Fig. 99—Exploded view of gears and shafts located in front transmission housing on Models L185 and L245.

- | | | | |
|------------------------|-----------------|----------------------|---------------------|
| 1. Reverse idler shaft | 15. Gear (45T) | 28. Snap ring | 41. Gear (45T) |
| 2. Set screw | 16. Gear (45T) | 29. Bearing | 42. Retaining ring |
| 3. Bushings | 17. Bearing | 30. Thrust washer | 43. Thrust washer |
| 4. Reverse idler gear | 18. Spacer | 31. Snap ring | 44. Bearing |
| 5. Cover | 20. Oil seal | 32. Cover | 45. Spacer |
| 6. Snap ring | 21. Snap ring | 33. Snap ring | 46. Snap ring |
| 7. Bearing | 22. Washer | 34. Bearing | 47. Snap ring |
| 8. Thrust washer | 23. Bearing | 35. Spacer | 48. Bearing |
| 9. Retaining ring | 24. Gear (23T) | 36. Gear (41T) | 49. Coupling |
| 10. Gear (32T) | 25. Gear (17T) | 37. Pto countershaft | 50. Pto clutch cams |
| 11. Spline boss | 26. Input shaft | 38. Gear (45T) | 51. Snap ring |
| 12. Retainer clip | 27. Spacer | 39. Retainer clip | 52. Spacer |
| 13. Gear (41T) | | 40. Spline boss | 53. Clutch case |
| 14. Countershaft | | | 54. Coupling |

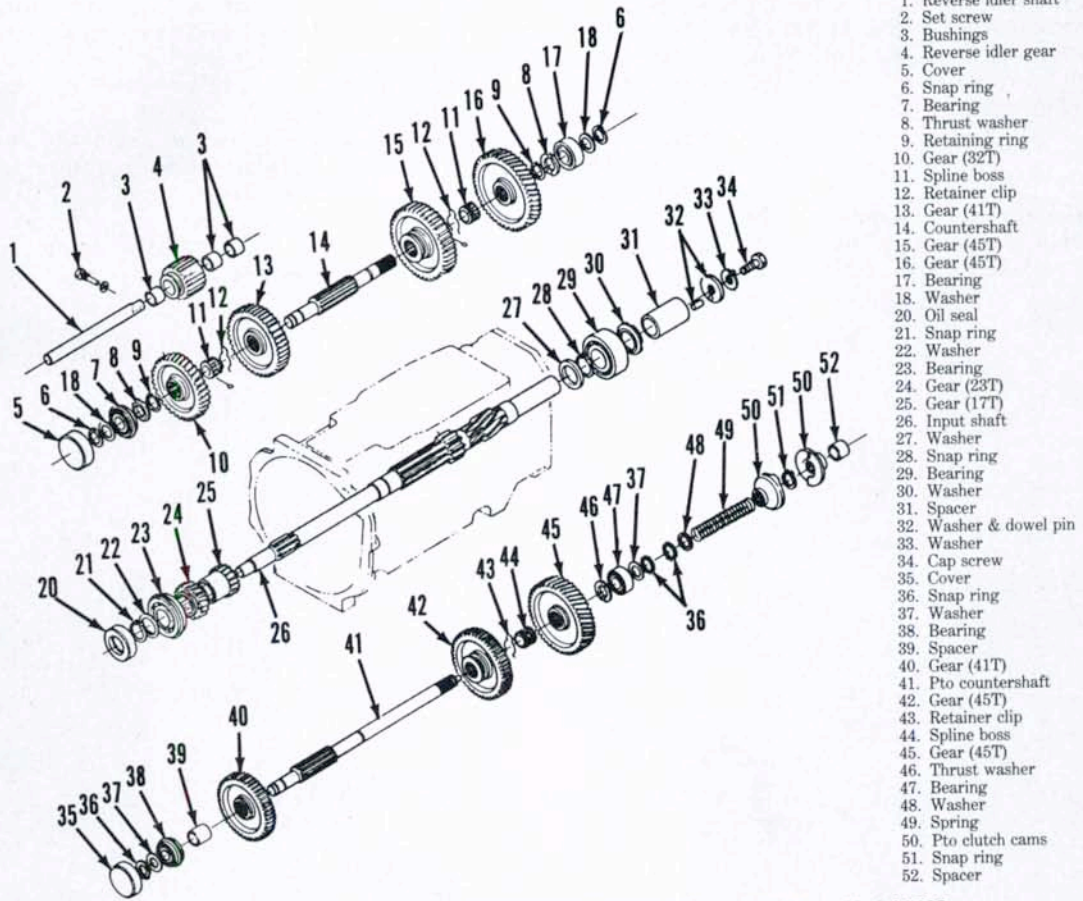

Fig. 100—Exploded view of gears and shafts located in front transmission housing on Model L295.

1. Reverse idler shaft
2. Set screw
3. Bushings
4. Reverse idler gear
5. Cover
6. Snap ring
7. Bearing
8. Thrust washer
9. Retaining ring
10. Gear (32T)
11. Spline boss
12. Retainer clip
13. Gear (41T)
14. Countershaft
15. Gear (45T)
16. Gear (45T)
17. Bearing
18. Washer
20. Oil seal
21. Snap ring
22. Washer
23. Bearing
24. Gear (23T)
25. Gear (17T)
26. Input shaft
27. Washer
28. Snap ring
29. Bearing
30. Washer
31. Spacer
32. Washer & dowel pin
33. Washer
34. Cap screw
35. Cover
36. Snap ring
37. Washer
38. Bearing
39. Spacer
40. Gear (41T)
41. Pto countershaft
42. Gear (45T)
43. Retainer clip
44. Spline boss
45. Gear (45T)
46. Thrust washer
47. Bearing
48. Washer
49. Spring
50. Pto clutch cams
51. Snap ring
52. Spacer

Models L305-L345

73. **OVERHAUL.** To disassemble main transmission, first remove shift housing and forks if not already removed. Remove clutch release bearing, fork and shaft. Remove mounting cap screws from front cover (25—Fig. 102), then use two jackscrews to lift off cover and input shaft (28) as a unit. Remove snap ring and pto drive gear (51), then unbolt and pull gear case (1) with spacers (3 and 55) from housing. Remove clips (11) and retaining rings from countershaft (13), then slide coupling (17) rearward until disengaged from countershaft. Use a suitable puller to remove front bearing (6), then lift countershaft and gears from housing. Remove center case from front transmission housing. Remove set screw (22) and withdraw reverse idler shaft (21) and gear (24). Screw two bolts into mainshaft spacer (29) and pull spacer from housing. Remove retaining ring securing front bearing (34), then tap mainshaft (44) rearward out of housing. Tap pto countershaft (60) to the rear and remove shaft, gear and washers. Needle bearings (58) can be driven out and renewed if worn or damaged.

Fig. 101—Exploded view of gears and shafts located in front transmission housing Model L285.

1. Retainer plate
2. "O" ring
3. Idler shaft
4. Bushings
5. Reverse idler gear
6. Cover
7. Snap ring
8. Bearing
9. Gears (23-36T)
10. Gears (33-38T)
11. Countershaft
12. Bearing
13. Coupling
14. Oil seal
15. Washer
16. Bearing
17. Input shaft
18. Gear (19T)
19. Bearing
20. Cover
21. Snap ring
22. Bearing
23. Gears (33-38T)
24. Pto countershaft
25. Bearing
26. Snap ring
27. Bearing
28. Coupling
29. Sprag clutch
30. Spacer
31. Bearing
32. Clutch case
33. Coupling
34. Shaft
35. Bearing

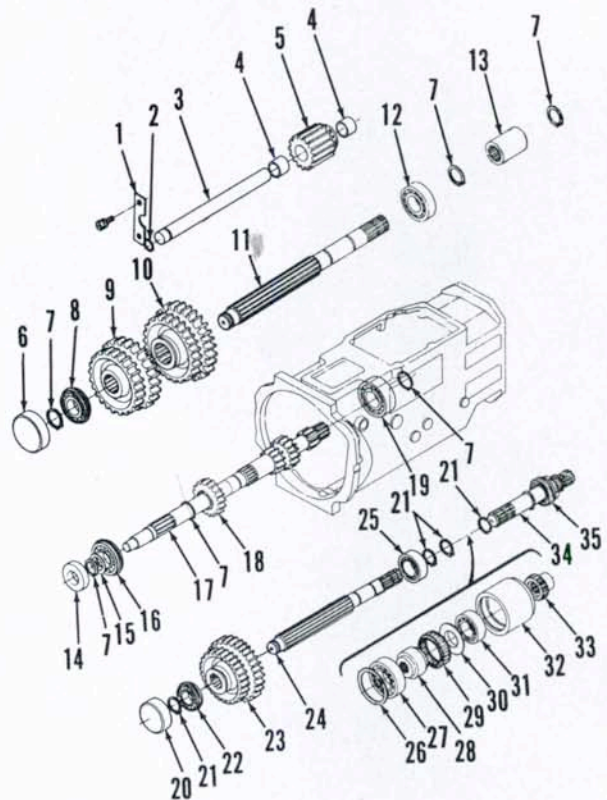

To disassemble center case, tap shaft (19) forward to remove bearing and shaft from case. Remove snap ring, gear (35) and spacer (36) from center shaft, then tap shaft out of case. Remove retainers (27—Fig. 98), then drive spring pin out of pto shift lever (31). Remove arm (19), shift rail (33) and fork (32). Remove retaining ring from rear of countershaft (63—Fig. 102), then tap shaft forward out of case.

To reassemble main transmission, reverse the disassembly procedure.

REAR TRANSMISSION HOUSING

All Models

74. REMOVE AND REINSTALL.

To remove rear housing, first drain oil from transmission housings and rear axle housings. Remove hydraulic pressure

and intake pipes leading to pump. Disconnect electrical wiring and brake control rods. Wedge front axle to prevent unit from tipping and support tractor under front transmission housing. Support rear housing with a suitable hoist or stand, then remove fenders, rear wheels and final drive units as outlined in paragraph 100. Remove seat and rockshaft housing, then separate housing from tractor.

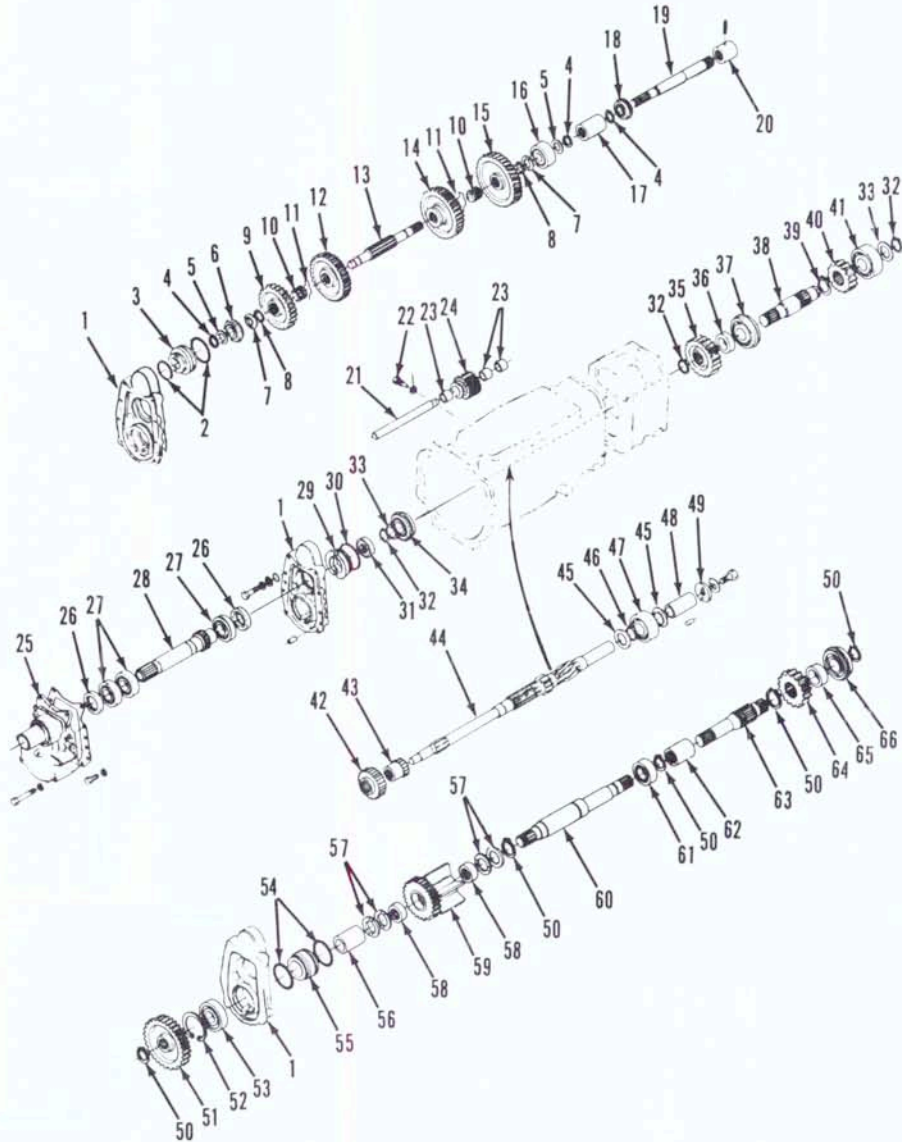

Fig. 102—Exploded view of gears and shafts located in front and center transmission housings on Models L305 and L345. Fan brake on gear (59) was used on early models only.

- | | | | |
|-------------------|------------------------|----------------|------------------------|
| 1. Gearcase | 18. Bearing | 34. Bearing | 50. Snap ring |
| 2. "O" rings | 19. Shaft | 35. Gear (21T) | 51. Gear (39T) |
| 3. Spacer | 20. Coupling | 36. Spacer | 52. Snap ring |
| 4. Snap ring | 21. Idler shaft | 37. Bearing | 53. Bearing |
| 5. Washer | 22. Set screw | 38. Shaft | 54. "O" rings |
| 6. Bearing | 23. Bushing | 39. Snap ring | 55. Spacer |
| 7. Thrust washer | 24. Reverse idler gear | 40. Gear (15T) | 56. Spacer |
| 8. Retaining ring | 25. Front cover | 41. Bearing | 57. Thrust washers |
| 9. Gear (30T) | 26. Oil seal | 42. Gear | 58. Needle bearings |
| 10. Spline boss | 27. Bearings | 43. Gear | 59. Gear |
| 11. Retainer clip | 28. Input shaft (pto) | 44. Main shaft | 60. Countershaft (pto) |
| 12. Gear (41T) | 29. Spacer | 45. Washer | 61. Bearing |
| 13. Countershaft | 30. "O" ring | 46. Snap ring | 62. Coupling |
| 14. Gear (45T) | 31. Oil seal (L305) | 47. Bearing | 63. Shaft |
| 15. Gear (45T) | 32. Snap ring | 48. Spacer | 64. Gear (16T) |
| 16. Bearing | 33. Washer | 49. Washer | 65. Spacer |
| 17. Coupling | | | 66. Bearing |

When reinstalling rear transmission housing, make sure shaft couplings are installed. Tighten mounting stud nuts to a torque of 47-56 N·m (35-40 ft.-lbs.) and rockshaft housing. Remove stud nuts securing rear housing, then separate housing from tractor.

Models L185-L245-L295

75. OVERHAUL. To disassemble rear transmission housing, tap countershaft (4—Fig. 103 or 104) forward until front bearing is out of housing. Tilt rear of shaft upward for working clearance, then remove rear bearing using a suitable puller. Withdraw shaft and gear (6) from housing. Insert a brass rod to lock differential ring gear, then remove locknut (9) from bevel pinion shaft (18). Remove differential lock, bearing cases and differential assembly from housing. Remove set screw retaining range shift fork shaft. Pull shaft rearward and remove shift fork. Use a suitable puller to remove front bearing case (13) and bearings from bevel pinion shaft. Be sure to retain shims (14) for use in reassembly. Pull pinion shaft rearward from housing and withdraw gears (15). Remove retaining ring and press shaft out of rear bearings (17) if renewal is necessary. Remove pto shaft front bearing retainer and cap screws securing rear bearing case (28—Fig. 103 or 34—Fig. 104). Tap pto output shaft (21 or 32) rearward out of housing. Remove locknut (23 or 27) and bearing retaining ring, then press rear bearing and case off pto shaft. Drive oil seal (26 or 30) out of bearing case

Bevel pinion shaft (18) is available only as a matched set with bevel ring gear. If renewing shaft or bearings, backlash and mesh position must be checked and adjusted when reassembling. Refer to paragraphs 95 and 96 for procedure.

To reassemble rear transmission, reverse the disassembly procedure. Tighten bevel pinion shaft locknut to a torque of 150-195 N·m (110-148 ft.-lbs.).

Model L285

76. OVERHAUL. To disassemble rear transmission housing, proceed as follows: Remove rear snap ring from range countershaft (3—Fig. 105), then tap shaft forward out of housing and remove gear (4). Inset a brass drift into differential ring gear teeth to prevent bevel pinion shaft (14) from turning, then remove locknut (9). Remove differential assembly as outlined in paragraph 91. Remove front bearing case mounting cap screws, then tap bevel pinion shaft rearward and remove shaft and gear (11) from housing. Remove snap ring and press pinion shaft

Fig. 103—Exploded view of gears and shafts located in rear transmission housing on Models L185 and L245.

1. Coupling
2. Snap ring
3. Bearing
4. Countershaft
5. Snap ring
6. Gear (31T)
7. Spacer
8. Bearing
9. Nut
10. Cover
11. Spacer
12. Bearings
13. Bearing case
14. Shim
15. Gear (29-48T)
16. Snap ring
17. Bearing
18. Bevel pinion shaft
19. Spacer
20. Bearing
21. Pto shaft
22. Bearing retainer
23. Nut
24. Snap ring
25. Bearing
26. Oil seal
27. Gasket
28. Bearing case
29. Slinger
30. Cap

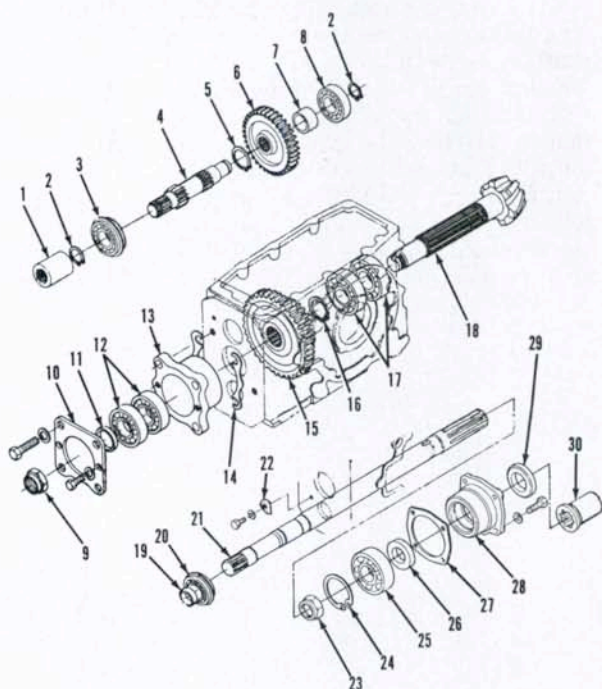

out of rear bearings (13). Be sure to retain shims (8) for use in reassembly. Remove snap ring from front of pto output shaft (18). Remove cap screws from bearing case (25), then tap pto shaft rearward from housing. Remove nut (19) and snap ring (20), then press shaft out of bearing (21) and case. Drive oil

seal (23) out of case.

Inspect all parts for excessive wear or other damage and renew as necessary. Bevel pinion shaft (14) is available only as a matched set with bevel ring gear. If shaft or bearings are being renewed, backlash and gear mesh must be checked and adjusted when reassembling as

Fig. 104—Exploded view of gears and shafts located in rear transmission on Model L295.

1. Coupler
2. Snap ring
3. Bearing
4. Countershaft
5. Snap ring
6. Gear (21T)
7. Spacer
8. Bearing
9. Nut
10. Cover
12. Bearing
13. Bearing case
14. Shim
15. Gear (15-37T)
16. Snap ring
17. Bearings
18. Bevel pinion shaft
19. Coupler
20. Snap ring
21. Bearing
22. Shaft
23. Snap rings
24. Bearing
25. Shaft
26. Coupler
27. Nut
28. Snap ring
29. Bearing
30. Oil seal
31. Sleeve
32. Pto shaft
33. Gasket
34. Bearing case
35. Slinger
36. Cap

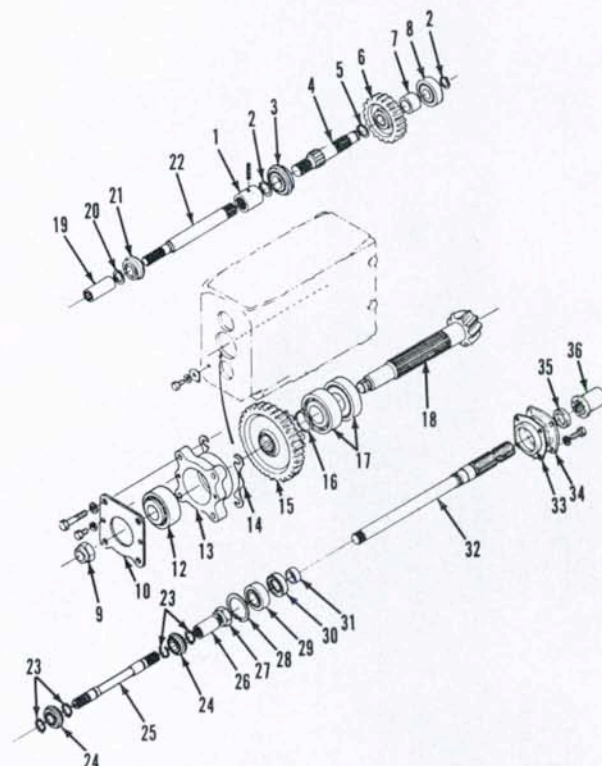

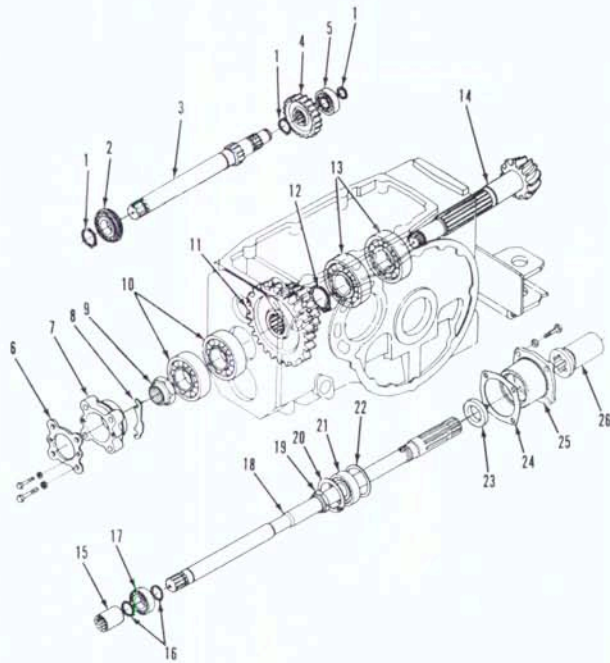

Fig. 105—Exploded view of gears and shafts located in rear transmission housing on Model L285.

1. Snap ring
2. Bearing
3. Reverse idler shaft
4. Reverse idler gear
5. Bearing
6. Cover
7. Bearing case
8. Shim
9. Nut
10. Bearings
11. Gears (26-46T)
12. Snap ring
13. Bearings
14. Bevel pinion shaft
15. Coupler
16. Snap ring
17. Bearing
18. Pto output shaft
19. Nut
20. Snap ring
21. Bearing
22. Spacer
23. Oil seal
24. Gasket
25. Bearing case
26. Cap

outlined in paragraphs 95 and 96.

To reassemble rear transmission housing, reverse the disassembly procedure. Be sure original shim pack (8) is reinstalled if original bevel pinion shaft and bearings are being reinstalled. Tighten locknut (9) to a torque of 150-195 N·m (110-145 ft.-lbs.). Stake nut after tightening.

Models L305-L345

77. OVERHAUL. To disassemble rear transmission housing, proceed as follows: Remove differential lock actuator shaft and shift fork. Remove snap ring from rear of countershaft (3—Fig. 106), then tap shaft forward from housing and remove gear (4) and bearings. Insert a brass rod between ring gear and bevel pinion gear to prevent shaft from turning, then remove nut (7) from bevel pinion shaft (15). Remove differential carrier bearing cases and withdraw differential assembly. Loosen set screw securing range shift rail (20—Fig. 98), remove snap pin (26) and pull rail forward out of housing and withdraw fork (21). Remove shift lever (28) and arm (24). Remove cap screws securing bevel pinion bearing case (10—Fig. 106). Tap bevel pinion shaft rearward out of housing, then remove front bearing case and bearing. Be sure to retain shims (11) for use in reassembly. Remove snap ring (13) and press shaft out of bearings (14). To remove pto output shaft (26), remove front bearing (17) using a suitable puller. Remove bearing case (28) mounting cap screws, then withdraw shaft assembly rearward from transmission housing. Remove nut (20) and retaining ring (21), then press shaft out of bearing case.

Inspect all parts for excessive wear or other damage and renew as necessary. Bevel pinion shaft (15) is available only as a matched set with bevel ring gear. If renewing shaft or bearings, backlash and gear mesh must be checked and adjusted when reassembling as outlined in paragraphs 95 and 96.

To reassemble rear transmission housing, reverse the disassembly procedure.

Tighten pto shaft locknut (20) to a torque of 150-195 N·m (110-145 in.-lbs.) Stake nut after tightening. Tighten bevel pinion shaft nut to a torque of 150-195 N·m (110-145 ft.-lbs.), then stake nut.

TRANSMISSION (Models L235-L275-L355)

78. On all models, a four-speed main transmission unit is coupled with high-low range transmission to provide eight forward speeds. Models L235 and L275, a mechanical shuttle (forward-reverse) section allows forward operation in any of the eight speeds and reverse operation in first seven speeds. Eighth speed is locked out in reverse for safety reasons.

On Model L355, a hydraulically actuated forward-reverse shuttle transmission allows forward or reverse operation in any of the eight speeds.

SHIFTER RAILS AND FORKS

Models L235-L275

79. R&R AND OVERHAUL. Shift rails, forks and associated parts are shown in Fig. 107. Pto shift components are covered in paragraph 110.

Fig. 106—Exploded view of gears and shafts located in rear transmission housing on Models L305 and L345.

1. Snap ring
2. Bearing
3. Countershaft (range)
4. Gear (21T)
5. Spacer
6. Bearing
7. Nut
8. Cover
9. Bearing
10. Bearing case
11. Shim
12. Gear (15-37T)
13. Snap ring
14. Bearings
15. Bevel pinion shaft
16. Gear (22T)
17. Bearing
18. Snap ring
19. Bearing
20. Nut
21. Snap ring
22. Spacer (L305)
23. Bearing
24. Oil seal
25. Sleeve
26. Pto output shaft
27. Gasket
28. Bearing case
29. Slinger
30. Cap

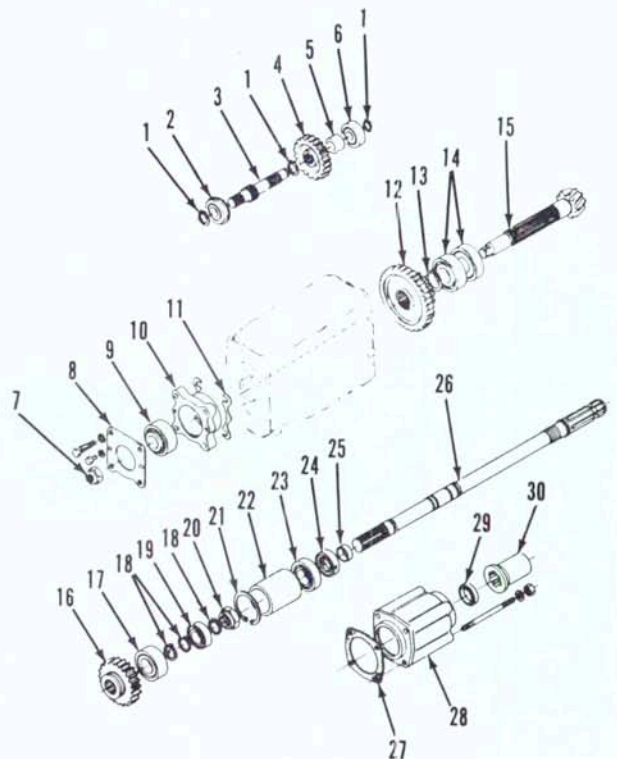

To remove main shift housing (10), disconnect shift lockout control cable and remove shift lever guide housing. Shift transmission into neutral, then unbolt and remove housing with shift rails and forks.

To disassemble main shift housing, remove shift cover with shift levers. Remove retaining ring (3), then withdraw shift lever from bottom of shift cover. Remove detent balls (16) and springs. Drive spring pins out of shift forks (11 and 12) and remove shift rails (13) rearward from housing. Drive spring pins out of holder (17) and shuttle shift lever (19). Remove shift rail (18), holder and lever.

To remove shuttle shift fork (21) or range shift fork (27), tractor must be split between front transmission housing and rear transmission housing. Rockshaft housing must also be removed from rear transmission housing for access to range shift fork. Loosen set

screw (23) and remove snap pin (32). Pull shift rail (26) forward and remove shift fork. Remove retainer (25) and drive shift pin from shift lever. Remove shift lever (24) and arm (28). To remove shuttle shift fork, remove center case from front transmission housing. Drive spring pin out of fork (21), then pull rail (20) out of housing and remove fork.

To reinstall shift linkage, reverse the removal procedure. Adjust shift lever lockout cable (4—Fig. 108) as follows: Place range shift lever (5) in high speed position and shuttle lever (2) in reverse position. Push down lightly on lockout lever (1) and move main speed shift lever (3) to neutral position and to the right. There should be a gap (A) of 1-2 mm (3/64-5/64 inch) between lockout lever and shift lever. Adjust cable length (B) to obtain recommended lever setting. Be sure shift lever is free to go up into seventh speed position but cannot be moved down into eighth speed slot when

shuttle lever is in reverse position.

Model L355

80. R&R AND OVERHAUL. Shift rails, forks and associated parts are shown in Fig. 109. To remove main shift housing, shift transmission into neutral and unbolt and remove shift cover and housing. Remove shift lever knob and retaining ring (2), then withdraw shift lever (1) from bottom of cover (7). Remove detent springs and balls (15) and drive spring pins out of shift forks (12). Remove shift rails (11) rearward and withdraw forks.

To remove range shift fork (20) or pto shift fork (31), front transmission housing must be separated from rear housing. Rockshaft housing must also be removed from rear transmission housing for access to range shift fork. Loosen set screw (27) and withdraw snap pin (22). Pull shift rail (19) forward and remove range shift fork (20). Remove retainer (25) and drive out spring pin, then remove range shift lever (26) and arm (23). Center case must be removed from front transmission housing to remove pto shift fork (31). Remove retainer (33), then pull rail (32) forward and remove fork. Remove retainer (29) and drive out spring pin, then remove shift lever (28) and arm (18).

Renew all worn or damaged parts. Reassemble by reversing the disassembly procedure.

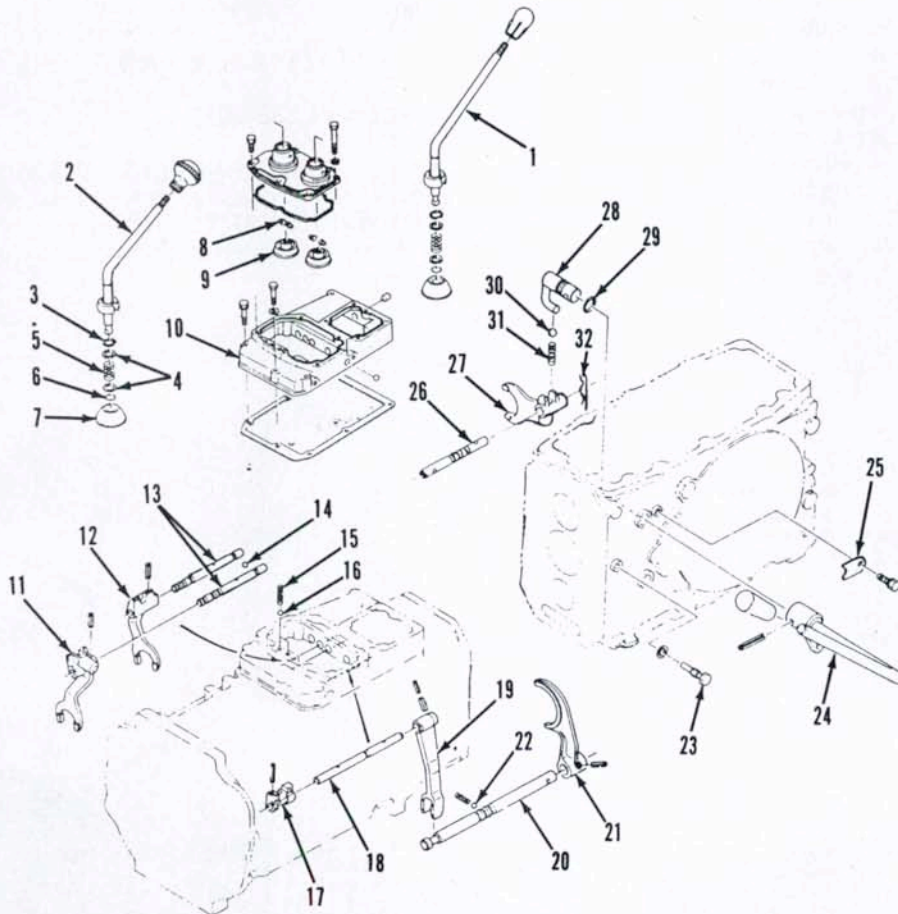

Fig. 107—Exploded view of shifter rails and shafts used on Models L235 and L275.

- | | | |
|------------------------|------------------------|-----------------------|
| 1. Shuttle shift lever | 12. Shift fork | 22. Detent ball |
| 2. Main shift lever | 13. Shift rails | 23. Set screw |
| 3. Retaining ring | 14. Interlock ball | 24. Range shift lever |
| 4. Washer | 15. Spring | 25. Retainer |
| 5. Spring | 16. Detent ball | 26. Shift rail |
| 6. "O" ring | 17. Holder | 27. Range shift fork |
| 7. Shield | 18. Shift rail | 28. Shift arm |
| 8. Pins | 19. Shift arm | 29. "O" ring |
| 9. Shield | 20. Shift rail | 30. Ball |
| 10. Shift housing | 21. Shuttle shift fork | 31. Spring |
| 11. Shift fork | | 32. Retainer pin |

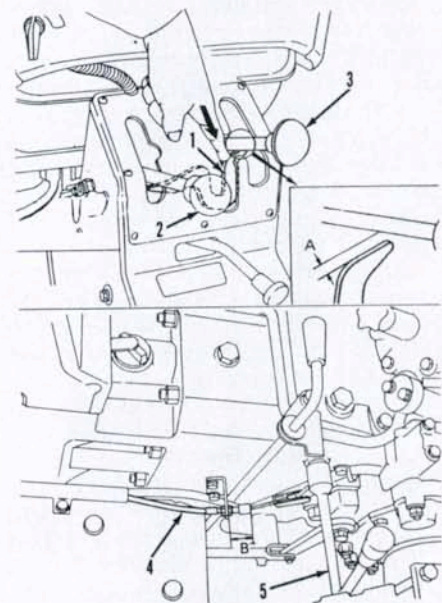

Fig. 108—A shift lockout lever (1) is used on Models L235 and L275 to prevent operating tractor in eighth speed when shuttle is in reverse.

- | | |
|------------------------|----------------------|
| 1. Lockout lever | 4. Lockout cable |
| 2. Shuttle shift lever | 5. Range shift lever |
| 3. Main shift lever | |

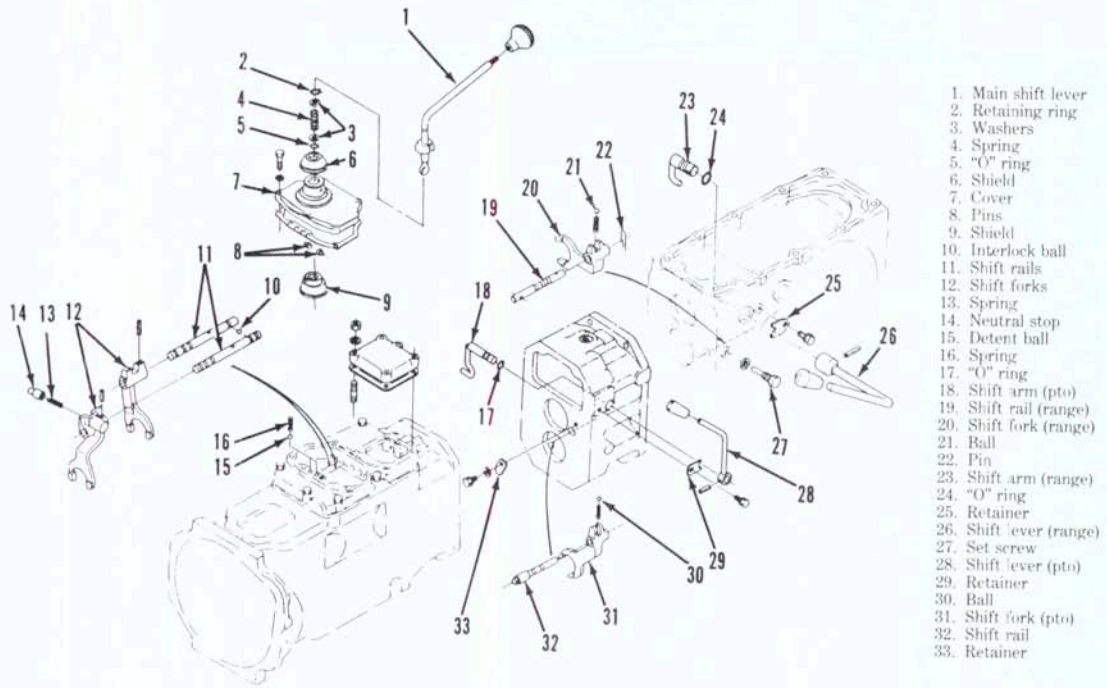

Fig. 109—Exploded view of shift rails, forks and associated parts used on Model L355.

FRONT TRANSMISSION

Models L235-L275

81. REMOVE AND REINSTALL.

To remove front transmission as a unit, first split tractor between engine and clutch housing as outlined in paragraph 64. Remove steering wheel, instrument panel, fuel tank and steering gear assembly. Disconnect shifter lockout cable from range shift lever. Remove both steps, clutch and brake pedals as an assembly and hydraulic suction and pressure pipes. Support rear housing with a suitable stand and front housing with a splitting stand or hoist. Remove housing mounting stud nuts, then separate front housing from rear housing.

When reconnecting transmission housings, tighten stud nuts to a torque of 103-108 N·m (76-86 ft.-lbs.). Tighten engine mounting bolts to a torque of 48-56 N·m (36-41 ft.-lbs.). Adjust shifter lockout cable as outlined in paragraph 79.

82. OVERHAUL. To reassemble main transmission, first shift transmission into neutral and remove shift guide housing. Unbolt and lift off shifter housing with forks. Remove clutch release bearing, hub, fork and shaft from clutch housing. On tractors with single plate engine clutch, remove front cover (1—Fig. 110) from main shaft. On tractors equipped with dual plate engine clutch, remove front cover (1—Fig. 111)

Fig. 110—Exploded view of main transmission gears and shafts used on Models L235 and L275 equipped with single plate engine clutch. Models equipped with a dual plate clutch are similar except for items shown in Fig. 111.

1. Front cover
2. Spacer
3. "O" ring
4. Oil seal
5. Snap ring
6. Washer
7. Bearing
8. Gear (24T)
9. Gear (22T)
10. Mainshaft
11. Spacer
12. Bearing
13. Snap ring
15. Snap ring
16. Washer
17. Bearing
18. Gear (44T)
19. Pto countershaft
20. Retaining clip
21. Splined sleeve
22. Gear (45T)
23. Thrust washer
24. Bearing
25. Washer
26. Spring
27. Pto clutch cams
28. Spacer
29. Bearing
30. Pto drive shaft
31. Snap ring
32. Washer
33. Bearing
34. Thrust washer
35. Retaining ring
36. Gear (31T)
37. Spline boss
38. Retaining clip
39. Gear (38T)
40. Countershaft
41. Gear (44T)
42. Gear (45T)
43. Bearing
44. Coupling
45. Bearing
46. Range shaft
47. Gear (24T)
48. Bearing
49. Thrust washer
50. Thrust washer

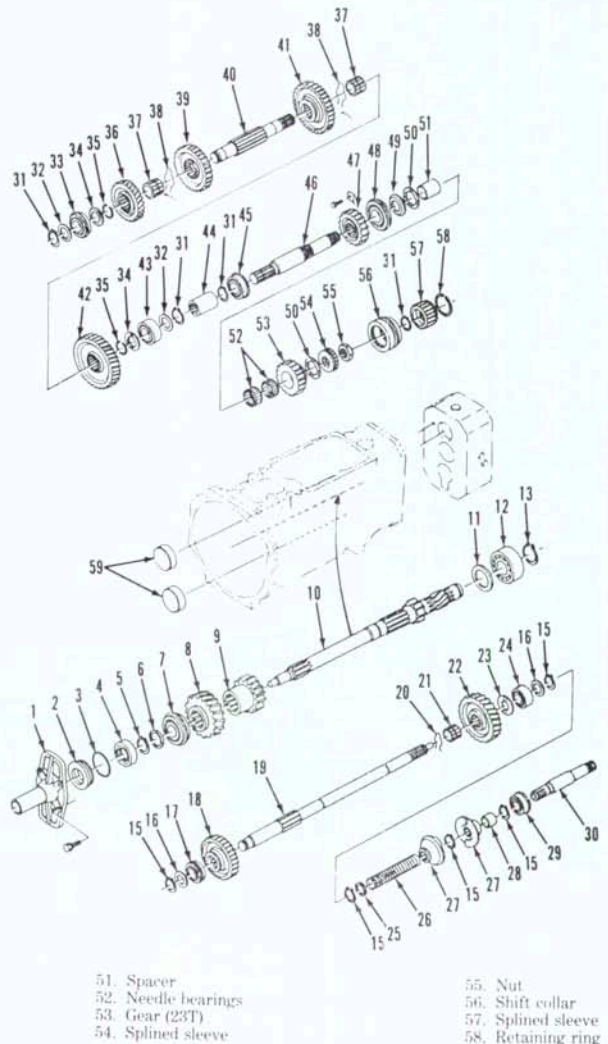

51. Spacer
52. Needle bearings
53. Gear (23T)
54. Splined sleeve
55. Nut
56. Shift collar
57. Splined sleeve
58. Retaining ring

with pto input shaft (4) using two jackscrews to lift cover off housing. Remove retaining ring and pto countershaft gear (16). Remove mounting cap screws from front case (5), then tap pto countershaft rearward and remove case.

Remove retaining clips (38—Fig. 110) from splined bosses (37). Remove retaining ring and slide coupling (44) rearward. Remove bearing (33) from front of countershaft using a suitable puller, then lift countershaft (40) and gears from housing.

On tractors with single plate engine clutch, remove pto clutch cam (27—Fig. 110), spring (26) and spacer (28) from pto countershaft (19). On all models, unbolt and remove center case from rear of transmission housing.

To remove main shaft (10—Fig. 110 or 14—Fig. 111), screw two cap screws into spacer (2 or 8) and pull spacer out of housing. Remove snap ring from front of shaft, then tap shaft assembly rearward out of housing.

Remove pto shift rail and shift fork. On tractors with single plate clutch, remove snap rings from pto countershaft (19—Fig. 110) and tap shaft forward to remove from housing. On tractors with dual plate clutch, tap countershaft (19—Fig. 111) rearward to remove from housing.

To disassemble center housing, proceed as follows: Drive spring pin out of reverse shift fork, then remove shift fork, shift collar and shift rail. Remove nut (55—Fig. 110) and splined sleeve (54), then tap countershaft (46) forward out of case. Remove bearing retainer (8—Fig. 112) from rear of reverse shaft (13) and snap ring from front of shaft. Tap shaft rearward from housing. Remove retainer (7) and tap reverse idler shaft (6) rearward out of case. On tractors equipped with dual plate clutch, separate pto gearcase (18—Fig. 113) from center housing. Remove bearing retainer (2) and snap ring from rear of pto gear shaft (8), then tap shaft forward and withdraw gears (6 and 7). Remove snap ring from front of pto countershaft (22), then tap shaft rearward and withdraw gears (19 and 21).

Inspect all parts for excessive wear or other damage and renew as necessary. To reassemble transmission, reverse the disassembly procedure while observing the following: Be sure oil holes in reverse idler gear (4—Fig. 112) and bushing (3) are aligned and oil groove in spacer (2) is facing gear. When reinstalling countershaft (46—Fig. 110) into center housing, be sure thrust washers (50) fit on inner sleeve (51) and oil groove of thrust collar (49) is towards gear (53). Install a new nut (55) and tighten to a torque of 39-59 N·m (30-43 ft.-lbs.), then stake nut. Tighten front

Fig. 111—Exploded view of mainshaft, pto countershaft and pto input shaft used on Models L235 and L275 equipped with dual plate clutch.

1. Front cover
2. Oil seal
3. Bearing
4. Pto input shaft
5. Front case
6. "O" ring
7. Oil seal
8. Spacer
9. "O" ring
10. Bearing
11. Snap ring
12. Washer
13. Bearing
14. Mainshaft
15. Snap ring
16. Gear
17. Snap ring
18. Bearing
19. Pto countershaft
20. Bearing
21. Spacer
22. Shift collar

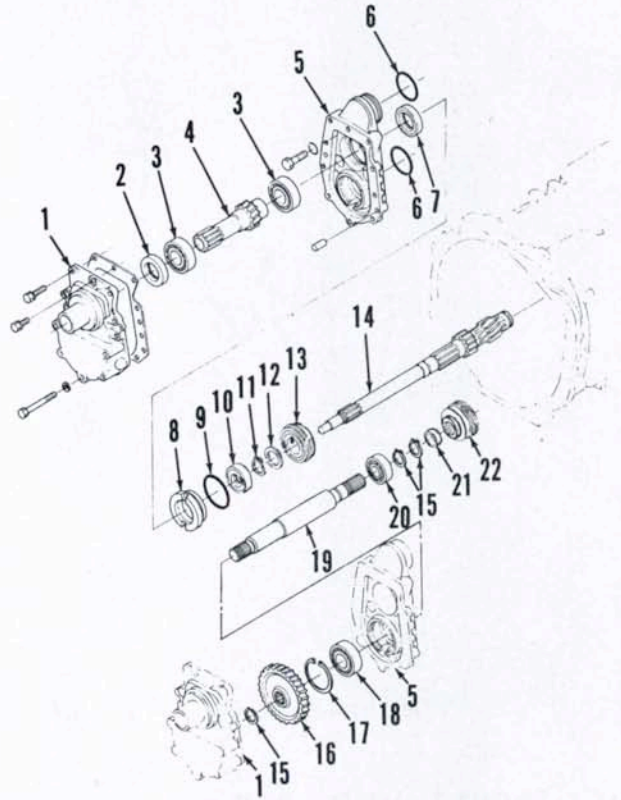

gear housing (dual plate clutch type) mounting cap screws to a torque of 48-56 N· (35-40 ft.-lbs.). Be sure to install seal washer at location "A" (Fig. 114) on shift housing. Tighten seal washer bolt to a torque of 12-20 N·m (10-15 ft.-lbs.) and remainder of mounting bolts to 24-28 N·m (18-20 ft.-lbs.)

Model L355

83. REMOVE AND REINSTALL.
To remove front transmission housing

as a unit, first split tractor between engine and clutch housing as outlined in paragraph 64. Remove steering wheel, instrument panel, fuel tank and steering gear assembly. Remove both steps, clutch and brake pedals as an assembly and hydraulic suction and pressure pipes. Remove hydraulic supply pipe at shuttle valve and disconnect clutch rod at clutch release lever. Unbolt and remove clutch housing with shuttle transmission from main transmission housing. Suitably support front and rear

Fig. 112—Exploded view of reverse shaft and gears located in center housing on Models L235 and L275. Be sure oil holes in bushing (3) and idler gear (4) are aligned when reassembling.

1. Center housing
2. Spacer
3. Bushing
4. Idler gear
5. Thrust washer
6. Idler shaft
7. Retainer
8. Retainer
9. Snap ring
10. Gear (22T)
11. Bearing
12. Gear (19T)
13. Reverse shaft
14. Bearing

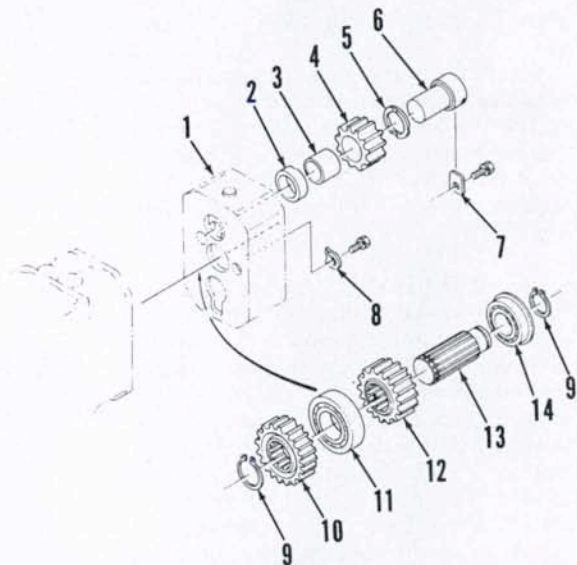

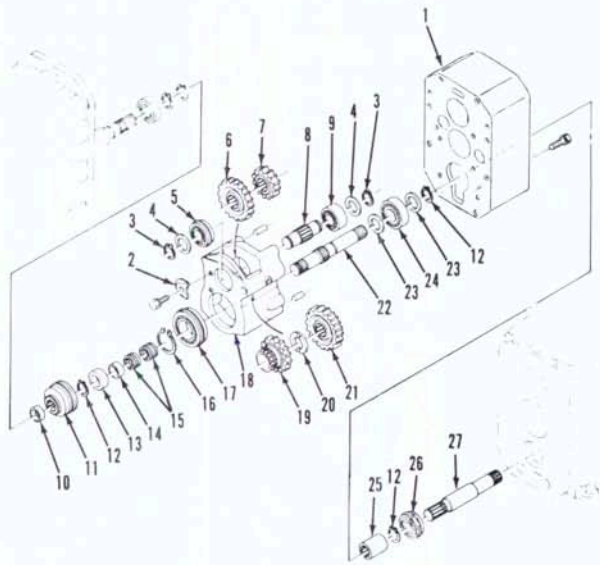

Fig. 113—Exploded view of pto drive gears, shafts and case used on tractors equipped with dual plate clutch.

1. Center housing
2. Bearing retainer
3. Snap ring
4. Washer
5. Bearing
6. Gear (20T)
7. Gear (15T)
8. Pto gear shaft
9. Bearing
10. Spacer
11. Shift collar
12. Snap ring
13. Spacer
14. Spacer
15. Bearings
16. Snap ring
17. Bearing
18. Gearcase
19. Gear (16T)
20. Thrust washer
21. Gear (22T)
22. Countershaft
23. Washers
24. Bearing
25. Coupling
26. Bearing
27. Pto drive shaft

transmission housings, then remove mounting stud nuts and separate housings.

When reconnecting tractor, tighten housing mounting stud nuts to a torque of 103-118 N·m (76-86 ft.-lbs.), clutch housing mounting bolts to 78-90 N·m (57-66 ft.-lbs.) and engine mounting bolts to a torque of 49-56 N·m (36-41 ft.-lbs.) Be sure "O" rings are correctly positioned when reinstalling hydraulic pipes.

84. OVERHAUL. To disassemble main transmission, first shift gears into neutral position and remove shifter housing. Withdraw range countershaft and pto countershaft from rear of transmission housing. Shift sliding gears into two speeds to lock mainshaft, then remove cap screw, washer, gear (27—Fig. 115) and spacer (28) from front of mainshaft (34). Remove front bearing (29) and bearing case (30) using a suitable puller. Remove retainer clips (9), front snap ring, spacer (3), and retaining ring (6) from countershaft (10). Tap countershaft rearward from housing and lift out gears. Tap mainshaft rear-

ward out of housing and withdraw gears (32 and 33).

To disassemble center case, remove snap ring, gear (2—Fig. 116) and spacer

(3) from front of pto gear shaft (5). Remove bearing retainer (9), then tap shaft rearward out of case. Remove bearing retainer, then tap pto countershaft (11) out front of case. Remove pto shift rail and fork.

To reassemble transmission, reverse the disassembly procedure while noting the following: Be sure pto gear (6—Fig. 116) is installed with chamfered side forward. Make certain oil grooves in thrust washers (5—Fig. 115) are toward splined sleeves (8). Tighten mainshaft cap screw to a torque of 50-70 N·m (36-52 ft.-lbs.) Be sure seal washer (2—Fig. 117) is installed on shift housing (1) in proper location. Tighten seal washer cap screw to a torque of 12-20 N·m (9-15 ft.-lbs.) and remainder of mounting cap screws to 24-27 N·m (18-20 ft.-lbs.).

REAR TRANSMISSION HOUSING

Models L235-L275-L355

85. REMOVE AND REINSTALL. To remove rear transmission housing,

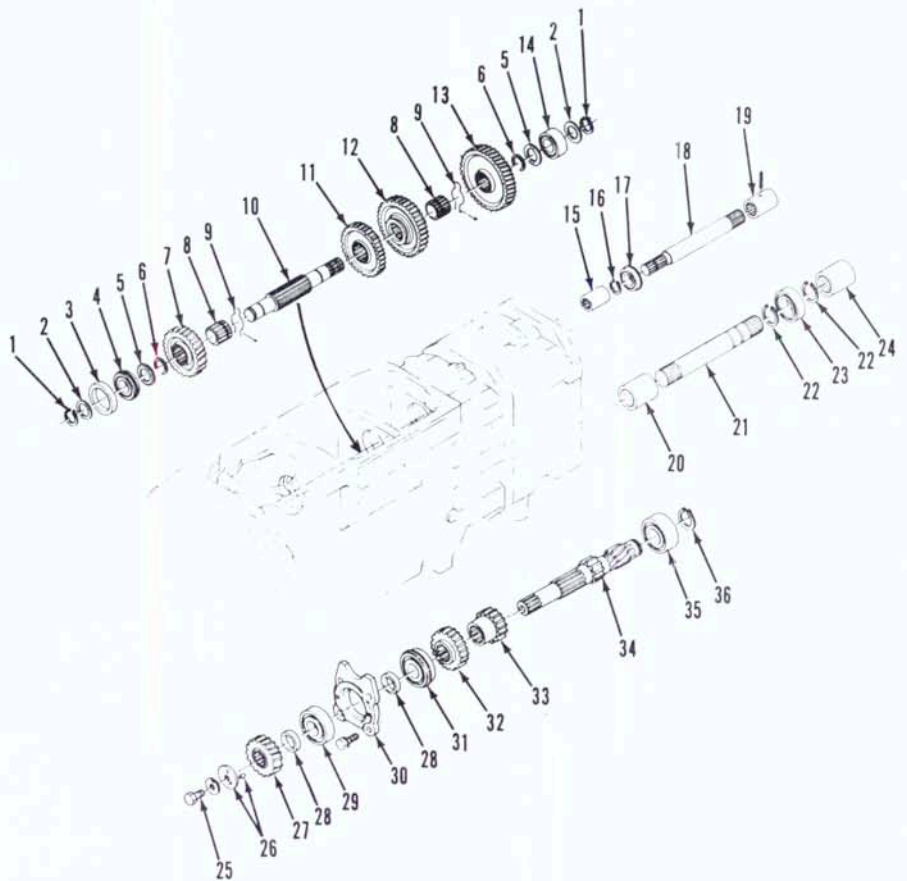

Fig. 115—Exploded view of gears and shafts located in front transmission housing on Model L355.

- | | | | |
|-------------------|--------------------------|------------------------|----------------|
| 1. Snap ring | 10. Countershaft | 19. Coupling | 28. Spacer |
| 2. Washer | 11. Gear (38T) | 20. Coupling | 29. Bearing |
| 3. Spacer | 12. Gear (44T) | 21. Countershaft (pto) | 30. Case |
| 4. Bearing | 13. Gear (45T) | 22. Snap ring | 31. Bearing |
| 5. Thrust washer | 14. Bearing | 23. Bearing | 32. Gear (24T) |
| 6. Retaining ring | 15. Coupling | 24. Coupling | 33. Gear (20T) |
| 7. Gear (31T) | 16. Snap ring | 25. Cap screw | 34. Mainshaft |
| 8. Splined sleeve | 17. Bearing | 26. Washer & pin | 35. Bearing |
| 9. Retainer clip | 18. Countershaft (range) | 27. Gear (18T) | 36. Snap ring |

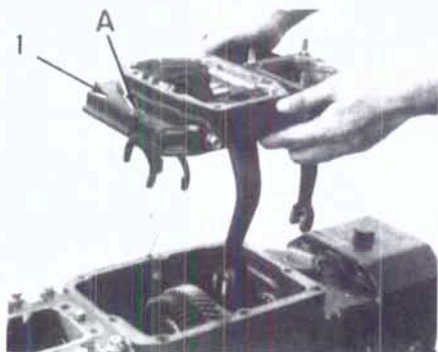

Fig. 114—Install seal washer at location "A" when reinstalling shift housing (1).

first drain oil from transmission housings and rear axle housings. Disconnect brake rods, electrical wiring and hydraulic pipes as necessary. Remove steps and on Models L235 and L275 disconnect shift lockout cable from range shift lever. On models equipped with front wheel drive, disconnect drive shaft. Support front transmission housing with a suitable stand and wedge front axle to prevent tipping. Support rear transmission housing with a suitable splitting stand or hoist, then remove rear axle housings as outlined in paragraph 100. Remove housing mounting stud nuts, then separate rear housing from tractor.

To reinstall transmission housing, reverse the disassembly procedure. Tighten stud nuts to a torque of 103-118 N·m (76-86 ft.-lbs.).

Models L235-L275-L355

86. OVERHAUL. To disassemble rear transmission housing, proceed as follows: Remove differential lock shaft and shift fork. Remove bearing retainer from front of countershaft (2-Fig. 118 or 119) and snap ring (6) from rear of shaft. Tap shaft forward out of housing and lift out gear (3). Wedge a brass rod in ring gear teeth to lock bevel pinion shaft (18), then remove nut (8) from front of shaft. Remove differential bearing cases and lift differential assembly from rear housing. Be sure to retain shims with each bearing case for use in reassembly. Loosen shift rail set screw

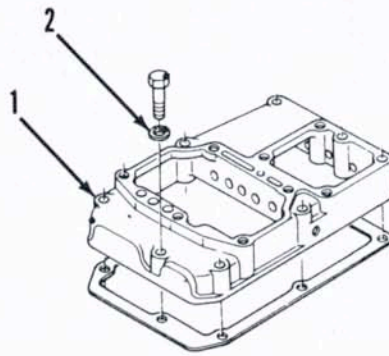

Fig. 117—A seal washer is used on shifter housing front mounting cap screw.

- 1. Shifter housing
- 2. Seal washer

and remove retainer pin, then pull shift rail forward and withdraw shift fork. Disengage snap ring (15) from its groove, then tap pinion shaft (18) rear-

ward and remove gears. Unbolt and remove front bearing (10) and bearing case (11). Retain shims (12) for use in reassembly. On Models L235 and L275, remove cap screws securing pto shaft bearing case (35-Fig. 118), then pull pto output shaft (33) and bearing case rearward as a unit from housing. Remove snap ring from rear of pto drive shaft (21) and bearing retainer (13) from front of shaft, then tap shaft forward out of housing. On Model L355, remove snap ring from front of pto output shaft (33-Fig. 119) and remove front bearing (21) with a suitable puller. Remove retainer (22), thrust washers (23 and 24), bearings (25) and gear (26). Remove bearing case mounting screws, then pull shaft and bearing case (35) rearward from housing. On all models, remove nut (28-Fig. 118 or 119) and snap ring (29), then press bearing case and bearing off shaft. Drive oil seal (32) out of case.

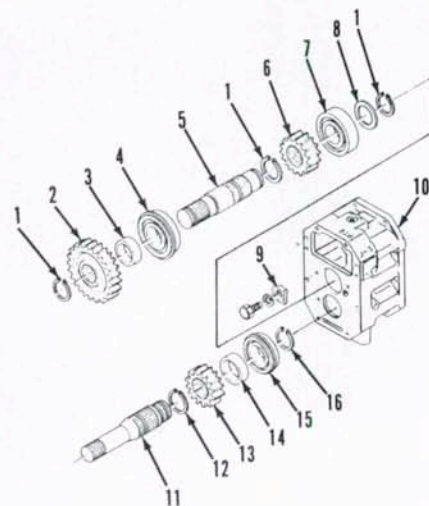

Fig. 116—Exploded view of gears and shafts located in center case on Model L355.

- 1. Snap ring
- 2. Gear (23T)
- 3. Spacer
- 4. Bearing
- 5. Pto gear shaft
- 6. Gear (14T)
- 7. Bearing
- 8. Thrust washer
- 9. Bearing retainer
- 10. Center case
- 11. Pto countershaft
- 12. Snap ring
- 13. Gear (14T)
- 14. Spacer
- 15. Bearing
- 16. Snap ring

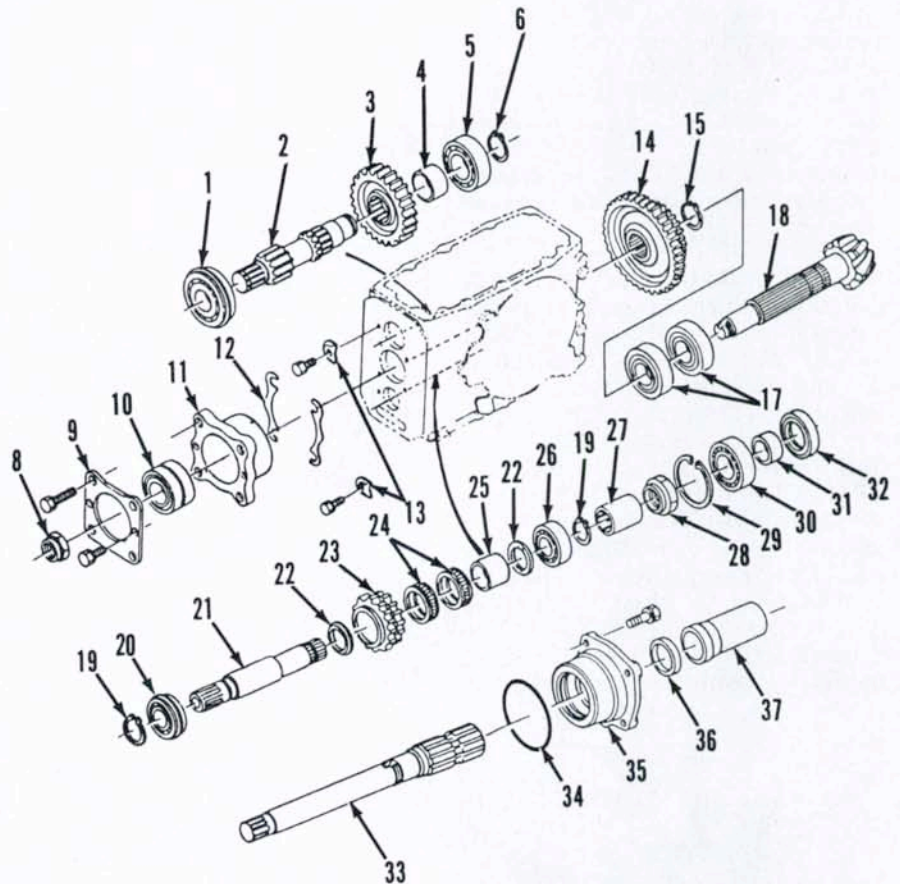

Fig. 118—Exploded view of gears and shafts located in rear transmission housing on Models L235 and L275.

- 1. Bearing
- 2. Range countershaft
- 3. Gear (27T)
- 4. Spacer
- 5. Bearing
- 6. Snap ring
- 8. Nut
- 9. Cover
- 10. Bearing
- 11. Bearing case
- 12. Shim
- 13. Bearing retainers
- 14. Gear (23-46T)
- 15. Snap ring
- 17. Bearings
- 18. Bevel pinion shaft
- 19. Snap ring
- 20. Bearing
- 21. Pto drive shaft
- 22. Thrust washer
- 23. Gear
- 24. Shim
- 25. Spacer
- 26. Bearing
- 27. Coupling
- 28. Nut
- 29. Snap ring
- 31. Bearing
- 32. Oil seal
- 33. Pto output shaft
- 34. "O" ring
- 35. Bearing case
- 36. Slinger
- 37. Cap

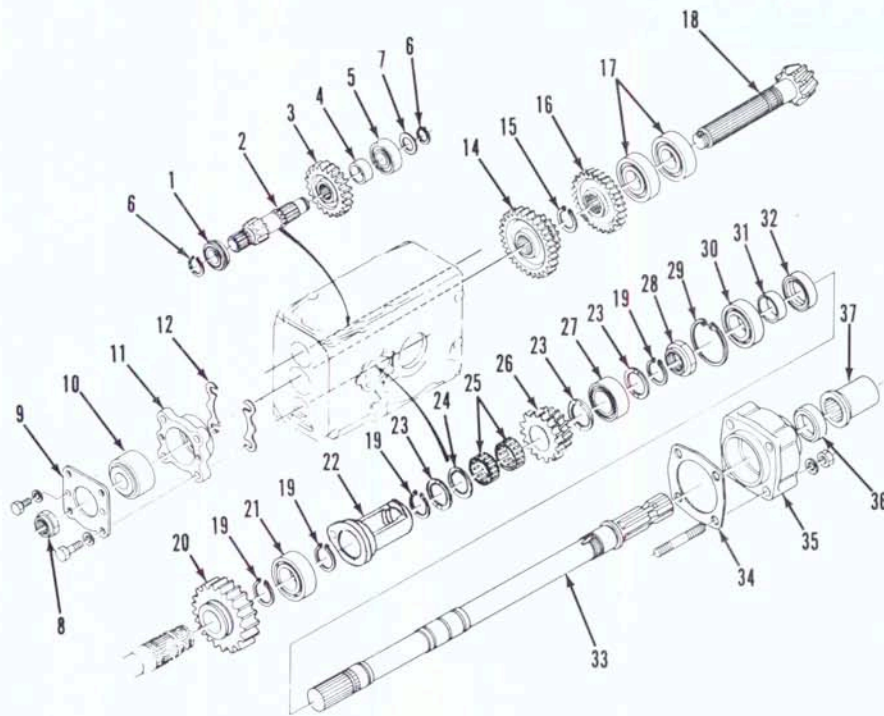

Fig. 119—Exploded view of gears and shafts located in rear transmission housing on Model L355.

- | | | |
|-----------------------|------------------------|----------------------|
| 1. Bearing | 14. Gear (14-37T) | 26. Gear (15-21T) |
| 2. Range countershaft | 15. Snap ring | 27. Bearing |
| 3. Gear | 16. Gear (27T) | 28. Nut |
| 4. Spacer | 17. Bearings | 29. Snap ring |
| 5. Bearing | 18. Bevel pinion shaft | 30. Bearing |
| 6. Snap ring | 19. Snap ring | 31. Sleeve |
| 7. Washer | 20. Gear (23T) | 32. Oil seal |
| 8. Nut | 21. Bearing | 33. Pto output shaft |
| 9. Cover | 22. Retainer | 34. Gasket |
| 10. Bearing | 23. Thrust washer | 35. Bearing case |
| 11. Bearing case | 24. Washer | 36. Slinger |
| 12. Shim | 25. Needle bearings | 37. Cap |

To reassemble rear transmission housing, reverse the disassembly procedure while noting the following: Use a new nut (28) on pto output shaft and tighten to a torque of 150-195 N·m (110-145 ft.-lbs.). Stake nut after tightening. Be sure oil groove of thrust washers faces gear (23—Fig. 118 or 26—Fig. 119). Bevel pinion shaft (18—Fig. 118 or 119)

is available only as a matched set with bevel ring gear. If renewing shaft or bearings, backlash and gear mesh must be checked and adjusted when reassembling as outlined in paragraphs 95 and 96. Reinstall bevel pinion shaft assembly using original shims. Install a new nut (8) and tighten to a torque of 147-196 N·m (109-145 ft.-lbs.). Stake

nut after tightening. Be sure countershaft gear (3) is installed with chamfer facing forward.

SHUTTLE TRANSMISSION (Model L355)

87. A hydraulically controlled shuttle transmission (forward-reverse) is used on all L355 tractors. Hydraulic pressure supply from main hydraulic pump passes through a flow priority valve which directs a constant flow of oil to shuttle control valve regardless of engine speed. Clutch pressure and lubricating oil pressure are regulated by relief valves located in shuttle control valve assembly. Hydraulic shuttle clutch packs are located in clutch housing.

SHUTTLE CONTROL VALVE

Model L355

88. **TEST AND ADJUST.** To check clutch relief pressure and lubricating oil pressure, proceed as follows: Remove hood and install a pressure gage at plug location "L" (Fig. 120) to check lubricating oil pressure. Forward clutch pressure is checked at port "F" and reverse clutch pressure is checked at port "R". Be sure hydraulic oil is at normal operating temperature when checking pressure. Operate engine at 2600 rpm and observe lubricating pressure which should be 100-195 kPa (14-28 psi). Position shuttle control lever at "Forward" or "Reverse" and check clutch pressure reading. Clutch pressure relief setting should be 1590-1740 kPa (230-250 psi) in either direction.

If pressure readings are not within specifications, change thickness of shims (12 or 30—Fig. 121) to obtain recommended relief pressure. Changing shim (30) thickness 1.0 mm (0.04 inch) will change lubricating oil pressure approximately 11 kPa (1.5 psi). Changing thickness of shim (12) 1.0 mm (0.04 inch) will change clutch relief pressure approximately 182 kPa (26.5 psi).

89. **R&R AND OVERHAUL.** To remove shuttle control valve, first remove steering wheel, instrument panel and fuel tank assembly. Disconnect control cable and hydraulic supply pipe from valve. Remove mounting cap screws and withdraw valve from clutch housing.

To disassemble shuttle valve, remove selector cover (24—Fig. 121) and selector valve (20) as a unit. Remove retaining nut and separate selector lever (27),

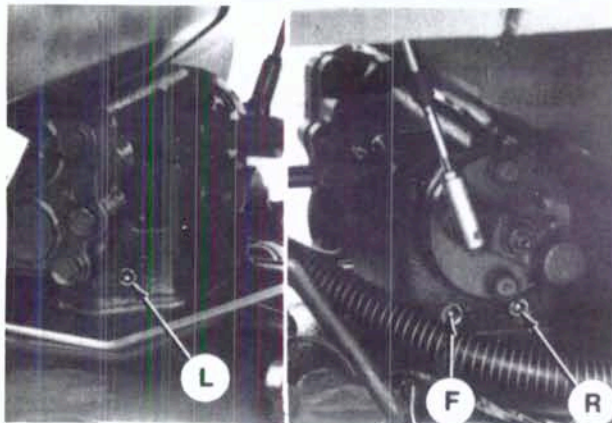

Fig. 120—Location of hydraulic pressure test ports on shuttle valve used on Model L355.

- L. Lubricating oil pressure
- F. Forward clutch pressure
- R. Reverse clutch pressure

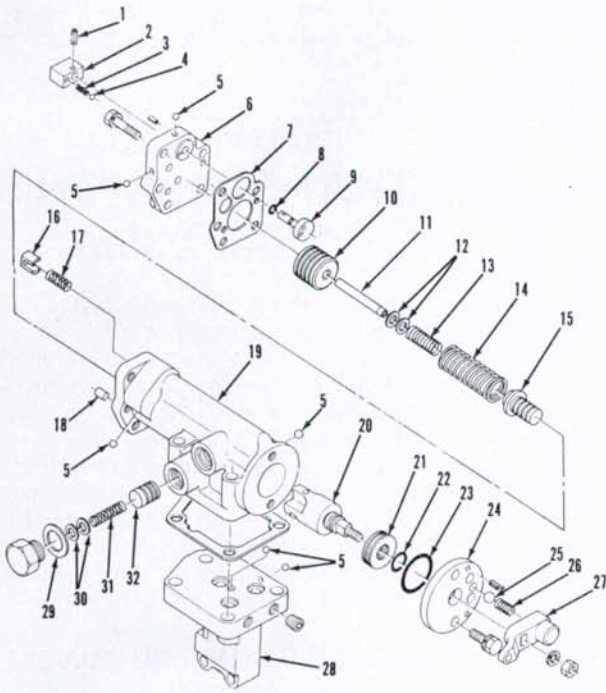

Fig. 121—Exploded view of shuttle control valve used on Model L355.

- | | | |
|-------------------|---------------------------|-----------------------------|
| 1. Spring pin | 12. Shims | 22. "O" ring |
| 2. Orifice lever | 13. Spring | 23. "O" ring |
| 3. Spring | 14. Spring | 24. Selector cover |
| 4. Detent ball | 15. Relief valve (clutch) | 25. Detent ball |
| 5. Balls | 16. Check valve | 26. Spring |
| 6. Valve cover | 17. Spring | 27. Valve lever |
| 7. Gasket | 18. Dowel | 28. Mounting spacer |
| 8. "O" ring | 19. Valve body | 29. Washer |
| 9. Rotary orifice | 20. Selector valve | 30. Shims |
| 10. Piston | 21. Thrust bearing | 31. Spring |
| 11. Pin | | 32. Relief valve (lube oil) |

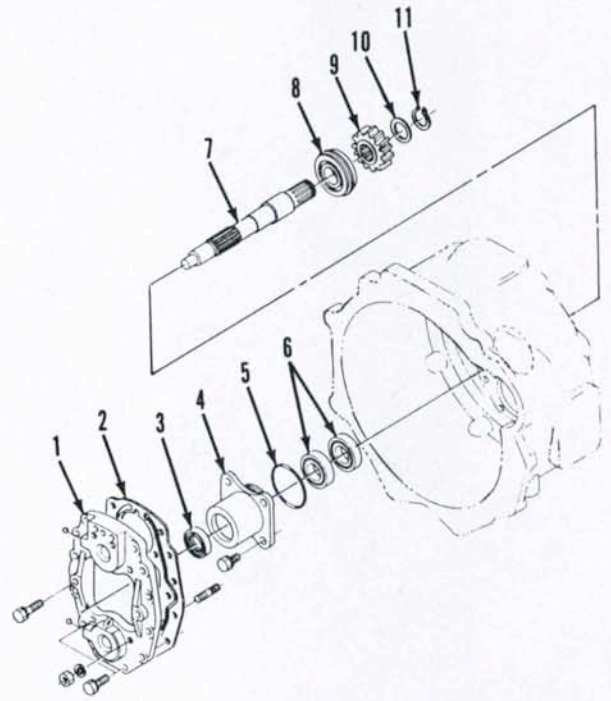

Fig. 123—Exploded view of hydraulic shuttle mainshaft assembly.

- | | |
|-----------------------|---------------|
| 1. Hydraulic manifold | 7. Mainshaft |
| 2. Gasket | 8. Bearing |
| 3. Oil seal | 9. Gear |
| 4. Bearing case | 10. Washer |
| 5. "O" ring | 11. Snap ring |
| 6. Bearings | |

cover, thrust bearing (21) and valve. Remove valve cover (6) and withdraw check valve (16), piston (10), springs, shims (12) and poppet (15). Remove plug and withdraw lubricating oil relief piston (32). Drive out spring pin (1) and remove orifice lever (2) and rotary valve (9) from cover.

Fig. 124—Exploded view of forward (bottom clutch pack) and reverse (top clutch pack) shuttle clutch assembly used on Model L355.

- | | |
|---------------------|---------------------|
| 1. "O" ring | 19. Retaining ring |
| 2. Seal retainers | 20. Gear |
| 3. "O" ring | 21. Inner race |
| 4. Seal rings | 22. Clutch case |
| 5. Snap ring | 23. "O" ring |
| 6. Washer | 24. Piston |
| 7. Bearing | 25. Spring |
| 8. Thrust washer | 26. Spring seat |
| 9. Retaining ring | 27. Snap ring |
| 10. Gear | 28. Steel plate (4) |
| 11. Inner race | 29. Clutch disc (4) |
| 12. Clutch case | 30. Back-up plate |
| 13. "O" ring | 31. Snap ring |
| 14. Piston | 32. Set screw |
| 15. Spring | |
| 16. Spring seat | |
| 17. Snap ring | |
| 18. Steel plate (4) | |
| 19. Clutch disc (4) | |
| 20. Back-up plate | |
| 21. Snap ring | |
| 22. Set screw | |
| 23. Clutch shaft | |
| 24. Clutch shaft | |
| 25. Thrust washer | |
| 26. Needle bearing | |
| 27. Gear | |
| 28. Gear | |
| 29. Bearing | |
| 30. Washer | |
| 31. Snap ring | |
| 32. Housing | |

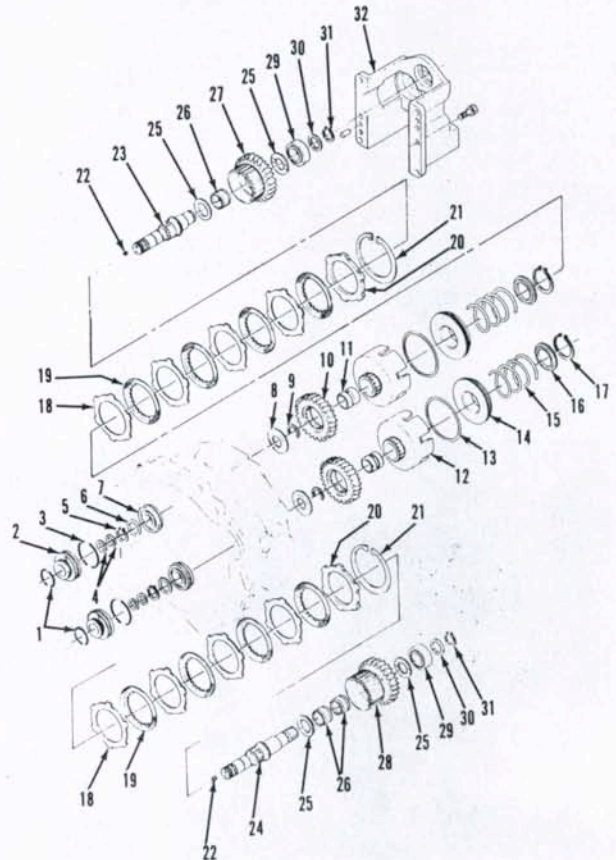

Fig. 122—Exploded view of shuttle gearcase and reverse idler gear used on Model L355.

- | | |
|-----------------------|----------------|
| 1. Inner race | 5. Idler shaft |
| 2. Thrust washers | 6. Gearcase |
| 3. Needle bearings | 7. Set screw |
| 4. Reverse idler gear | |

Inspect all parts for wear, scoring or other damage and renew as necessary. Be sure to renew all "O" rings.

Reassemble valve by reversing disassembly procedure. Reinstall valve assembly using new "O" rings and tighten mounting bolts to a torque of 24-27 N·m (18-20 ft.-lbs.). Check and adjust relief valve pressure as outlined in paragraph 88.

SHUTTLE CLUTCHES

Model L355

90. R&R OVERHAUL. To remove shuttle transmission, tractor must first be split between engine and clutch housing as outlined in paragraph 64. Remove steering wheel, instrument panel, fuel tank and support assembly and steering gear assembly. Remove hydraulic pipe from shuttle valve and disconnect clutch rod from clutch release lever. Support transmission housing and clutch housing separately, then remove clutch housing mounting bolts. Separate clutch housing from transmission housing.

To disassemble shuttle transmission, remove set screw (7-Fig. 122) and mounting cap screws from gearcase (6). Use two jackscrews to lift gearcase from clutch housing. Remove reverse idler shaft (5), gear (4) and bearings from gearcase. Remove shuttle control valve and valve spacer block. Remove mounting cap screws from hydraulic manifold (1-Fig. 123), then use two jackscrews to lift manifold off clutch housing. Screw two cap screws into upper and lower shaft seal retainers (2-Fig. 124), then pull retainers out of housing. Remove seal rings (4) and snap ring (5), then tap shafts rearward to remove clutch assemblies. Remove cap screws from mainshaft bearing case (4-Fig. 123), then withdraw mainshaft assembly from

clutch housing. Remove snap ring (11) and gear (9), then tap mainshaft out of bearing case.

Disassembly procedure is the same for either clutch pack. Remove retaining ring (9-Fig. 124), gear (10) and inner race (11), then separate clutch shaft assembly from clutch pack. Remove snap ring (31), then tap clutch shaft (23 or 24) out of bearings and gear (27 or 28). Remove snap ring (21) and remove back-up plate (20), clutch discs (19) and steel plates (18) from clutch case (12). Use special clutch tool (1-Fig. 125), Code No. 07916-52071, or a similar horseshoe shaped tool and a press to compress piston return spring (15-Fig. 124). Remove snap ring (17), then slowly release spring tension and remove spring seat (16), spring (15) and piston (14) from clutch case.

Inspect all parts for excessive wear or other damage. Renew clutch discs and plates if worn, burned or warped. Renew all "O" rings, seal rings and oil seals.

To reassemble clutch pack, reverse the disassembly procedure. Be sure thrust washers are installed with their oil groove toward gears. Lubricate seals and "O" rings with clean oil prior to reassembly. Tighten hydraulic manifold mounting cap screws to a torque of 24-27 N·m (18-20 ft.-lbs.). Be sure "O" rings are in place when reinstalling shuttle valve and valve mounting spacer. Tighten spacer and valve mounting cap screws to a torque of 24-27 N·m (18-20 ft.-lbs.).

DIFFERENTIAL AND BEVEL GEARS

All Models

91. REMOVE AND REINSTALL.

To remove differential and main drive bevel ring gear, first drain oil from transmission and final drive housings. Wedge front axle to prevent tractor from tipping, securely block front and rear transmission housing and remove rear wheels, fenders and seat. Remove differential lock pedal. Support final drive housing with a suitable hoist, remove mounting cap screws and detach both final drives from transmission housing. Disconnect brake linkage from brake cam lever. Remove brake assemblies and differential gear shafts from transmission housing. Disconnect hydraulic pipes from rockshaft housing, remove mounting cap screws and lift housing off transmission housing. Remove differential lock cam lever and shift fork. Support differential assembly, then use two jackscrews to lift bearing cases off housing. Lift differential assembly out of rear housing. Be sure to identify shims and bearing cases so they can be reinstalled in their original positions. Bearing cases are not interchangeable.

If main drive bevel pinion shaft requires renewal, rear transmission housing must be separated from front housing. Remove bevel pinion shaft as outlined in TRANSMISSION section.

Fig. 126—Exploded view of differential assembly and related components used on Models L185, L235, L245 and L275. Pinion gear bushings (7) are not used on Model L275.

1. Differential lock shifter
2. Bevel ring gear
3. Differential case
4. Pinion shaft
5. Key
6. Thrust washer
7. Bushing
8. Pinion gear
9. Thrust washer
10. Side gear
11. Bearing
12. Shim
13. Bearing case
14. Oil seal
15. Bearings
16. Differential gear shaft
17. Differential lock pedal
18. Spring
19. Pedal bracket
20. Shift fork
21. Cam

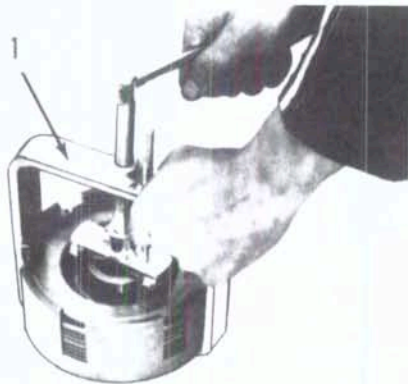
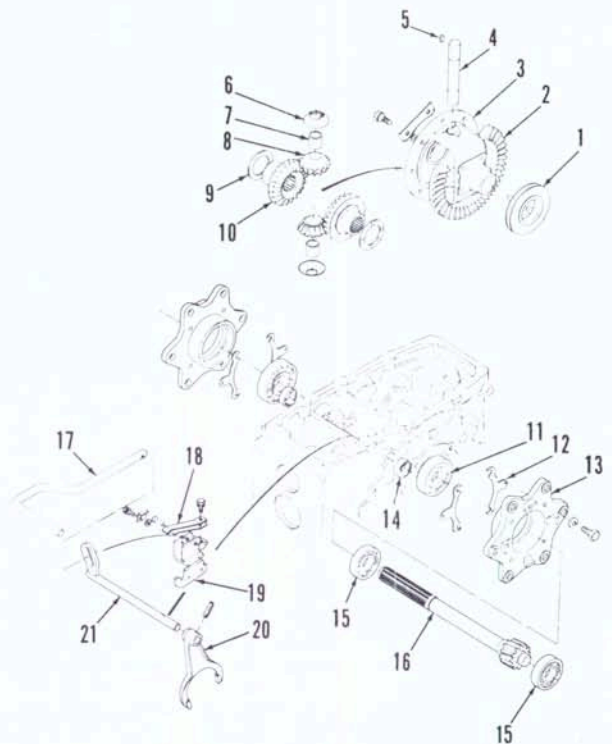

Fig. 125—Use special tool (1) or similar horseshoe shape tool and a press to compress piston return spring during disassembly and reassembly.

When reinstalling differential unit, make certain bearing cases and shim packs are reinstalled in their original positions. Check and adjust bearing preload, backlash and tooth contact as outlined in paragraphs 94, 95 and 96.

Models L185-L235-L245-L275-L285

92. OVERHAUL. An exploded view of differential assembly is shown in Fig. 126 or 127. To disassemble, unbolt and lift off main drive bevel ring gear (2). Remove bearings (11) and differential lock shifter (1) from differential case (3). Push differential pinion shaft (4) out key (5) end of housing and remove pinion gears (8) and side gears (10).

Maximum allowable clearance of side gears (10) in differential case is 0.4 mm (0.016 inch). Maximum allowable clearance of pinion gear bushing (7) on shaft (4) is 0.3 mm (0.012 inch). Backlash between side gears and pinion gears should not exceed 0.4 mm (0.016 inch). If backlash is excessive, adjust by renewing thrust washers (6 and 9).

When reassembling differential, lubricate side gears, pinion shaft, pinion gear and bushing with molybdenum disulfide. Tighten bevel ring gear mounting bolts to a torque of 69-81 N·m (50-60 ft.-lbs.).

Models L295-L305-L345-L355

93. OVERHAUL. An exploded view of differential assembly is shown in Fig. 128. To disassemble, unbolt and remove main drive bevel ring gear (15). Remove case cover (3) and side gear (5). Use a punch through dowel pin holes in case cover to tap off carrier bearing (27). Pull carrier bearing off differential case (14) and remove differential lock shifter (16). Remove snap rings (9) and set collars (10), then screw two cap screws into bushings (13) and pull bushings out of case. Scribe match marks on side gears and pinion gears. Remove keys (12) and pull pinion shafts (11) out of case. Remove pinion gears (6), side gear and washers.

Maximum allowable clearance between side gear boss and bore of differential case or case cover is 0.4 mm (0.016 inch). Clearance between pinion shaft and pinion gear bushings should not exceed 0.3 mm (0.012 inch). Maximum allowable backlash between side gears and pinion gears is 0.4 mm (0.016 inch). If backlash is excessive, adjust by changing thickness of thrust washers (4) and (8). Be sure thrust washers are same thickness on both side gears.

When reassembling differential, apply molybdenum disulfide to side gear bosses and bores of differential case and

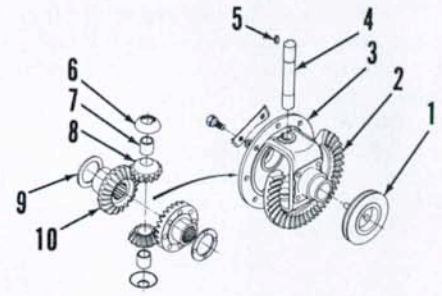

Fig. 127—Exploded view of differential assembly and related components used on Model L285. Refer to Fig. 126 legend except for shaft oil seal (22).

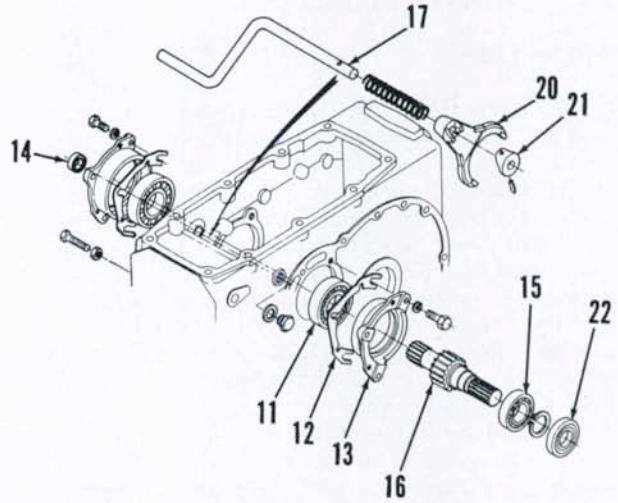
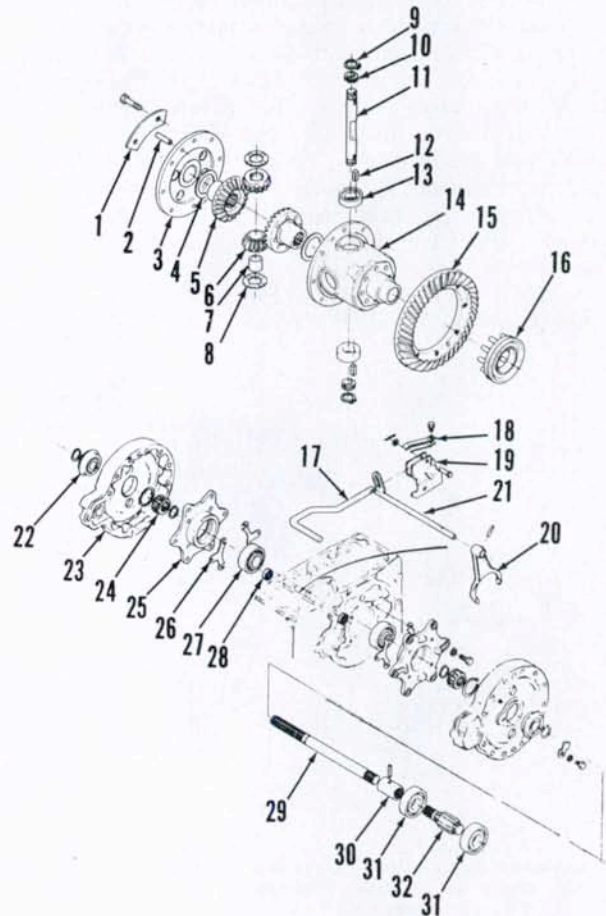

Fig. 128—Exploded view of differential assembly and related components used on Models L295, L305, L345 and L355.

1. Lock plate
2. Dowel pin (2)
3. Cover
4. Thrust washer
5. Side gear (2)
6. Pinion gear (4)
7. Bushing
8. Thrust washer
9. Snap ring
10. Set collar
11. Pinion shaft (2)
12. Key
13. Bushing
14. Differential case
15. Bevel ring gear
16. Differential lock shifter
17. Differential lock pedal
18. Spring
19. Pedal bracket
20. Shift fork
21. Cam
22. Bearing
23. Brake housing
24. Splined sleeve
25. Bearing case
26. Shims
27. Bearing
28. Oil seal
29. Differential gear shaft
30. Coupling
31. Bearing
32. Shaft



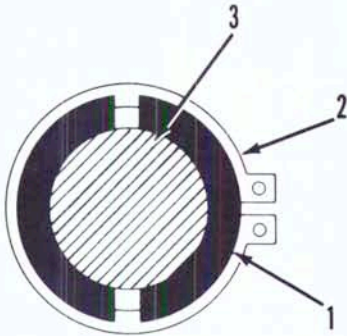

Fig. 129—Position set collars (1) and snap rings (2) as shown when reinstalling differential pinion shafts (3) on Models L295, L305, L345 and L355.

cover. Align match marks on side and pinion gears made prior to disassembly. Position set collars (1—Fig. 129) and snap rings (2) as shown. Tighten bevel ring gear mounting bolts to a torque of 61-70 N·m (45-50 ft. -lbs.) Be sure lockplates (1—Fig. 128) cover dowel pins (2).

All Models

94. BEARING PRELOAD. To check differential bearing preload, measure torque required to rotate bevel pinion shaft and differential assembly using a torque wrench as shown in Fig. 130. Rotating torque should be 0.4-0.9 N·m (4-8 in.-lbs.) on Models L185, L245 and L285; 1.4-4.1 N·m (13-36 in.-lbs.) on Model L235; 3.9-6.4 N·m (35-66 in.-lbs.) on Model L275; 0.9-1.1 N·m (8-10 in.-lbs.) on Models L295, L305, L345 and L355. Adjust preload by changing thickness of differential carrier bearing shims until desired rotating torque is obtained.

95. BACKLASH ADJUSTMENT. Backlash between bevel pinion gear and bevel ring gear should be 0.20-0.25 mm (0.008-0.010 inch). To check backlash, position a dial indicator against tip of one ring gear tooth (Fig. 131). Secure pinion shaft, move ring gear by hand and

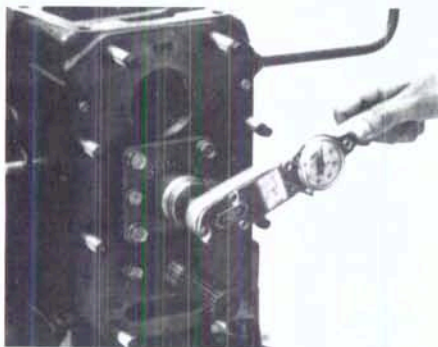

Fig. 130—Use a torque wrench as shown to check torque required to rotate differential assembly. Refer to text.

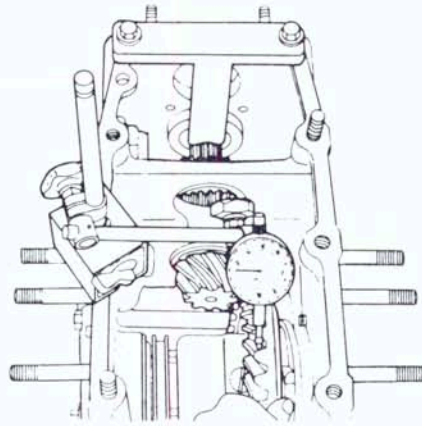

Fig. 131—Use dial indicator to check backlash between bevel ring gear and pinion gear.

note dial indicator reading.

If backlash is too large, remove bearing case shims from ring gear side and install removed shims on opposite side. If backlash is too small, remove shims from differential case side and install removed shims on opposite side.

NOTE: Do not change total shim pack thickness as bearing preload adjustment would be affected.

96. MESH POSITION. To check tooth contact between bevel pinion and ring gear teeth (mesh position), apply a light coat of red lead over several ring gear teeth at three different positions around ring gear. Turn pinion shaft (Fig. 132) while applying resistance to ring gear rotation by pressing a block of wood against ring gear. Check gear tooth contact area (red lead will be wiped off) and compare with patterns shown in Fig. 133.

Desired tooth engagement is shown at "A". Contact at top of teeth "B" indicates shallow meshing. Remove bearing case shim from ring gear side and install on opposite side. Meshing too deep as shown in "C" is corrected by removing shim from differential case side and installing same shim on ring gear side. Tooth contact at toe of ring gear "D" in-

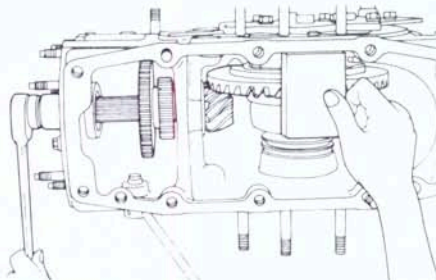

Fig. 132—To check mesh position of ring gear and pinion teeth, turn pinion shaft while applying light resistance to ring gear.

icates pinion shaft needs to be moved toward ring gear. Remove pinion shaft shim to move pinion gear closer to ring gear. To maintain correct backlash, bevel ring gear must be moved to the right (away from bevel pinion gear). Mesh pattern "E" indicates tooth contact is too deep and pinion gear should be moved away from ring gear. Add shims to pinion shaft bearing case as necessary. Move ring gear toward pinion gear (remove shim from ring gear side and install same shim on differential case side) to maintain correct backlash setting.

DIFFERENTIAL LOCK

97. On all models, differential lock coupler mounts on differential case. When pedal is actuated, differential side gear is locked to differential case by pins machined on differential lock coupler. With one side gear locked, differential must turn as a unit and rear wheels turn together regardless of traction.

98. REMOVE AND REINSTALL. To remove differential lock actuating mechanism, first remove seat and rockshaft housing. Remove pin securing foot pedal to mounting bracket (19—Fig. 126 or 128), then remove pedal and bracket. Drive spring pin from shift fork (20), then withdraw actuating cam (21) and fork. Drive out seals (14—Fig. 126 or 28—Fig. 128). Differential lock shifter (1 or 16) can be removed after differential unit is removed.

To reinstall differential lock actuating mechanism, reverse the removal procedure.

Model L285

99. REMOVE AND REINSTALL. To remove differential lock actuating mechanism, first remove seat and rockshaft housing. Drive spring pin out

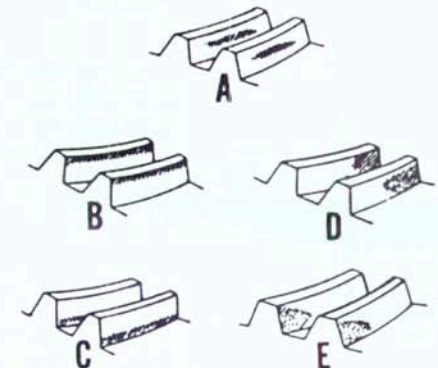

Fig. 133—Typical gear tooth mesh patterns on ring gear. Desired tooth contact is indicated in pattern "A". Refer to text for adjustment procedure.

of cam (21 - Fig. 127), then withdraw actuator pedal (17) and lift out cam, shift fork and spring. Drive oil seal (14) out right side of housing. Differential unit must be removed to remove differential lock shifter (1).

To reinstall differential lock actuating mechanism, reverse the removal procedure.

FINAL DRIVE

All Models

100. REMOVE AND REINSTALL.

To remove final drive assemblies, first drain oil from transmission housing and final drive housings. Support rear of tractor with a suitable stand and wedge front axle to prevent tipping. Remove rear wheel and fenders. On all tractors except Model L185, remove differential lock pedal and mounting bracket. On Model L185, remove brake assemblies as outlined in paragraph 107. On all models, support axle housing with a suitable hoist. Remove axle housing mounting cap screws and stud nuts, then separate final drive from transmission housing.

To reinstall final drive assembly, reverse the removal procedure. Be sure to tighten cap screws or stud nuts (1 and 2 - Fig. 134) first, then tighten remaining cap screws and nuts in diagonal order to a torque of 75-90 N·m (55-65 ft.-lbs.) on all tractors except Model L355 which should be 105-115 N·m (75-85 ft.-lbs.).

Models L185-L245

101. OVERHAUL. To disassemble final drive, first remove axle case mounting bolts and separate axle case (3 - Fig. 135) from cover (11). Secure axle (15) in a vise, then remove nut (4) and bearing (5). Remove bull gear (8) and differential gear shaft (2) as an assembly from cover. Tap axle shaft out of cover

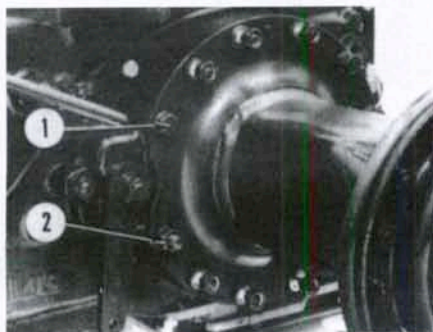
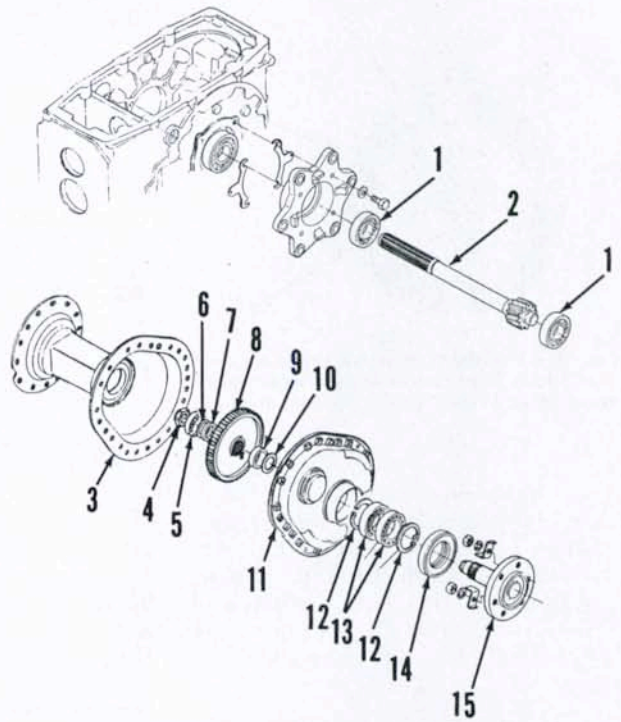

Fig. 134—When reinstalling final drive, tighten cap screws or stud nuts (1 and 2) first.

Fig. 135—Exploded view of final drive assembly used on Model L245. Final drive used on Model L185 is similar except a single axle outer bearing (13) is used.

1. Bearings
2. Differential gear shaft
3. Axle case
4. Nut
5. Bearing
6. Shim
7. Spacer
8. Bull gear
9. Spacer
10. Shim
11. Cover
12. Snap ring
13. Bearings
14. Oil seal
15. Axle shaft



and remove bearings (13) and oil seal (14).

Inspect all parts for excessive wear or other damage. Backlash between differential gear shaft (2) and bull gear (8) should not exceed 0.5 mm (0.020 inch).

When reassembling final drive, install oil seal (14) with lip facing inward. Be sure to reinstall gear shaft (2) and bull gear (8) together. Make certain spacers (7 and 9) are against bull gear and shims (6 and 10) are against bearings. Tighten axle nut (4) to a torque of 150-195 N·m (110-145 ft.-lbs.). Tighten axle cover alignment bolts (A - Fig. 136) first, then tighten cover mounting cap screws evenly to a torque of 48-56 N·m (36-41 ft.-lbs.).

Model L285

102. OVERHAUL. To disassemble final drive assembly, secure axle shaft (10 - Fig. 137) and remove nut (1). Remove bearing (2) and bull gear (3). Remove cap screws securing seal retainer (9), then tap axle shaft out of axle housing.

Inspect all parts for wear or other damage and renew as necessary.

To reassemble final drive, reverse the disassembly procedure. Be sure to lubricate lip of oil seal (7) before reinstalling axle shaft. Tighten nut (1) to a torque of 195-245 N·m (145-180 ft.-lbs.).

Models L235-L275

103. OVERHAUL. To disassemble final drive, first separate axle case

(1 - Fig. 138) from cover (7). Secure axle shaft (11) in a vise and remove nut (3). Remove bull gear (4) and differential gear shaft (13) as a unit. Tap axle shaft out of housing being careful not to damage shaft. Remove bearings (9) and oil seal (10).

Inspect all parts for wear or other damage and renew as necessary. Maximum allowable backlash between drive gear (13) and bull gear (4) is 0.5 mm (0.020 inch).

When reassembling final drive, be sure to install oil seal (10) with lip facing

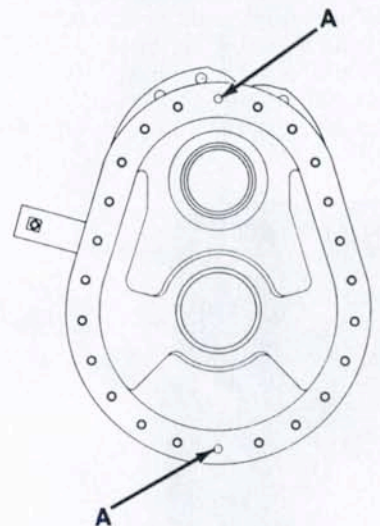

Fig. 136—When reassembling cover to axle case, tighten alignment bolts (A) first, then tighten remainder of mounting cap screws.

inward and lubricate seal lip with grease before reinstalling axle shaft. Differential gear shaft and bull gear must be

reinstalled at the same time. Tighten axle nut (3) to a torque of 196-245 N·m (145-180 ft.-lbs.), then stake nut after

tightening. Tighten axle cover alignment bolts (A—Fig. 136) first, then tighten remainder of cover cap screws evenly to a torque of 48-56 N·m (36-41 ft.-lbs.).

Models L295-L305-L345-L355

104. OVERHAUL. To disassemble final drive, first separate axle case (1—Fig. 139) from cover (11). Secure axle shaft in a vise, then remove bearing (4) and nut (5). Withdraw bull gear (6) and pinion gear (17) together from cover. Tap axle shaft (13) out of cover being careful not to damage shaft. Remove bearings (10) and oil seal (12).

To reassemble final drive reverse the disassembly procedure. Be sure to lubricate oil seal lip with grease prior to reinstalling axle shaft. Tighten axle nut (5) to a torque of 245-295 N·m (180-215 ft.-lbs.). Tighten axle cover alignment bolts (A—Fig. 136) first, then tighten remainder of cover cap screws evenly to a torque of 54-59 N·m (40-43 ft.-lbs.).

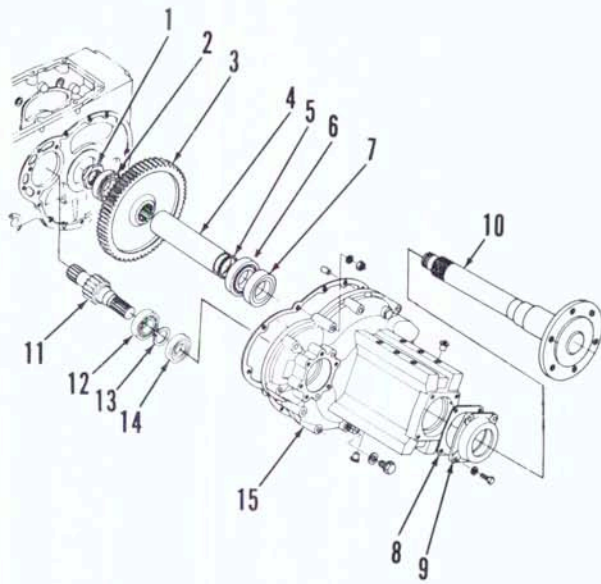

Fig. 137—Exploded view of final drive assembly used on Model L285.

1. Nut
2. Bearing
3. Bull gear
4. Sleeve
5. Washer
6. Bearing
7. Oil seal
8. Gasket
9. Seal retainer
10. Axle shaft
11. Differential gear shaft
12. Bearing
13. Snap ring
14. Oil seal
15. Axle housing

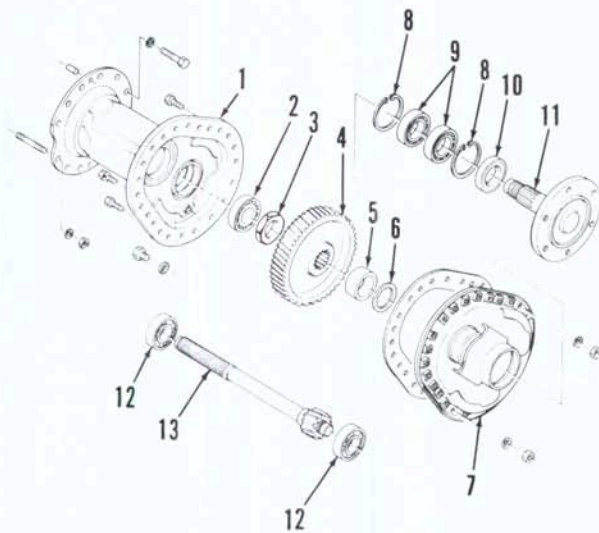

Fig. 138—Exploded view of final drive assembly used on Models L235 and L275.

1. Axle case
2. Bearing
3. Nut
4. Bull gear
5. Spacer
6. Shim
7. Cover
8. Snap ring
9. Bearings
10. Oil seal
11. Axle shaft
12. Bearings
13. Differential gear shaft

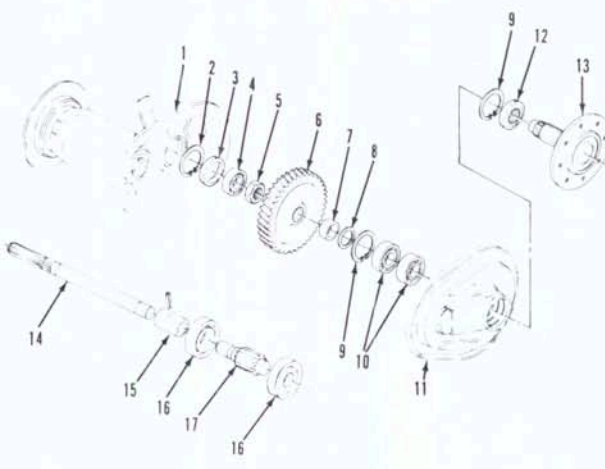

Fig. 139—Exploded view of final drive assembly used on Models L305 and L345. Models L295 and L355 are similar except a single axle shaft outer bearing (1) is used on Model L295 and plug (3) and snap ring (2) are not used on either model.

1. Axle case
2. Snap ring
3. Plug
4. Bearing
5. Nut
6. Bull gear
7. Spacer
8. Washer
9. Snap rings
10. Bearings
11. Cover
12. Oil seal
13. Axle shaft
14. Differential shaft
15. Coupling
16. Bearings
17. Bull pinion gear

BRAKES

ADJUSTMENT

All Models

105. Brake pedal free travel, measured at top of pedals (Fig. 140), should be approximately 30 mm (1-3/16 inches). Difference between right and left pedal free play must not exceed 5 mm (3/16 inch).

To adjust pedal free travel, loosen brake rod jam nuts and adjust turnbuckle (8—Fig. 141) to obtain desired pedal free travel. Be sure both pedals are adjusted equally.

R&R AND OVERHAUL

All Models Except L285

106. To remove disc brake assembly, first remove final drive assembly as



Fig. 140—Adjust brake pedal linkage to obtain approximately 30 mm (1-3/16 inches) pedal free travel.

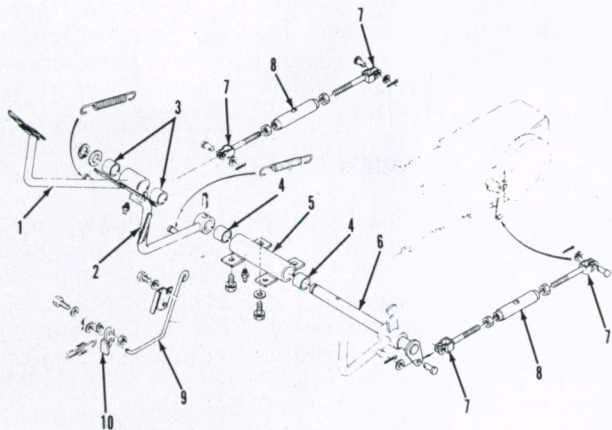

Fig. 141—Exploded view of typical brake control linkage.

1. Pedal R.H.
2. Pedal L.H.
3. Bushings
4. Bushings
5. Shaft support
6. Pedal shaft
7. Brake rods
8. Turnbuckle
9. Park brake rod
10. Park brake ratchet

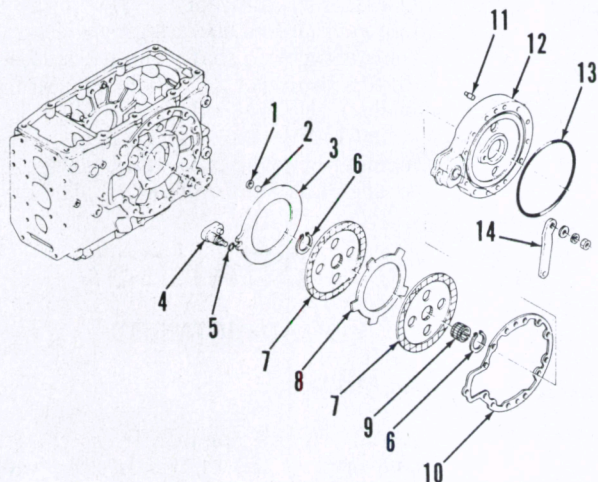

Fig. 142—Exploded view of internal, wet, disc type brake assembly used on Models L235, L245, L275, L295, L305, L345 and L355. Model L185 brake is similar except a single brake disc (7) is used. Model L285 brake is shown in Fig. 145.

1. Ball seat
2. Ball
3. Cam plate
4. Cam
5. "O" ring
6. Snap ring
7. Brake disc
8. Brake plate
9. Splined sleeve
10. Gasket
11. Dowel
12. Brake housing
13. "O" ring
14. Brake cam lever

operation. If cam (4) binds, remove and clean. Be sure to renew "O" ring (5). Check cam plate flatness (Fig. 143) using a surface plate and feeler gage. If a 0.3 mm (0.012 inch) feeler gage can be inserted between surface plate and machined surface of cam plate, renew cam plate. Measure thickness of cam plate with a ball installed as shown in Fig. 144. If thickness is less than 20.6 mm (0.811 inch), renew cam plate. Minimum allowable thickness of brake disc is 4.2 mm (0.165 inch). Minimum allowable brake plate thickness is 2.1 mm (0.083 inch).

To reinstall brake assembly, reverse the removal procedure. Apply coating of grease to balls (2 - Fig. 142) and seats (1) to hold them in place. Be sure brake cam plate fits snugly onto the four projections of differential bearing case. Renew brake housing "O" ring (13). Adjust brake pedal free travel as previously outlined.

Model L285

107. To remove brake assembly, disconnect brake rod and remove brake cover (12 - Fig. 145). Remove outer snap ring (9) and withdraw brake drum (10). Remove brake shoes (7) and return spring (8). Unbolt and remove anchor plate (5) and retaining ring (6) and withdraw brake cam (2). To renew brake pinion shaft oil seal, carefully pry old seal out of final drive case. Lubricate lip of new seal with grease, then install over pinion shaft being careful not to damage seal lip.

Brake shoes (7) should be renewed when lining is worn to within 0.3 mm (0.012 inch) of rivet heads. Maximum allowable inside diameter of brake drum is 147 mm (5.79 inches). Check operation of cam and clean and polish rotating surfaces as needed. Renew "O" ring (4) and gasket (1).

To reinstall brake, reverse the removal procedure. Adjust brake pedal free travel as outlined in paragraph 105.

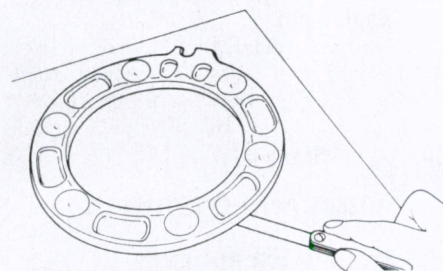

Fig. 143—Check flatness of brake cam plate using a feeler gage and surface plate.

outlined in paragraph 100. Disconnect brake rod from brake cam lever, then remove brake housing assembly, balls (2 - Fig. 142) and seats (1) from rear housing. Separate cam plate (3), brake discs (7) and plate (8) from brake housing (12).

Inspect all parts for excessive wear or other damage and renew as necessary. Move cam lever (14) by hand to check

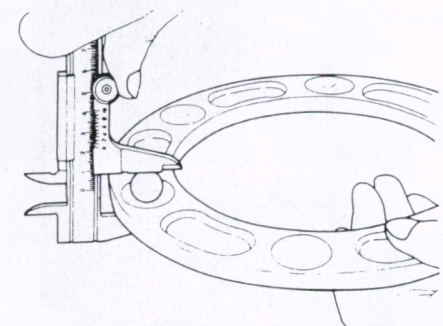
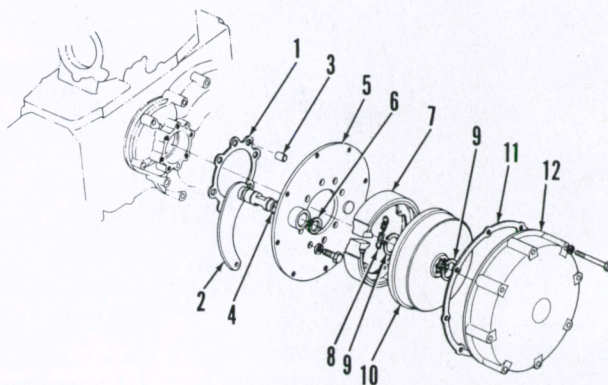

Fig. 144—Measure cam plate thickness with a ball installed as shown. Refer to text.

Fig. 145—Exploded view of external, dry, drum and shoe type brake used on Model L285.

1. Gasket
2. Cam Assy.
3. Dowel
4. "O" ring
5. Anchor plate
6. Snap ring
7. Brake shoes
8. Return spring
9. Snap ring
10. Brake drum
11. Gasket
12. Cover



POWER TAKE-OFF

Models L185-L245-L285-L295

108. REMOVE AND REINSTALL.

Procedure for removing pto countershaft is outlined in paragraph 71 for Models L185, L245 and L295 and in paragraph 72 for Model L285. Removal procedure for pto output shaft is given paragraph 75 for Models L185, L245 and L295 and in paragraph 76 for Model L285. Refer to paragraph 68 for removal and overhaul of pto shift linkage on all models.

109. OVERRUNNING CLUTCH.

An overrunning clutch assembly is used to transmit power from pto countershaft to output shaft. Overrunning clutch allows pto output shaft to continue to turn without driving tractor forward when clutch is depressed. Overrunning

clutch can be removed after splitting tractor between front and rear transmission housings.

A sprag-type overrunning clutch (Fig. 146) is used on Models L185, L245 and L285. With clutch installed on pto countershaft, clutch case (7) and rear coupling (8) should turn freely and smoothly in a clockwise direction but should not turn counterclockwise. If trouble is experienced, disassemble unit and examine internal clutch surface of case and outer surface of front coupling (3) for ridging or scoring. Renew components if damage is found. Be sure new sprag unit (4) is reinstalled correctly as engaging action will be reversed if sprag unit is reversed. Check for correct rotation as previously outlined when unit is reassembled.

A simple, spring-loaded, cam-type clutch (4-Fig. 147) is used on Model L295. Service consists of renewing worn parts. Clutch cams are interchangeable.

Models L235-L275

110. REMOVE AND REINSTALL.

Procedure for removal of pto countershaft and gears is outlined in paragraph 82. Removal of pto output shaft is covered in paragraph 86.

Removal of pto shift linkage requires removal of front transmission housing as outlined in paragraph 81. Unbolt and lift off pto shift plate (3-Fig. 148 or 149). Remove main shifter housing. Drive spring pins out of shift rail holder (5) and shift arm (7), then push shift rail (6) out of shifter housing. Remove set screw (14-Fig. 148) or plug (17-Fig. 149) and detent ball (16). Drive spring pins out of shift fork (11-Fig. 149), then remove shift rail and fork.

To reinstall pto shift linkage, reverse the removal procedure.

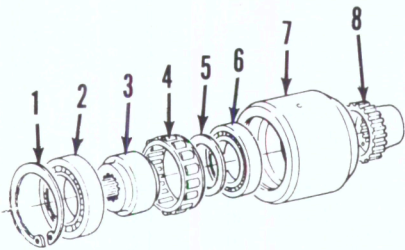

Fig. 146—Exploded view of pto overrunning clutch used on Models L185 and L285. Model L245 is similar except washer (5) and splined coupling (8) are not used.

- | | |
|-------------------|------------------|
| 1. Snap ring | 5. Washer |
| 2. Bearing | 6. Bearing |
| 3. Front coupling | 7. Clutch case |
| 4. Sprag clutch | 8. Rear coupling |

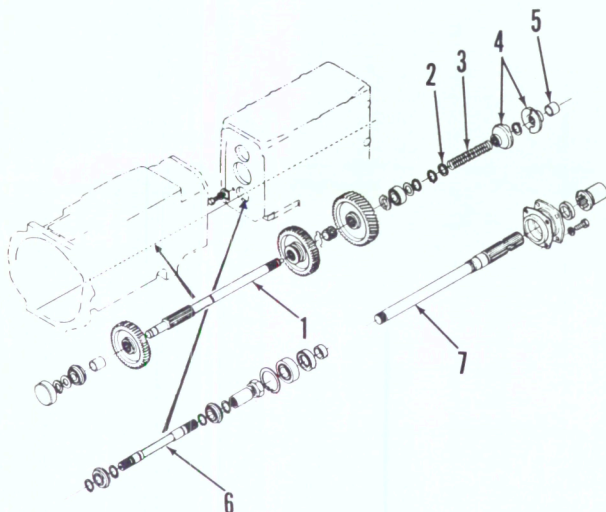

Fig. 147—Exploded view of pto countershaft, overrunning clutch and pto output shaft used on Model L295. Models L235 and L275 equipped with single plate engine clutch use a similar style overrunning clutch.

- | |
|---------------------|
| 1. Pto countershaft |
| 2. Washer |
| 3. Spring |
| 4. Clutch arms |
| 5. Spacer |
| 6. Pto drive shaft |
| 7. Pto output shaft |

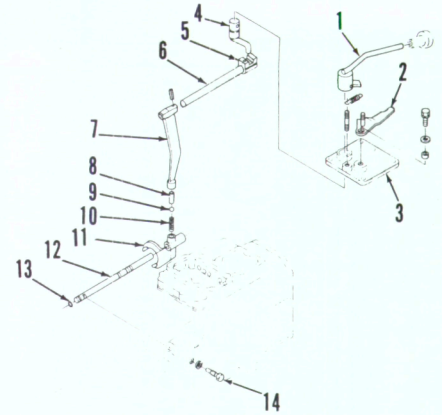

Fig. 148—Exploded view of pto shift linkage used on Models L235 and L275 equipped with single plate engine clutch.

- | | |
|-----------------|----------------|
| 1. Shift handle | 8. Pin |
| 2. Check lever | 9. Ball |
| 3. Shift plate | 10. Spring |
| 4. Shift lever | 11. Shift fork |
| 5. Rail holder | 12. Rail |
| 6. Shift rail | 13. "O" ring |
| 7. Shift arm | 14. Set screw |

111. OVERRUNNING CLUTCH.

Models L235 and L275 equipped with a single plate engine clutch use an overrunning clutch similar to the one shown in Fig. 147. Clutch service consists of renewing worn parts. Clutch cams (4) are interchangeable.

Models L305-L345

112. REMOVE AND REINSTALL.

Procedure for removing pto countershaft is given in paragraph 73 and pto

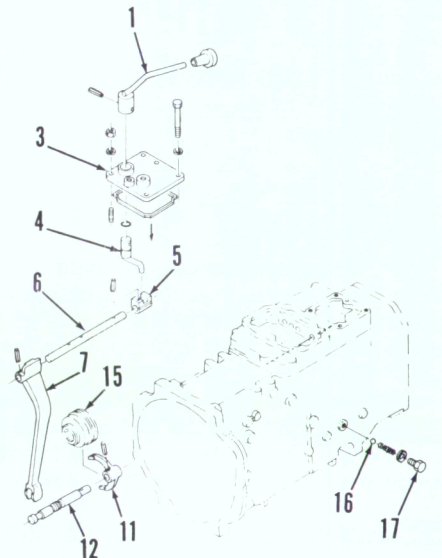

Fig. 149—Exploded view of pto shift linkage used on Models L235 and L275 equipped with dual stage engine clutch. Refer to Fig. 148 legend except for the following:

- | | |
|------------------|----------|
| 15. Shift collar | 17. Plug |
| 16. Detent ball | |

TROUBLESHOOTING

All Models

115. The following are problems which may occur during the operation of hydraulic lift system. Use this information in conjunction with Test and Adjust information when servicing hydraulic lift system.

1. Hitch will not lift load. Could be caused by:
 - a. Control linkage damaged.
 - b. Control valve improperly adjusted.
 - c. Relief valve defective or set too low.
 - d. Insufficient transmission oil or filter plugged.
 - e. Unloading valve in main control valve defective.
 - f. Drop poppet valve in main control valve leaking.
 - g. "O" ring seals on main control valve damaged.
 - h. Faulty hydraulic pump.
 - i. Lift cylinder or piston damaged or piston "O" ring faulty.
2. Hitch will not raise fully. Could be caused by:
 - a. Feedback rod improperly adjusted.
 - b. Control valve improperly adjusted.
3. Hitch will not lower or lowers too slowly. Could be caused by:
 - a. Drop poppet valve misadjusted.
 - b. Drop speed valve misadjusted.
4. Hitch will not maintain position.

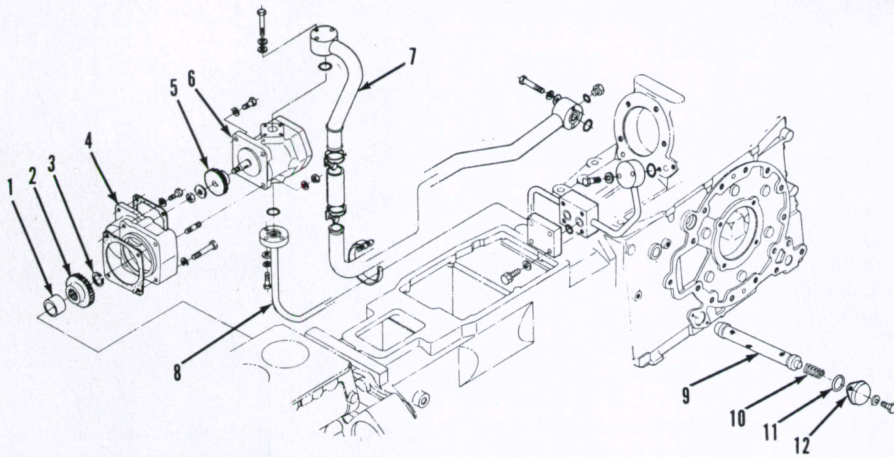

Fig. 150—Exploded view of hydraulic pump drive, pipes and hydraulic filter on Models L185 and L245.

- | | | |
|---------------------|-------------------|---------------|
| 1. Spacer | 5. Driven gear | 9. Filter |
| 2. Drive gear | 6. Pump assy. | 10. Spring |
| 3. Snap ring | 7. Suction tube | 11. "O" rings |
| 4. Mounting adapter | 8. Discharge tube | 12. Cover |

output shaft removal procedure is outlined in paragraph 77. Refer to paragraph 69 for removal of pto shift mechanism.

Model L355

113. REMOVE AND REINSTALL. Removal of pto countershaft is covered in paragraph 84 and removal of pto output shaft is outlined in paragraph 86. Refer to paragraph 80 for removal of pto shift mechanism.

cleaned after every 300 hours of operation.

On Models L235 and L275, a spin-on type hydraulic filter is located on top of hydraulic pump on inlet side. Filter (11—Fig. 151) should be renewed after every 300 hours of operation.

On Models L285, L295, L305, L345 and L355, hydraulic filter (13—Fig. 152) is located in filter case (14) on inlet side of hydraulic pump. Filter element should be cleaned after every 300 hours of operation. Be sure to renew element if damaged.

HYDRAULIC SYSTEM

FLUID AND FILTER

All Models

114. Transmission and differential lubricant serves as hydraulic fluid and the transmission housing is fluid reservoir. Recommended oil is Kubota UDT hydraulic fluid. Refer to "Condensed Service Data" specifications section for reservoir capacities.

NOTE: Early "L" series tractors contained SAE 80 gear oil in transmission housing. Gear oil should be drained and UDT fluid installed if not already done.

Transmission and hydraulic fluid should be drained and renewed after every 300 hours of operation.

On Models L185 and L245, an intake strainer is located in lower left section of rear transmission housing. Strainer (9—Fig. 150) should be removed and

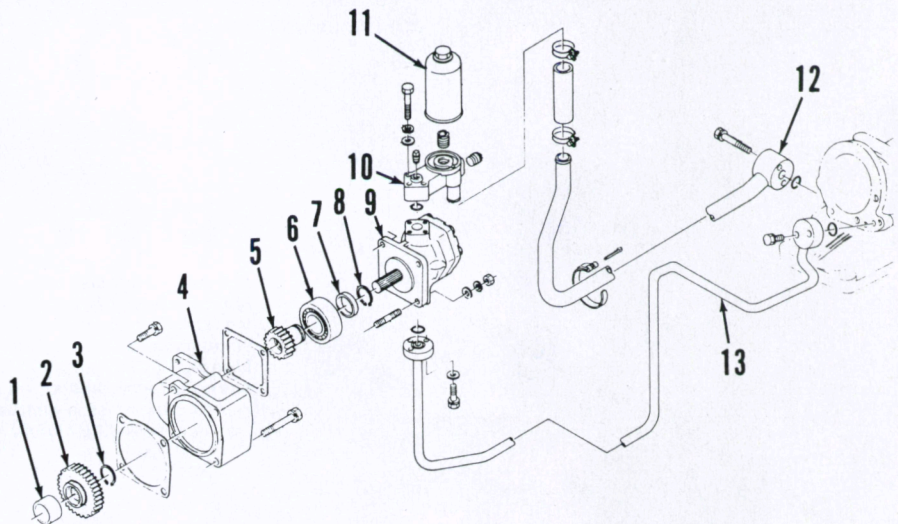

Fig. 151—Exploded view of hydraulic pump drive, pipes and filter used on Models L235 and L275.

- | | | |
|---------------------|----------------|--------------------|
| 1. Spacer | 5. Driven gear | 10. Filter housing |
| 2. Drive gear | 6. Bearing | 11. Filter |
| 3. Snap ring | 7. Spacer | 12. Suction tube |
| 4. Mounting adapter | 8. Snap ring | 13. Discharge tube |
| | 9. Pump assy. | |

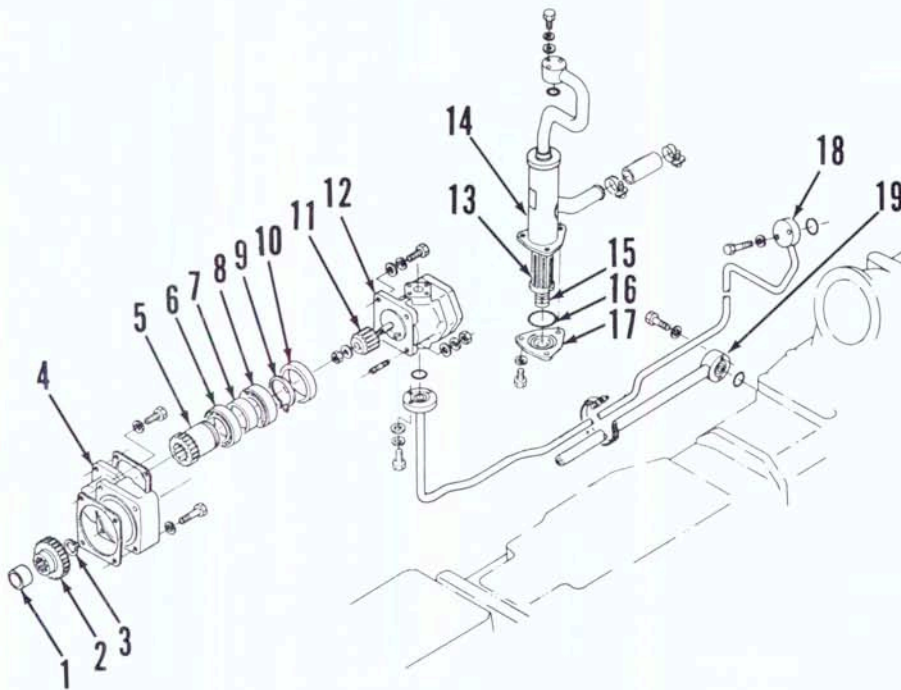

Fig. 152—Exploded view of hydraulic pump drive, pipes and filter used on Models L285, L295, L305, L345 and L355.

- | | | |
|---------------------|-----------------|--------------------|
| 1. Spacer | 7. Inner race | 14. Filter case |
| 2. Drive gear | 8. Ball bearing | 15. Spring |
| 3. Snap ring | 9. Snap ring | 16. "O" ring |
| 4. Mounting adapter | 10. Spacer | 17. Cover |
| 5. Driven gear | 11. Pump gear | 18. Discharge pipe |
| 6. Needle bearing | 12. Pump Assy. | 19. Suction pipe |
| | 13. Filter | |

Could be caused by:

- a. Hydraulic cylinder or piston worn or damaged, or piston "O" ring damaged.
 - b. Drop check valve in main control valve leaking.
 - c. Drop poppet valve in main control valve leaking.
5. Hydraulic system stays on high pressure. Could be caused by:
- a. Linkage misadjusted or broken.
6. Draft control (if equipped) malfunction. Could be caused by:
- a. Draft control linkage misadjusted or broken.

- b. Position control lever not in LIFT position.
- c. Draft control valve spool worn or damaged.
- d. Torsion bar broken.

TEST AND ADJUST

Prior to performing hydraulic tests, be sure hydraulic fluid level is correct and hydraulic filter is in satisfactory condition. Hydraulic fluid should be at normal operating temperature of 40°-50° C (100°-120° F) when testing and adjusting hydraulic system.

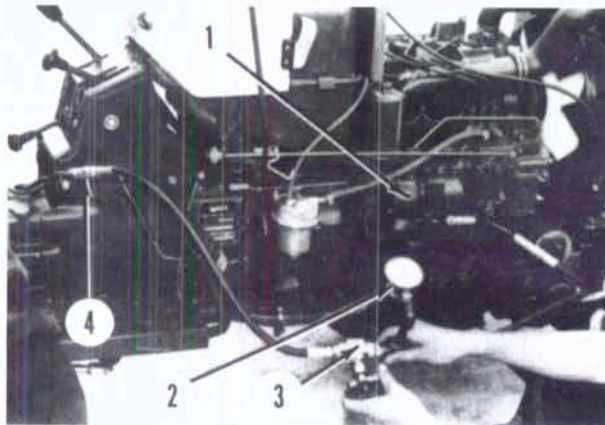

Fig. 153—Connect pressure gage (2) and flow control valve (3) to pump discharge port (1) to check pump pressure. Refer to text.

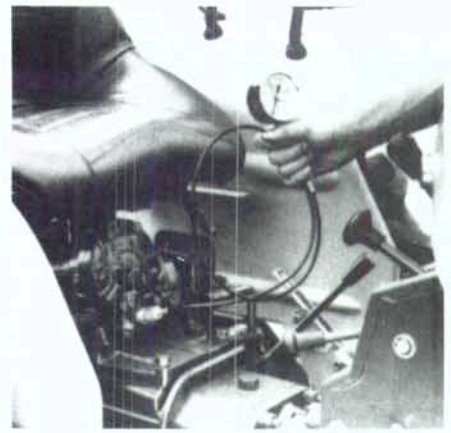

Fig. 154—Connect pressure gage into pressure test port in hydraulic cylinder cover to check and adjust relief valve pressure setting.

All Models

116. PUMP DISCHARGE PRESSURE. To isolate pump from hydraulic system and check pump discharge pressure, proceed as follows: Disconnect discharge pipe from pump and install a pressure gage and flow control valve as shown in Fig. 153. Place pressure gage return hose into reservoir filler opening.

CAUTION: With test equipment connected as outlined, pressure relief valve will be eliminated. Be sure flow control valve is fully open before starting engine. Do not continue to close flow control valve after specified pressure is reached. Otherwise, pump damage will occur.

With hydraulic fluid at operating temperature and engine operating at high idle speed, slowly close flow control valve until specified pump pressure of 13240-14690 kPa (1920-2130 psi) is obtained. If specified pump pressure cannot be obtained, remove and overhaul or renew pump.

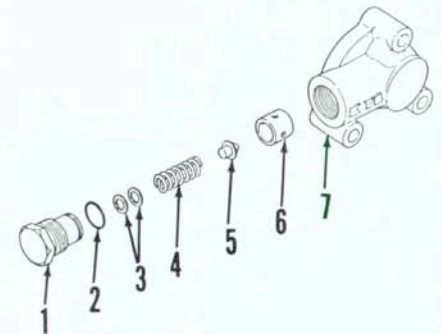

Fig. 155—Exploded view of hydraulic system relief valve assembly. Pressure setting is adjusted with shims (3).

- | | |
|-------------|-----------|
| 1. Plug | 5. Poppet |
| 2. "O" ring | 6. Seat |
| 3. Shims | 7. Body |
| 4. Spring | |

117. SYSTEM PRESSURE.

Hydraulic system relief pressure should be 13240-14690 kPa (1920-2130 psi) on all models. To check relief pressure, remove plug from test port in hydraulic cylinder cover and install a pressure gage as shown in Fig. 154. Disconnect linkage feedback rod (1 - Fig. 156) and remove position control lever upper stop. With hydraulic fluid temperature at approximately 40°C (100°F) and engine operating at high idle speed, move draft control lever (if equipped) and position control lever to highest positions and note pressure gage reading when relief valve is actuated. If pressure is not within specified limits, remove plug (1 - Fig. 155) from relief valve assembly and add or remove shims (3) to obtain desired pressure relief setting. Reconnect and adjust linkage feedback rod as outlined in following paragraph.

118. LINKAGE ADJUSTMENT.

To adjust position control feedback rod, start engine and move position control lever to "LIFT" position. Shorten feedback rod (Fig. 156) until relief valve is actuated, then lengthen rod one full turn and tighten locknut. Operate position control lever from full down position to full up position to make sure relief valve is not actuated.

To adjust draft control (if so equipped), attach a weight of approximately 10 kg (20 pounds) to hitch lower links. Place position control lever in "LIFT" position and draft control lever in "DOWN" position. Operate engine at rated speed and use a test bar (Fig. 157) to lift top link holder all the way forward. Hitch should start to raise when draft control lever is moved to "1" marking on lever guide. Adjust length of draft control rod (3 - Fig. 158), if necessary, to obtain recommended draft control operation.

Fig. 157—Use a test bar to lift top link holder fully forward when adjusting draft control linkage.

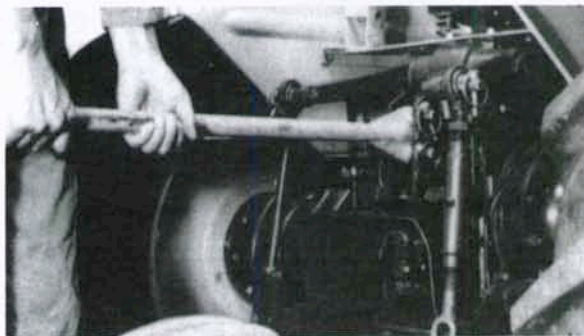

Fig. 158—Adjust length of draft control rod (3) so hitch starts to raise when draft control lever (1) aligns with "1" marking on lever guide.

1. Draft control lever
2. Locknut
3. Draft control rod

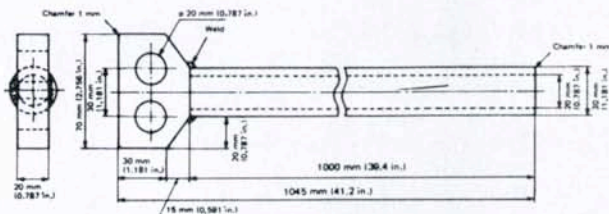
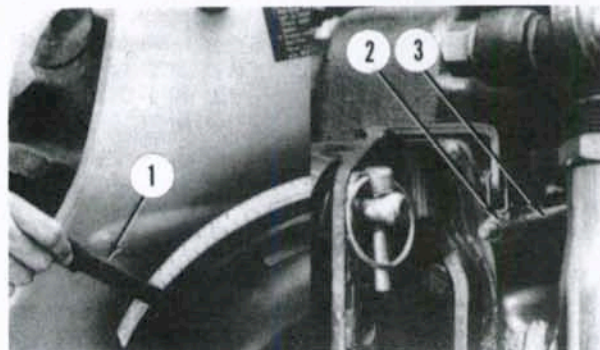

Fig. 159—Dimensions for test bar used in draft control adjustment.

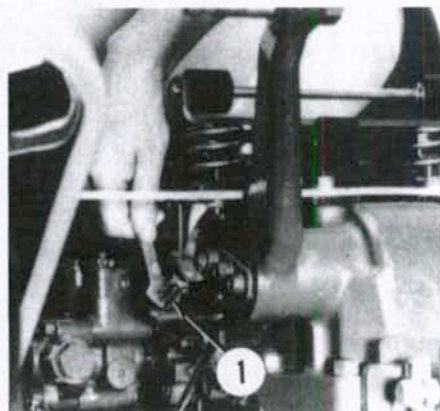

Fig. 160—Exploded view of typical hydraulic pump used on Models L185, L235, L245, L285 and L295.

1. Retaining ring
2. Oil seal
3. Body
4. "O" rings
5. Bushings
6. Key
7. Driven gear
8. Drive gear
9. "O" ring
10. End cover
11. "O" ring

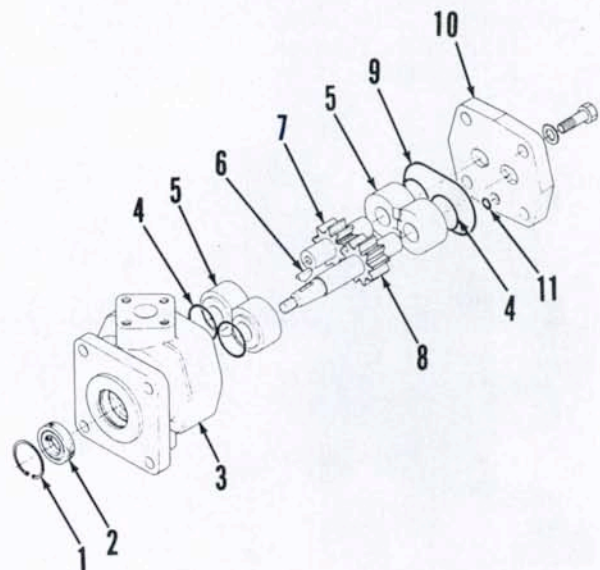

Fig. 156—View of position control feedback rod adjustment on Model L275. Other models are similar. Refer to text for adjustment procedure.

NOTE: Test bar can be fabricated using dimensions given in Fig. 159.

Use a spring scale attached at top of control lever to check control lever friction adjustment. It should require 1.5-3.5 kg (3.4-7.5 pounds) to move control lever. To adjust, tighten or loosen control lever shaft nut.

PUMP

Models L185-L235-L245-L275-L285-L295

119. R&R AND OVERHAUL. Gear-type hydraulic pump is mounted on right side of engine and gear driven from rear of injection pump camshaft. To remove pump, disconnect suction and discharge pipes from pump. Remove pump mounting cap screws and stud nuts, then slide pump rearward off drive housing. Cover suction and discharge pipe openings to prevent entry of dirt.

To disassemble pump, remove retaining nut and drive gear on Models L185 and L245. On all models, scribe a match mark across end cover and pump body to ensure correct reassembly. Remove end cover mounting screws, then carefully separate cover and components as shown in Fig. 160. Be sure to identify location of bushings (5) and driven gear (7) so they can be reinstalled in their original positions. Bushings should not be interchanged. Remove oil seal (2) from pump body and discard all seal rings.

Radial clearance between tip of gear tooth and inside diameter of pump body should not exceed 0.05 mm (0.002 inch) on Models L185, L245, L285 and L295 or 0.15 mm (0.006 inch) on Models L235 and L275. Renew pump if clearance is excessive. Maximum allowable clearance between bushings (5) and gear shafts is 0.18 mm (0.007 inch) on Models L185, L245, L285 and L295 or 0.12 mm

Fig. 162—Exploded view of front and rear hydraulic pump sections used on Models L345 and L355 equipped with power steering.

1. End cover
2. "O" ring
3. Back-up ring
4. Seal ring
5. Bushings
6. Drive gear
7. Driven gear
8. "O" ring
9. Body
10. Oil seal
11. Drive coupling
12. "O" ring
13. Adapter plate
14. "O" ring
15. Center plate
16. Body seal
17. Bushing seal
18. Gasket rings
19. Bushings
20. Driven gear
21. Drive gear
22. Body
23. Mounting flange
24. Oil seal

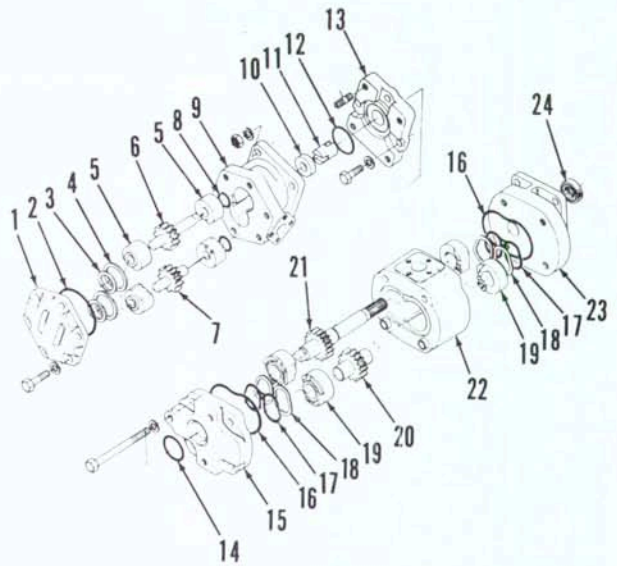

(0.005 inch) on Models L235 and L275. Bushing length should not be less than 18.67 mm (0.735 inch) on Models L185, L245, L285 and L295 or 18.8 mm (0.74 inch) on Models L235 and L275. Be sure surfaces of bushings are not scored or pitted and gear shafts rotate smoothly in bushings.

When reassembling pump, lubricate all parts with clean hydraulic oil during assembly. Be sure to renew all seal rings. Tighten cover mounting screws evenly to a torque of 32-39 N·m (24-29 ft. -lbs.).

When reinstalling pump, attach discharge line to pump first. Fill pump with clean oil through inlet opening, then install inlet line. Use grease to hold "O" rings in place when reinstalling hydraulic pipes.

Models L305-L345-L355

120. R&R AND OVERHAUL. Tandem, gear-type hydraulic pumps are used on Models L345 and L355 equipped

with power steering. Rear pump section supplies power steering and front pump section supplies hydraulic lift. A single, gear-type pump is used on Model L345 equipped with manual steering and all L305 tractors. On Model L305, a flow divider valve provides a priority supply of oil to power steering and remainder of pump flow is directed to hydraulic lift. On all models, hydraulic pump is mounted on right side of engine and gear driven from rear of injection pump camshaft.

To remove pump assembly, disconnect inlet and discharge tubes from pump body. Remove mounting bolts and nuts, then withdraw pump assembly rearward from engine. Scribe a match mark across pump body and cover to ensure correct reassembly. Separate rear section (1—Fig. 161) and drive coupling (2) from front pump section (4) on tandem pumps.

To disassemble rear pump section (if so equipped), remove end cover (1—Fig. 162). Remove drive gear (6) and driven

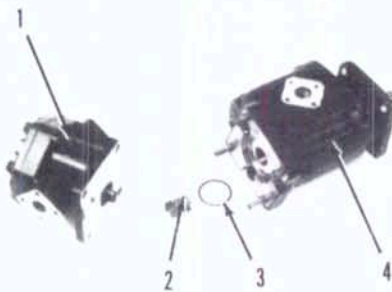
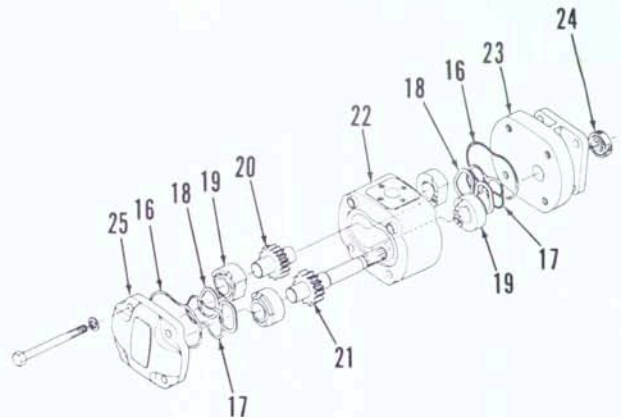

Fig. 161—Rear pump section (1) supplies power steering and front pump section (4) supplies hydraulic lift on Model L345 (with power steering) and L355.

1. Rear pump section
2. Drive coupling
3. "O" ring
4. Front pump section

Fig. 163—Exploded view of single hydraulic pump used on model L305. Pump used on Model L345 equipped with manual steering is similar. Except for end cover (25), refer to Fig. 162 legend.



gear (7) from body and separate components as shown. Be sure to identify bushings (5) so they can be reinstalled in their original positions. Drive oil seal (10) out of body (9).

To disassemble front pump, remove adapter plate (13—Fig. 162) and center plate (15) on tandem pumps. On single pump, remove end cover (25—Fig. 163). On all models, push gears and bushings from body. Identify bushings so they can be reinstalled in their original positions. Drive oil seal (24—Fig. 162 or 163) out of mounting flange (23). Discard all “O” rings and seal rings.

Inspect all parts for excessive wear, scoring or other damage. Inside diameter of pump body should not exceed 39.575 mm (1.558 inches) on front pump and 31.088 mm (1.2239 inches) on rear pump. Clearance between bushings and gear shafts should not exceed 0.188 mm (0.0074 inch) on front pump and 0.177 mm (0.0069 inch) on rear pump section. Minimum allowable bushing length is 18.92 mm (0.745 inch) on front pump and 18.67 mm (0.735 inch) on rear pump. Renew all “O” rings and seal rings.

When reassembling pump sections, lubricate all parts with clean hydraulic oil. Tighten center plate (15) mounting cap screws to a torque of 46-49 N·m (34-36 ft.-lbs.) Tighten adapter plate (13) mounting screws to a torque of 26-32 N·m (19-24 ft.-lbs.). Tighten rear pump end cover (1) cap screws to a torque of 26-32 N·m (19-24 ft.-lbs.).

Reinstall pumps and connect discharge hydraulic pipes. Fill pump bodies with clean hydraulic oil, then connect inlet pipes.

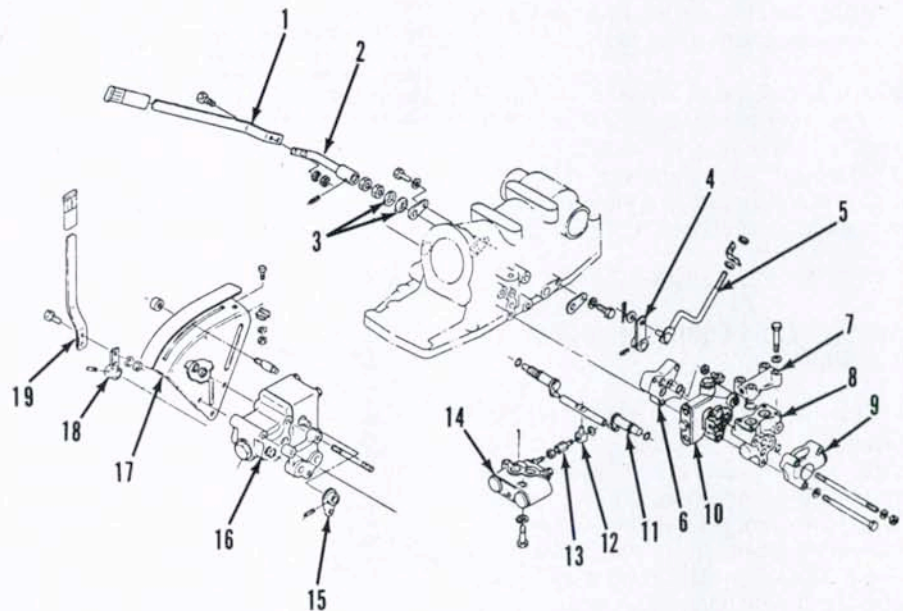
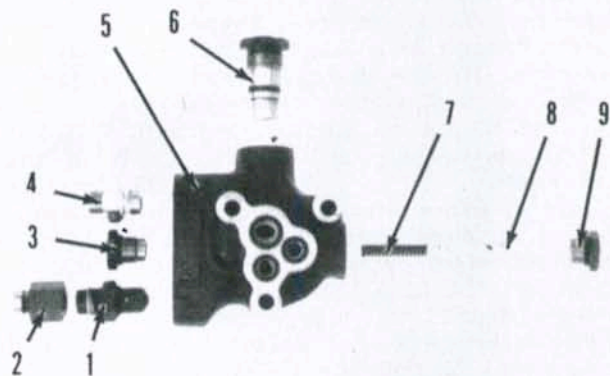

Fig. 164—View of hydraulic valves and operating linkage. Flow priority valve (10) is not used on all models.

- | | | | |
|----------------------------|-----------------------|----------------------------|--------------------------|
| 1. Position control handle | 5. Feedback rod | 10. Flow priority valve | 15. Feedback lever |
| 2. Control lever | 6. Spacer block | 11. Control arm | 16. Draft control valve |
| 3. Spring washers | 7. Block cover | 12. Joint | 17. Lever guide |
| 4. Feedback lever | 8. Oil pressure block | 13. Turnbuckle | 18. Control lever |
| | 9. Relief valve Assy. | 14. Position control valve | 19. Draft control handle |

Fig. 165—View of disassembled flow priority valve used on some models.

1. Connector
2. Connector
3. Plug
4. Connector
5. Valve body
6. Plug
7. Spring
8. Spool
9. Plug



HYDRAULIC VALVES

All Models

121. RELIEF VALVE. Hydraulic system relief valve (9—Fig. 164) is mounted on left side of rockshaft housing. Pressure relief setting is adjusted by adding or removing shims (3—Fig. 155). Refer to paragraph 117 for pressure test procedure. When reinstalling valve assembly, tighten through-bolt to a torque of 78-90 N·m (58-66 ft.-lbs.).

Models So Equipped

122. FLOW PRIORITY VALVE. A flow divider valve (10—Fig. 164) is used on Models L235 and L275 equipped with power steering and all Models L305 and L355. Flow divider valve is mounted on left side of rockshaft housing. To disassemble valve, remove plugs and push valve spool (8—Fig. 165) and spring out of valve body. If spool or valve

Fig. 166—Cross-sectional view of position control valve.

1. Valve spool
2. Pump port
3. Unloading valve
4. Drop check valve
5. Cylinder port
6. Poppet valve

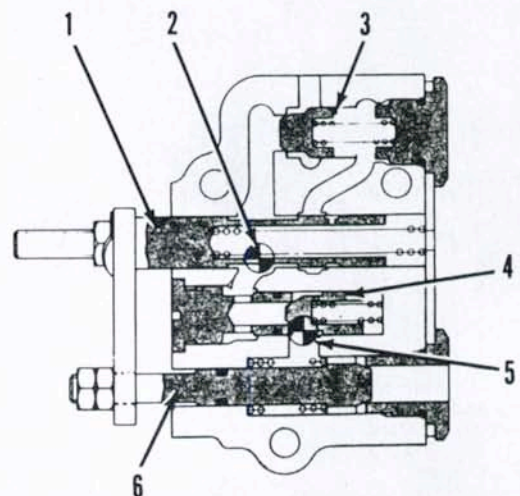

bore is worn or damaged, complete valve assembly must be renewed.

POSITION CONTROL VALVE

All Models

123. The position control valve (Fig. 166) controls up and down movement of hydraulic hitch. Valve spool (1) is moved to direct oil to lift cylinder. A poppet valve (6) is opened to return oil to reservoir when hitch is lowered. An unloading valve (3) allows oil from pump to return to reservoir when control valve is in neutral. A drop check valve (4) maintains oil pressure in hydraulic cylinder until pump pressure is suffi-

cient to raise load on hitch.

124. **R&R AND OVERHAUL.** Position control valve (14—Fig. 164) is mounted on bottom of rockshaft housing. To remove valve, first remove rockshaft housing as outlined in paragraph 127. Remove valve mounting cap screws and lift off valve housing. Do not disturb valve spool adjustment unless necessary.

Before disassembling valve, move plate (Fig. 167) against valve body and measure and record distance between plate and poppet valve locknut. When reassembling valve, install locknut to same dimension. Remove nuts from poppet valve (18—Fig. 168). Withdraw valve spool (2) and plate (1). Remove plugs (9 and 20), plate (14) and unloading valve (6). Pull poppet valve (18) and spring (17) from valve body. Unscrew check valve seat (10) and remove check valve (12) and spring (13).

Inspect all parts for excessive wear or other damage and renew as necessary. Renew all "O" rings. Be sure to coat all parts with clean hydraulic oil during reassembly.

When reassembling valve, tighten check valve seat (10) to a torque of 49-59 N·m (36-43 ft.-lbs.). Be sure "O" ring (16) and back-up ring (15) are correctly positioned on poppet valve. Tighten plugs (9 and 20) to a torque of 69-88 N·m (50-65 ft.-lbs.). Install poppet valve locknuts to same dimension as measured prior to disassembly (Fig. 167). To adjust poppet valve lower nut until it contacts plate, then loosen nut 1/2-turn and lock in place with jam nut.

Reinstall valve assembly onto rockshaft housing. Tighten valve mounting cap screws to a torque of 18-23 N·m (13-17 ft.-lbs.). Adjust control valve spool as follows: Measure distance between plate (Fig. 169) and control valve spool joint end. If distance is not within 69.0-69.5 mm (2.717-2.736 inches) on Models L235 and L275 or 59.5-60.5 mm (2.342-2.382 inches) on all other models, loosen locknut and adjust turnbuckle to obtain recommended dimension.

DRAFT CONTROL VALVE

Models So Equipped

125. The draft control valve is mounted on right side of rockshaft housing. Hitch load sensing is transmitted through a torsion bar and linkage to draft control valve. The valve automatically raises or lowers hitch to maintain a constant load on hitch.

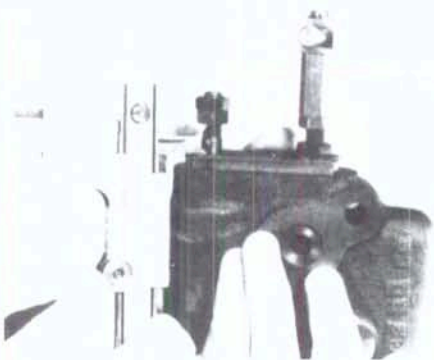

Fig. 167—Measure distance from plate to poppet locknut before disassembling valve. Record measurement for use in reassembly.

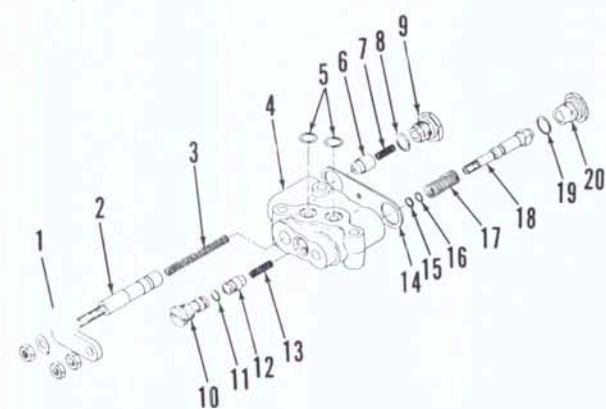

Fig. 168—Exploded view of position control valve assembly.

1. Plate
2. Valve spool
3. Spring
4. Valve body
5. "O" rings
6. Unloading valve
7. Spring
8. "O" ring
9. Plug
10. Seat plug
11. "O" ring
12. Check valve
13. Spring
14. Plate
15. Back-up ring
16. "O" ring
17. Spring
18. Poppet valve
19. "O" ring
20. Seat plug

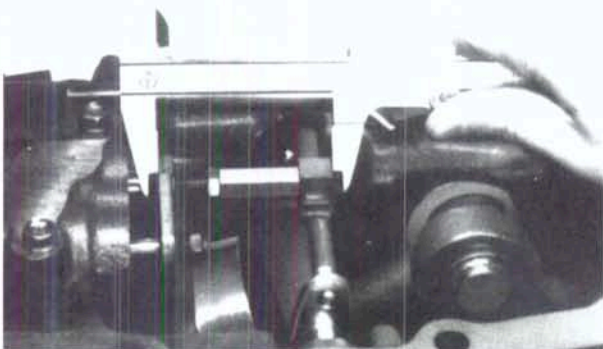

Fig. 169—Measure distance between plate and position control valve spool joint end as shown. Adjust by turning turnbuckle. Refer to text.

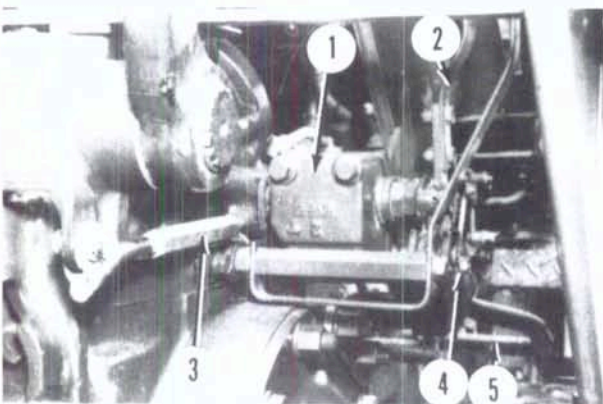

Fig. 170—Draft control valve (models so equipped) is mounted on right side of rockshaft housing.

1. Draft control valve
2. Control lever
3. Feedback rod
4. Bracket
5. Differential lock pedal

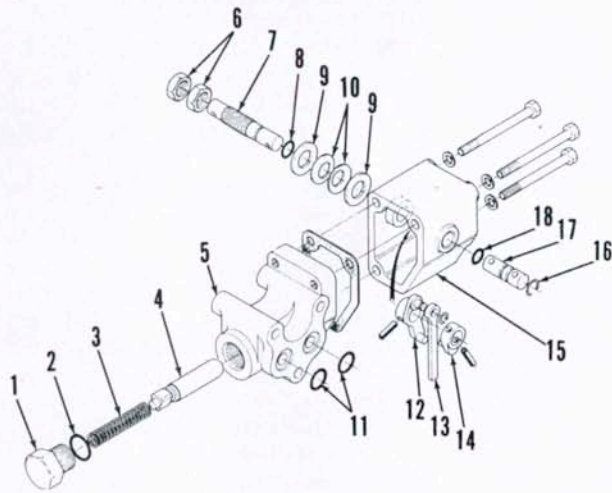

Fig. 171—Exploded view of draft control valve used on models so equipped.

1. Plug
2. "O" ring
3. Spring
4. Valve spool
5. Valve body
6. Nuts
7. Control lever shaft
8. "O" ring
9. Washers
10. Spring washers
11. "O" rings
12. Arm
13. Link
14. Arm
15. Case
16. Retaining ring
17. Control rod shaft
18. "O" ring

126. R&R AND OVERHAUL. To remove draft control valve (1 - Fig. 170), proceed as follows: Disconnect feedback rod (3) and remove control lever (2). Remove differential lock pedal (5) and bracket (4). Unbolt and remove valve assembly.

To disassemble valve, remove plug (1 - Fig. 171) and spring (3). Remove through-bolts and separate case (15) from valve body (5). Withdraw valve spool (4) from body. Drive out spring pins and remove shafts (7 and 17), arms

(12 and 14) and link (13).

Inspect all parts for excessive wear or other damage. Spool (4) must be free of scratches and move smoothly in valve bore. Valve spring free length should be approximately 49 mm (1-15/16 inches) and test 78.4 N (17.6 pounds) when compressed to a length of 41 mm (1-5/8 inches). Renew all "O" rings and lubricate with clean oil during reassembly.

Reassemble valve by reversing disassembly procedure. Tighten plug (1) to a torque of 59-69 N·m (45-50 ft.-lbs.).

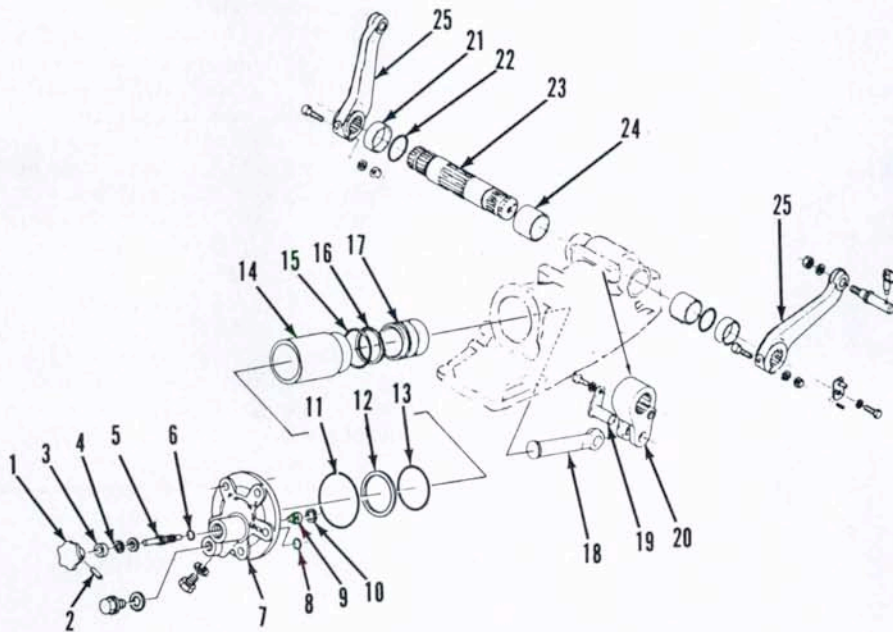

Fig. 172—Exploded view of rockshaft assembly and lift cylinder assembly used on all models.

- | | | |
|--------------------|---------------------|-------------------|
| 1. Knob | 9. Adjusting collar | 18. Piston rod |
| 2. Spring pin | 10. Snap ring | 19. Retaining pin |
| 3. Oil seal | 11. "O" ring | 20. Rockshaft arm |
| 4. Snap ring | 12. Back-up ring | 21. Spacer |
| 5. Adjusting screw | 13. "O" ring | 22. "O" ring |
| 6. "O" ring | 14. Cylinder liner | 23. Rockshaft |
| 7. Cylinder cover | 15. "O" ring | 24. Bushing |
| 8. "O" ring | 16. Back-up ring | 25. Lift arms |
| | 17. Piston | |

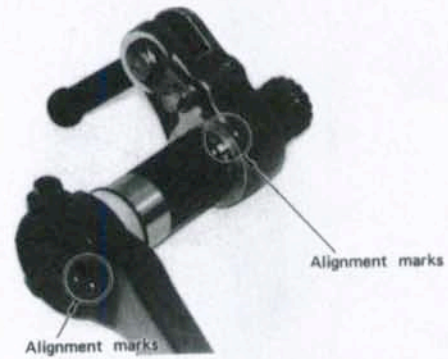

Fig. 173—Be sure to match alignment marks on rockshaft, rockshaft arm and lift arms.

ROCKSHAFT HOUSING

All Models

127. REMOVE AND REINSTALL. To remove rockshaft housing, disconnect hydraulic pipes and hitch lift links. Remove seat. Remove housing mounting cap screws, then lift rockshaft housing off transmission housing.

To reinstall rockshaft housing, reverse the removal procedure. Tighten housing mounting cap screws to a torque of 80-90 N·m (60-65 ft.-lbs.).

128. OVERHAUL. To remove hydraulic cylinder head (7 - Fig. 172), cylinder liner (14) or piston (17), first remove cylinder head mounting cap screws. Apply down pressure to lift arms to force off cylinder head. Cylinder liner and piston may come out with cylinder head. If they do not come out, hand push piston and liner out of housing.

To remove drop speed valve, drive out spring pin (2) and remove knob (1). Remove snap rings (4 and 10), then withdraw adjusting screw (5) and collar (9). Drive out oil seal (3).

To remove rockshaft and components, first be sure lift arms and shaft splines and rockshaft arm (Fig. 173) are punch marked for correct alignment at reassembly.

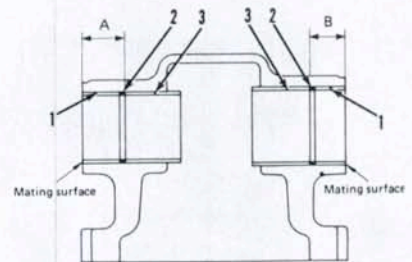

Fig. 174—When renewing rockshaft bushings, press bushings into housing bores to dimension "A" on right side and dimension "B" on left side.

- | | |
|---------------------------------------|-------------|
| A. 30.5-31.5 mm
(1.20-1.24 inches) | 1. Spacer |
| B. 26.5-27.5 mm
(1.05-1.08 inches) | 2. "O" ring |
| | 3. Bushing |

Remove retaining pin (19—Fig. 172), piston rod (18) and lift arms (25). Bump rockshaft (23) out right side of housing. Spacers (21), "O" rings (22) and bushings (24) can be removed at this time.

Inspect cylinder liner and piston for excessive wear, scoring or other damage. Renew cylinder liner if wear exceeds 0.15 mm (0.006 inch). Clearance between rockshaft and bushings should not exceed 0.5 mm (0.020 inch). Press new bushings (3—Fig. 174) into housing until 30.5-31.5 mm (1.20-1.24 inches) below outer surface (A) on right side and 26.5-27.5 mm (1.05-1.08 inches) below outer surface (B) on left side. Clearance between piston rod (18—Fig. 172) and pin (19) should not exceed 0.4 mm (0.016 inch).

Fig. 175—Install back-up rings and "O" rings on piston (5) and cylinder head (1) as shown.

1. Cylinder head
2. "O" ring
3. Back-up ring
4. "O" ring
5. Piston
6. "O" ring
7. Back-up ring

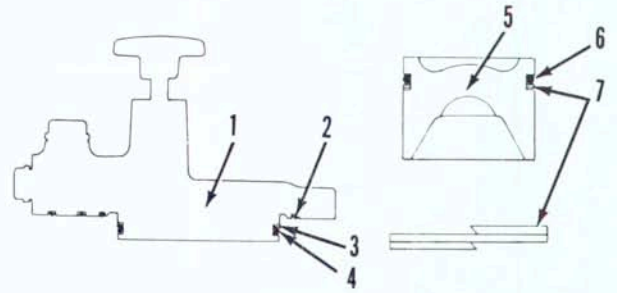

When reassembling rockshaft and components, be sure to match alignment marks as shown in Fig. 173. Make certain back-up rings and "O" rings are in-

stalled correctly on piston and cylinder head as shown in Fig. 175. Tighten cylinder head cap screws to a torque of 80-90 N·m (60-65 ft.-lbs.).

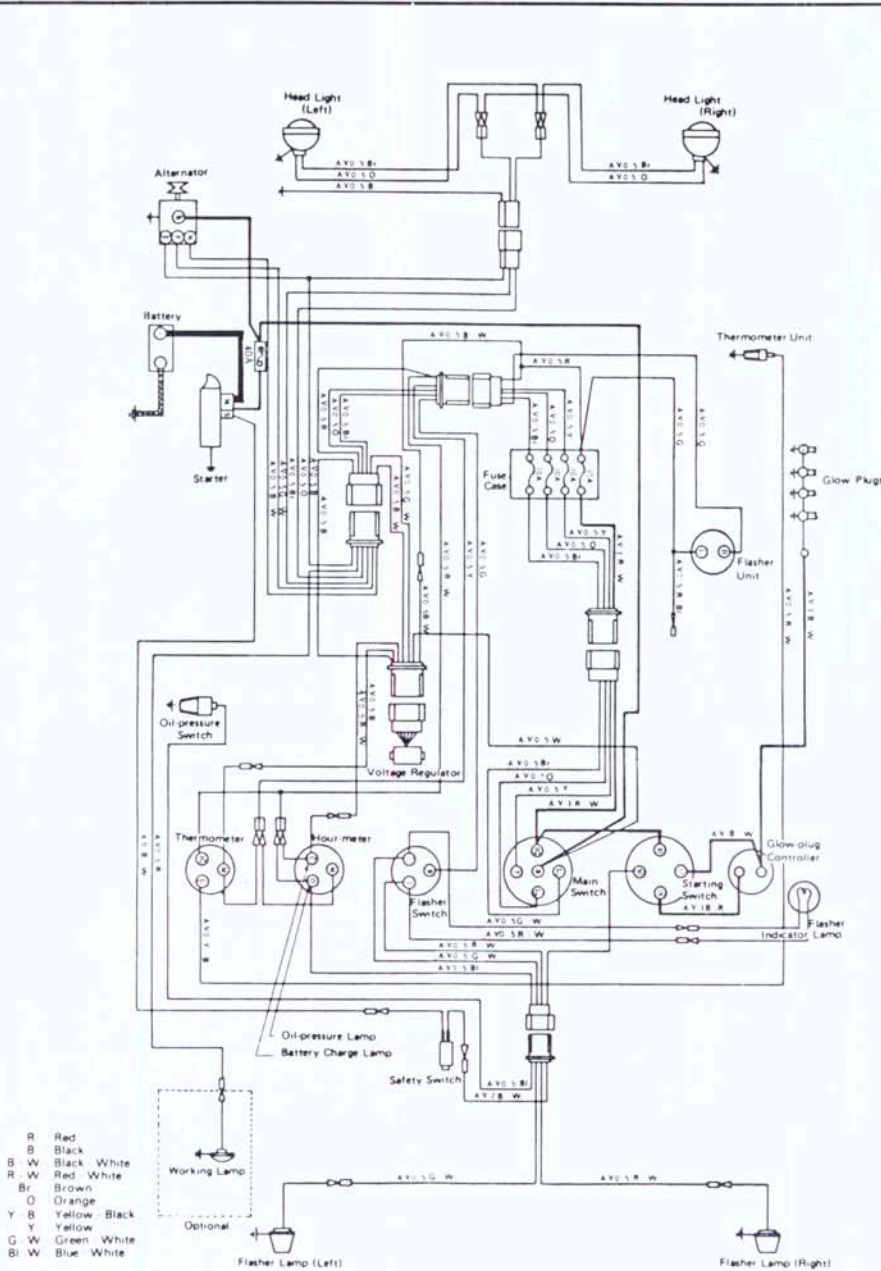

- R Red
- B Black
- B W Black White
- R W Red White
- Br Brown
- O Orange
- Y B Yellow Black
- Y Yellow
- G W Green White
- Bl W Blue White

Fig. 176—Wiring diagram for Model L285.

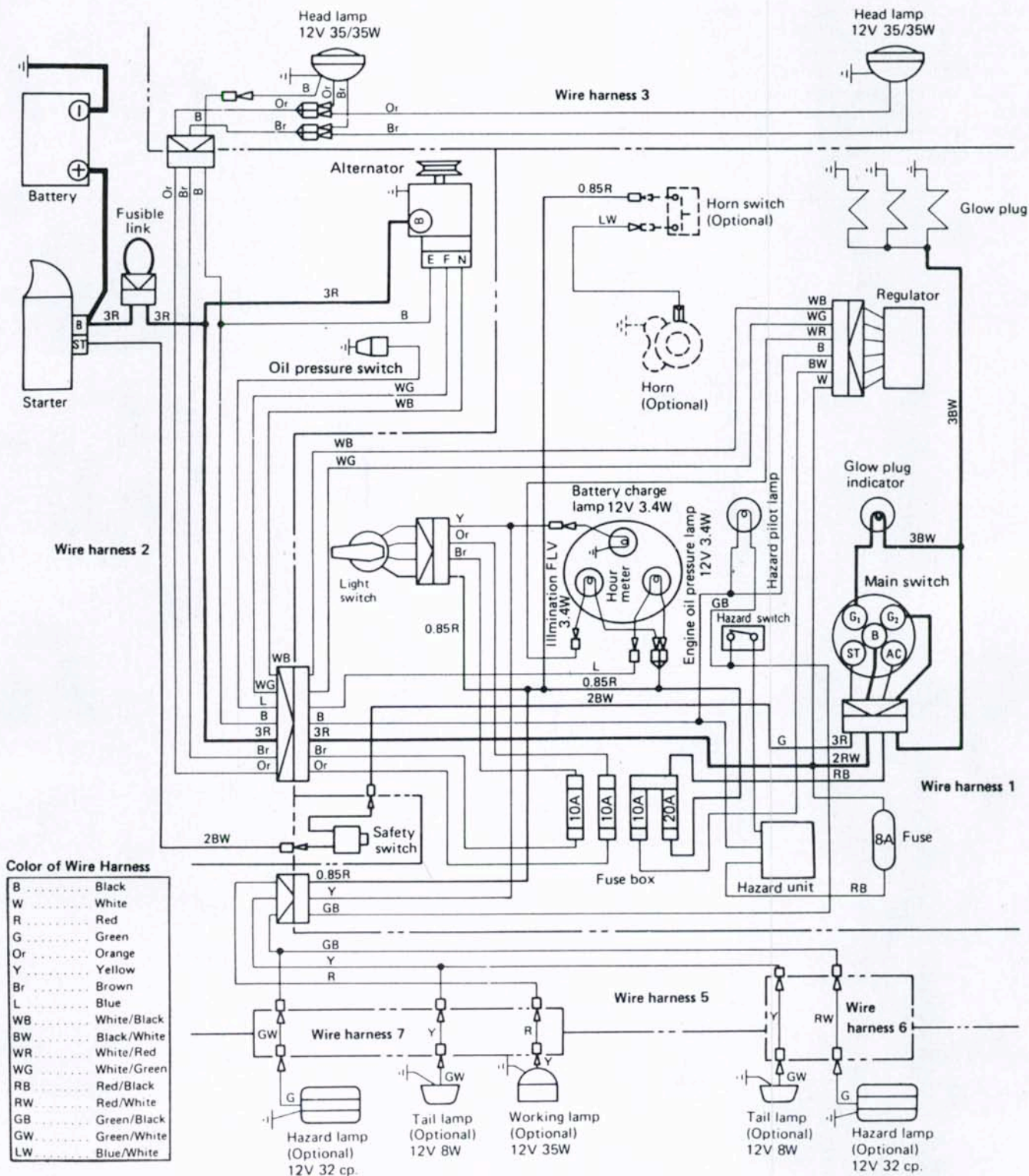

Fig. 177—Wiring diagram for Models L235 and L275.

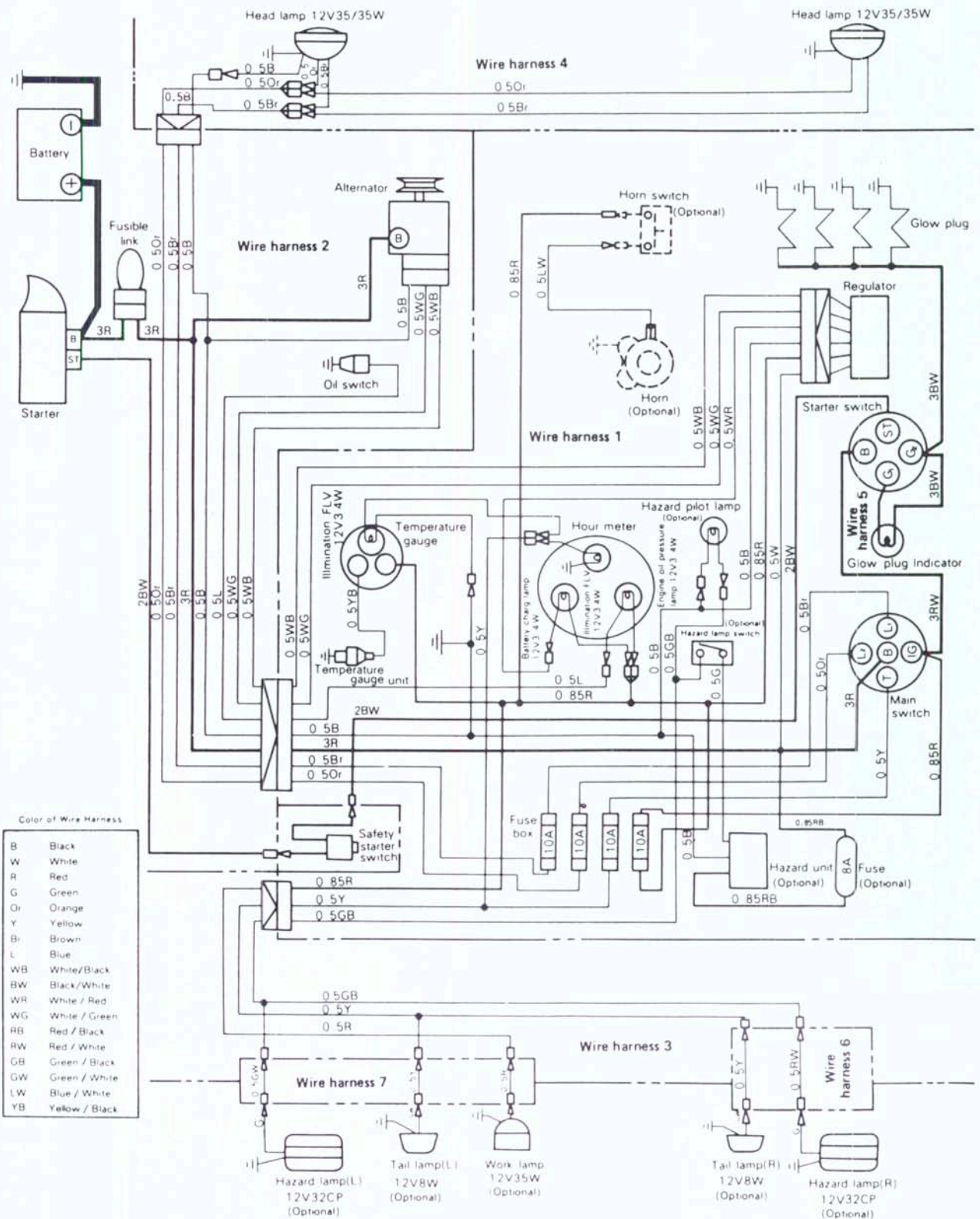

Fig. 178—Wiring diagram for Model L355.

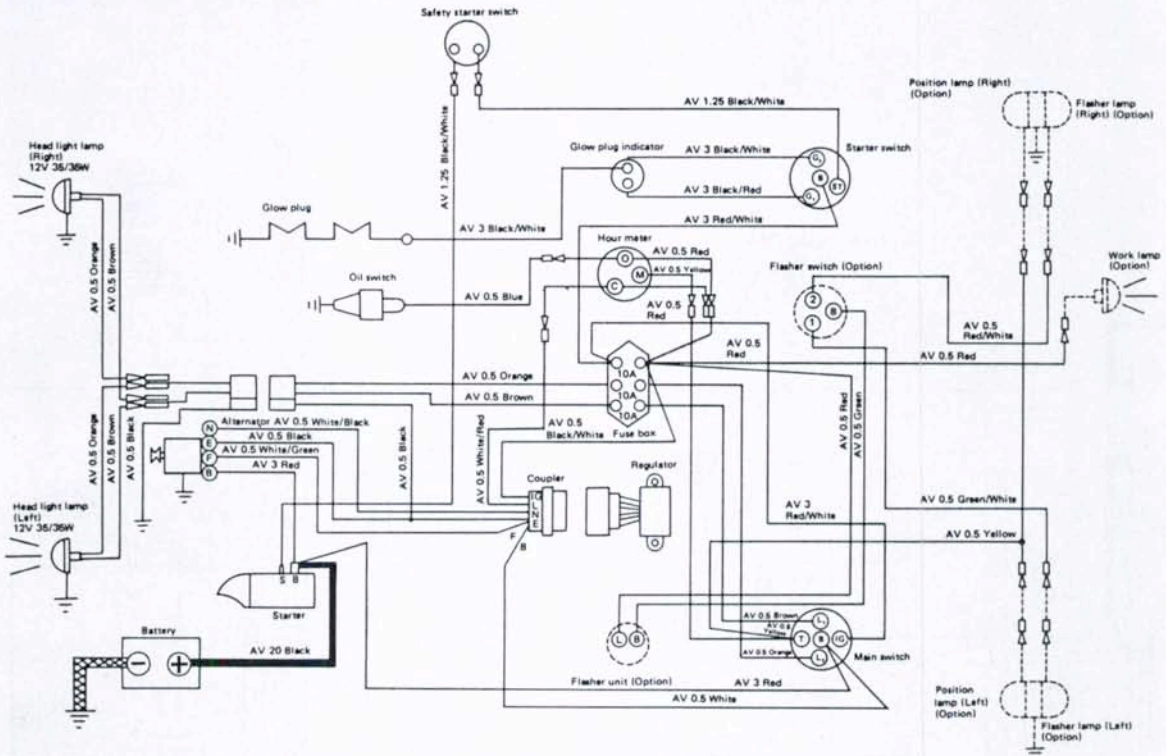

Fig. 179—Wiring diagram for Models L185 and L245.

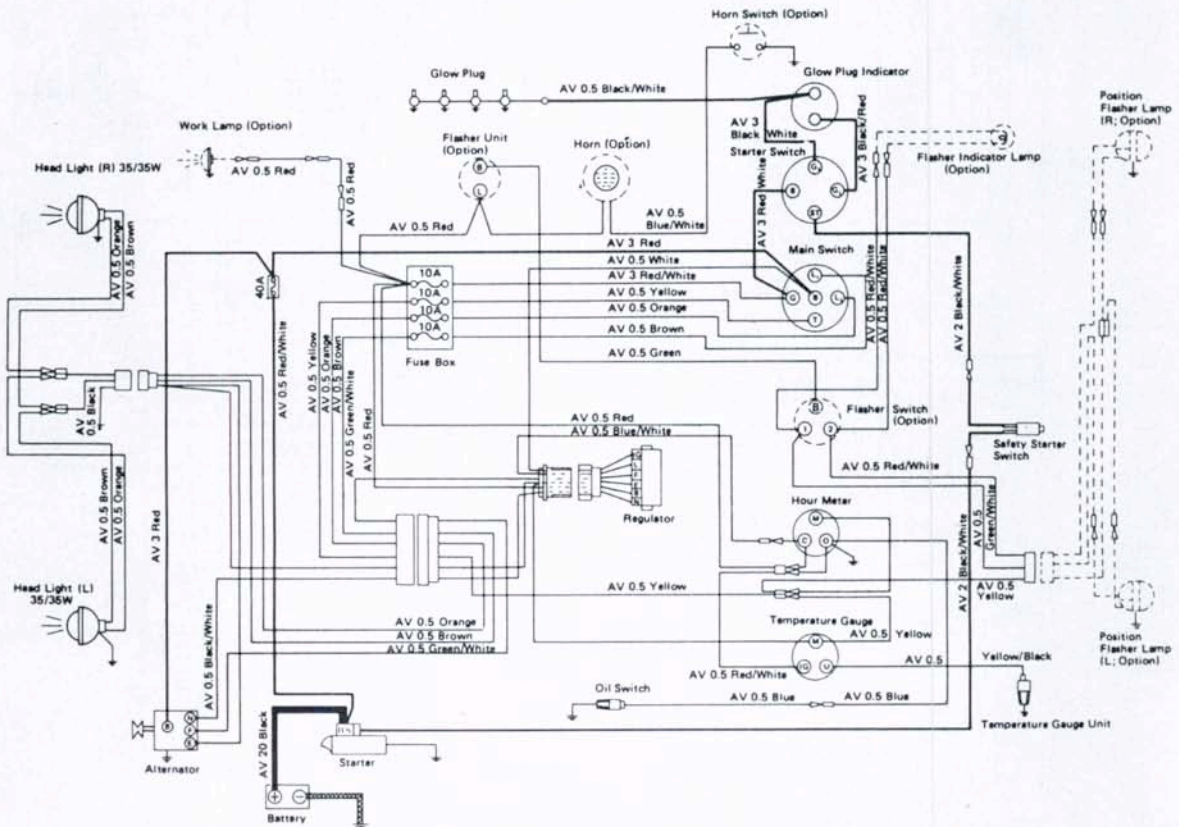

Fig. 180—Wiring diagram for Models L295, L305 and L345.